

Absolute maximum ratings

($T_a=25^\circ\text{C}$)

Symbol	Ratings	Unit
V_{CBO}	-60	V
V_{CEO}	-60	V
V_{EBO}	-6	V
I_C	-4	A
I_B	-1	A
P_T	4 ($T_a=25^\circ\text{C}$)	W
	20 ($T_c=25^\circ\text{C}$)	
T_j	150	$^\circ\text{C}$
T_{stg}	-40 to +150	$^\circ\text{C}$

Electrical characteristics

($T_a=25^\circ\text{C}$)

Symbol	Specification			Unit	Conditions
	min	typ	max		
I_{CBO}			-10	μA	$V_{CB}=-60\text{V}$
I_{EBO}			-10	mA	$V_{EB}=-6\text{V}$
V_{CEO}	-60			V	$I_C=-10\text{mA}$
h_{FE}	2000				$V_{CE}=-4\text{V}$, $I_C=-3\text{A}$
$V_{CE(sat)}$			-1.5	V	$I_C=-3\text{A}$, $I_B=-6\text{mA}$

Equivalent circuit diagram

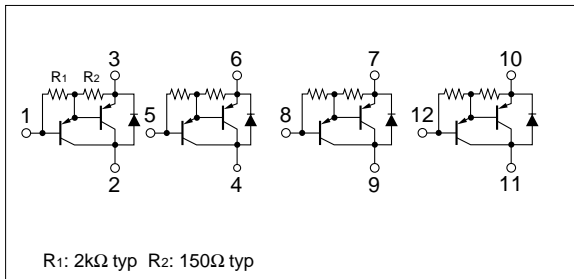

I_C - V_{CE} Characteristics (Typical)

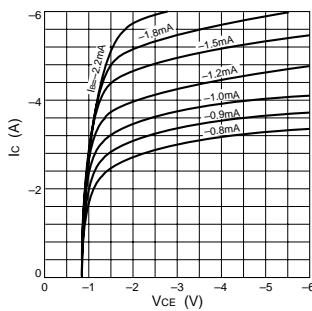

h_{FE} - I_C Characteristics (Typical)

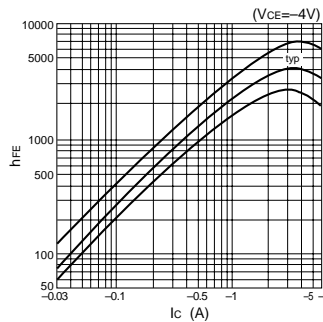

h_{FE} - I_C Temperature Characteristics (Typical)

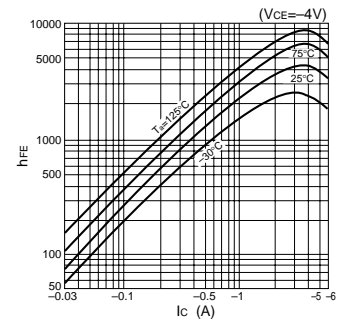

$V_{CE(sat)}$ - I_C Temperature Characteristics (Typical)

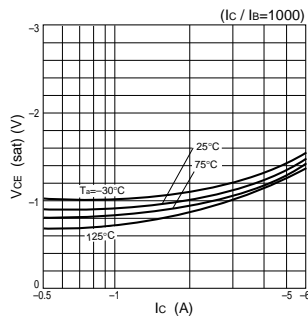

$V_{CE(sat)}$ - I_B Characteristics (Typical)

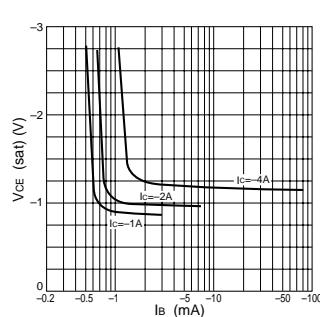

I_C - V_{BE} Temperature Characteristics (Typical)

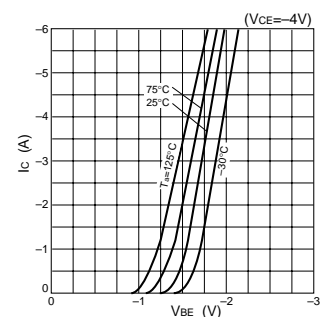

θ_{j-a} -PW Characteristics

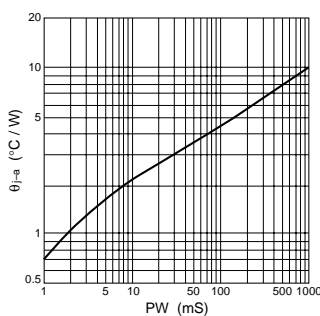

P_T - T_a Characteristics

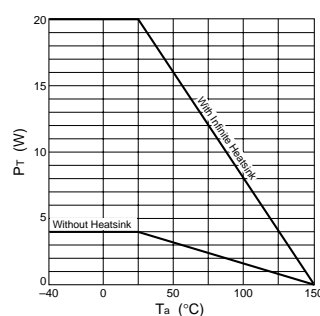

Safe Operating Area (SOA)

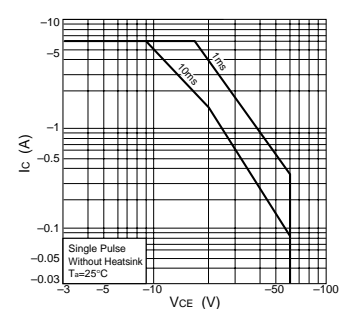

• SIP 8 (STA8Pin)

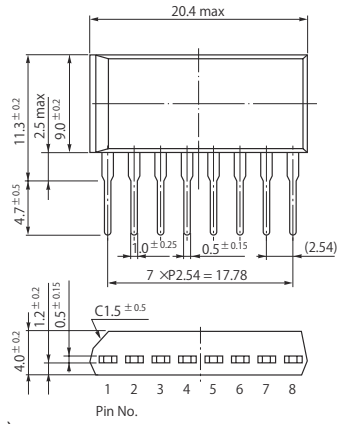

• SIP 10 (STA10Pin)

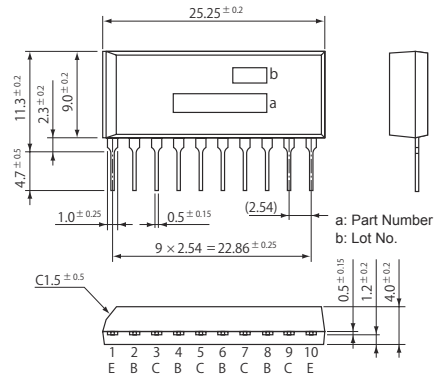

• SIP 12 (SMA12Pin)

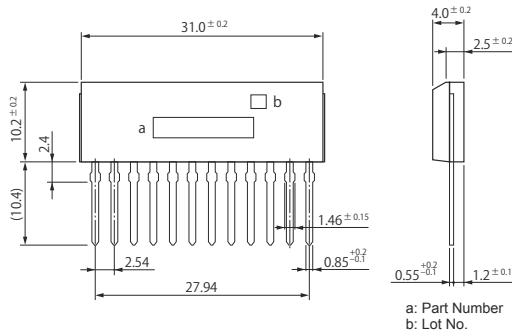

• SIP 15 (SMA15Pin)

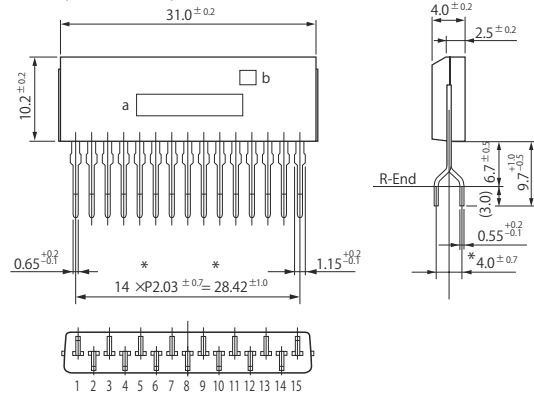

• SIP 12 with Fin (SLA12Pin)

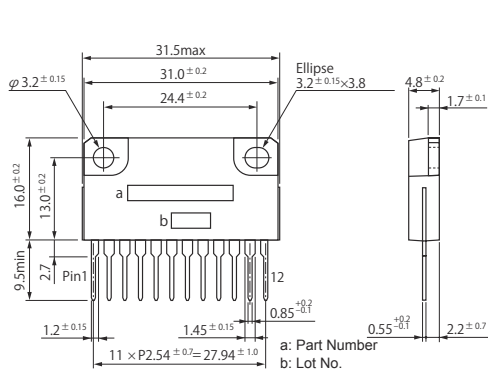

• SIP 15 with Fin (SLA15Pin)

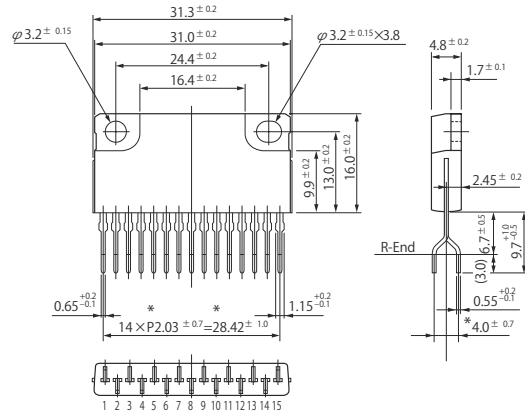

• SIP 21 with Fin (SLA21Pin)

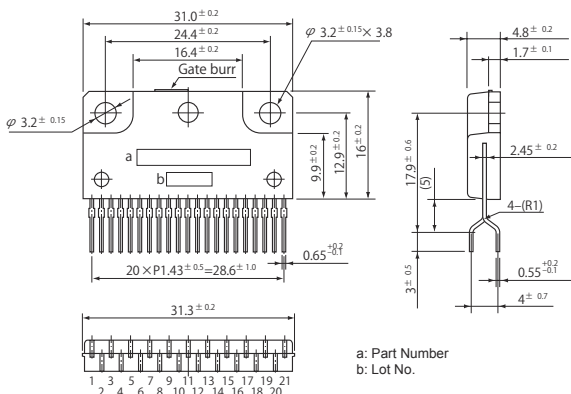

(Unit:mm)