

## LED Drivers for LCD Backlights

# White Backlight LED Drivers for Medium to Large LCD Panels (Switching Regulator Type)



BD6066GU, BD6066EKN

No.11040EBT26

## ●Description

BD6066GU/BD6066EKN are white LED driver ICs with PWM step-up DC/DC converter that can boost max 40.5V and current driver that can drive max 30mA. The wide brightness can be adjusted to control by external PWM pulse on power control terminal. And, with extended resolution current driver, a few errors between the lines of the current driver, it is suitable for decreasing the lacking in brightness of the display. BD6066GU, CSP package type, is suited for saving space. BD6066EKN, HQFN package type, is suited for mounting on the flexible board.

## ●Features

- 1) High efficiency PWM step-up DC/DC converter (fsw=1MHz)
- 2) Extended resolution current driver 4ch
- 3) Driving \* 12 series × 4parallel =48 white LEDs (\* white LED Vf=3.2Vmax)
- 4) Wide input voltage range (2.7V ~ 22V)
- 5) Rich safety functions
  - Over-voltage protection (OVP)
  - Over current limit
  - External SBD open detect
  - Thermal shutdown (175 °C)
- 6) CSP small & thin package
 

VCSP85H2	2.6 × 2.6 × 0.85mm
HQFN28V	5.2 × 5.2 × 0.95mm

## ●Applications

Notebook PC, portable DVD player, car navigation systems

## ● Absolute maximum ratings (Ta=25 °C)

Parameter	Symbol	Limits	Unit	Condition
Maximum applied voltage 1	VMAX1	7	V	TEST,ISET,VREG,SENSP, SENSN, SW, EN1, EN2, PWM
Maximum applied voltage 2	VMAX2	15.5	V	LED1, LED2, LED3, LED4
Maximum applied voltage 3	VMAX3	30.5	V	VBAT
Maximum applied voltage 4	VMAX4	50.5	V	VDET
Power dissipation 1 (BD6066GU)	Pd1	1100 <sup>*1</sup>	mW	
Power dissipation 2 (BD6066EKN)	Pd2	560 <sup>*2</sup>	mW	
Power dissipation 3 (BD6066EKN)	Pd3	880 <sup>*3</sup>	mW	
Power dissipation 4 (BD6066EKN)	Pd4	2650 <sup>*4</sup>	mW	
Operating temperature range	Topr	-30 ~ +85	°C	
Storage temperature range	Tstg	-55 ~ +150	°C	

(\*1) The measurement value which was mounted on the PCB by ROHM. When it's used by more than Ta=25 °C, it's reduced by 8.8mW/ °C.

(\*2) Reduced 4.5mW/ °C With Ta>25 °C when not mounted on a heat radiation Board.

(\*3) 70mm × 70mm × 1.6mm glass epoxy Board which has 1 layers (60mm × 60mm). When it's used by more than Ta=25 °C, it's reduced by 7.0mW/ °C.

(\*4) 70mm × 70mm × 1.6mm glass epoxy Board which has 2 layers (60mm × 60mm). When it's used by more than Ta=25 °C, it's reduced by 21.2mW/ °C.

## ● Recommended operating range (Ta=-30 °C ~ +85 °C)

Parameter	Symbol	Limits			Unit	Condition
		Min.	Typ.	Max.		
Power supply voltage	BD6066GU	VBAT	2.7	12.0	22.0	V
	BD6066EKN					

## ● Electrical characteristic (Unless otherwise specified, VBAT=12V, Ta = +25 °C)

Parameter	Symbol	Limits			Unit	Condition
		Min.	Typ.	Max.		
<b>[EN Terminal]</b>						
EN threshold voltage (Low)	VthL	0	-	0.2	V	
EN threshold voltage (High) 1	VthH1	1.4	-	5.0	V	VBAT > 5.0V
EN threshold voltage (High) 2	VthH2	1.4	-	VBAT	V	VBAT < 5.0V
EN terminal input current	Iin	-	8.3	14.0	μA	EN=2.5V
EN terminal output current	Iout	-2.0	-0.1	-	μA	EN=0V
<b>[PWM Terminal]</b>						
Low Input Voltage range	PWML	0	-	0.2	V	
High Input Voltage range1	PWMH1	1.4	-	5.0	V	VBAT > 5.0V
High Input Voltage range2	PWMH2	1.4	-	VBAT	V	VBAT < 5.0V
PWM pull down resistor	PWMR	300	500	700	kΩ	
<b>[Regulator]</b>						
VREG Voltage	VREG	4.0	5.0	6.0	V	
Under Voltage Lock Out	UVLO	2.05	2.35	2.65	V	
<b>[Switching Regulator]</b>						
Input voltage range	Vin	3.1	12.0	22.0	V	*1
Quiescent Current 1	Iq1	-	0.6	3.4	μA	EN=0V, VBAT=12V
Quiescent Current 2	Iq2	-	4.6	10	μA	EN=0V, VBAT=22V
Current Consumption	Idd	-	3.4	5.1	mA	EN=3.6V, VDET=0V, ISET=24kΩ
LED Control voltage	VLED	0.4	0.5	0.6	V	
Over Current Limit voltage	Ocp	70	100	130	mV	*2
SBD Open Protect	Sop	-	0.2	1.4	V	
Switching frequency	fSW	0.8	1.0	1.2	MHz	
Duty cycle limit	Duty	92.5	95.0	99.0	%	LED1=LED2=LED3=LED4=0V
Over Voltage Limit	Ovl	40.5	42.0	43.5	V	LED1=LED2=LED3=LED4=0V
Start up time	Ts	-	0.5	1.0	ms	Output voltage=24V
<b>[Current driver]</b>						
LED maximum current	ILMAX	-	-	30	mA	
LED current accuracy	ILACCU	-	-	±5	%	ILED=20mA
LED current matching	ILMAT	-	-	±3	%	- Each LED current / Average (LED1,2,3,4) - ILED=20mA
ISET voltage	Iset	0.5	0.6	0.7	V	
LED current limiter	ILOCP	35	60	90	mA	
LED Terminal Over Voltage Protect	LEDOVP	12.5	13.5	14.5	V	

\*1 Electrical characteristics are guaranteed from 3.1V to 22V and operating is guaranteed from 2.7V to 3.1V.

\*2 This parameter is tested with dc measurement.

●Reference data

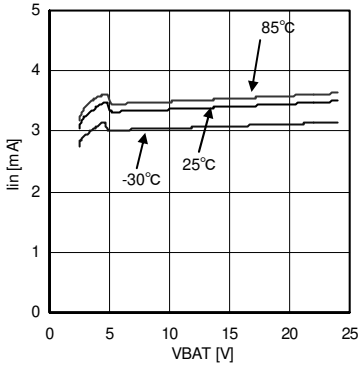

Fig.1  
Current Consumption - power source voltage

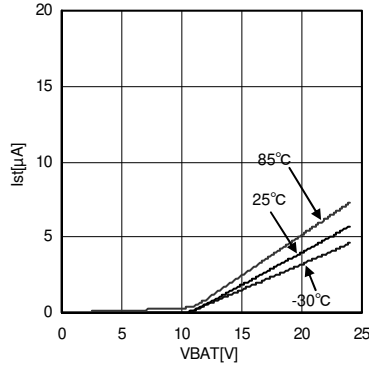

Fig.2  
Quiescent current - power source voltage

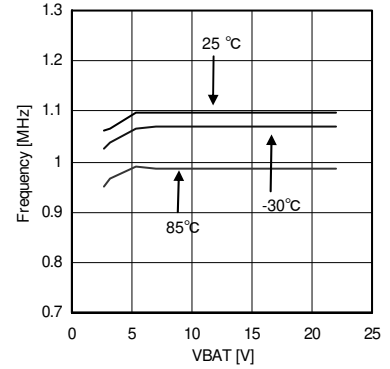

Fig.3  
Oscillation frequency - power source voltage

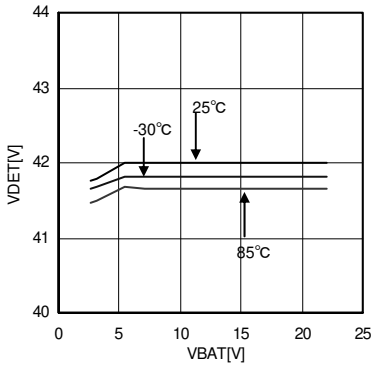

Fig.4  
Over Voltage Limit - power source voltage

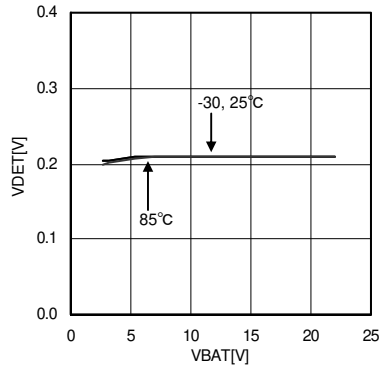

Fig.5  
SBD Open Protect Limit - power source voltage

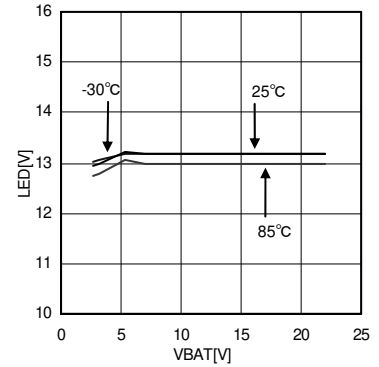

Fig.6  
LED terminal Over Voltage Protect vs power source voltage

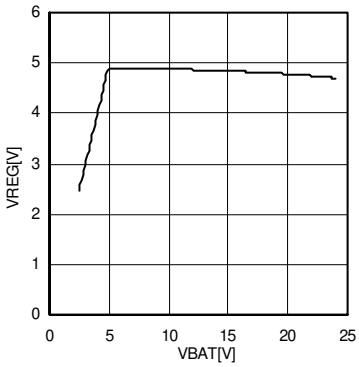

Fig.7  
VREG - power source voltage

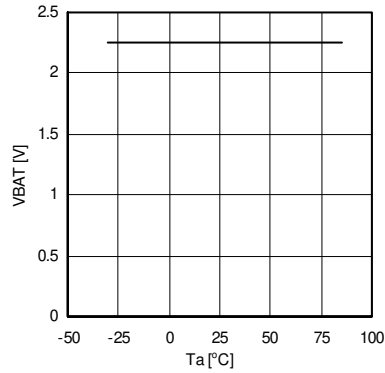

Fig.8  
UVLO - Temperature

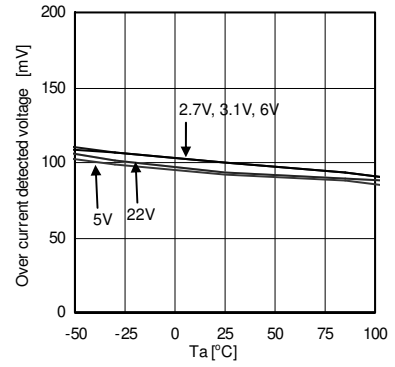

Fig.9  
Over Current Limit Voltage - Temperature

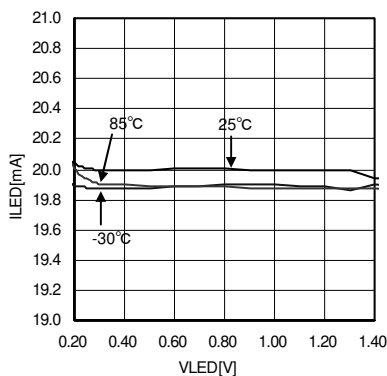

Fig.10  
LED current - LED terminal voltage  
(Expansion)

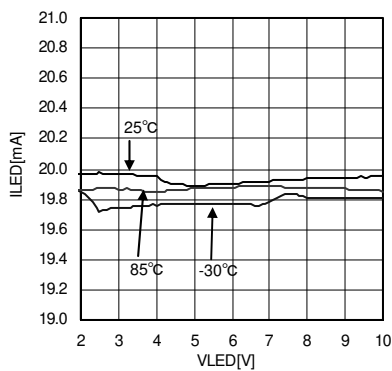

Fig.11  
LED current - LED terminal voltage

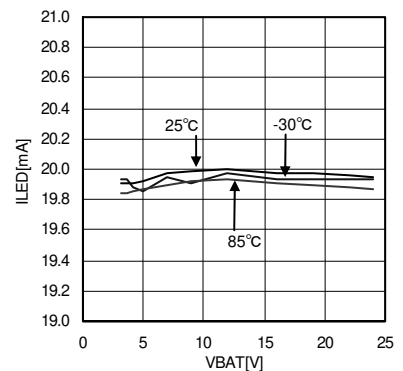
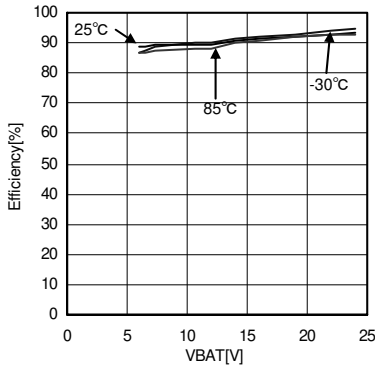
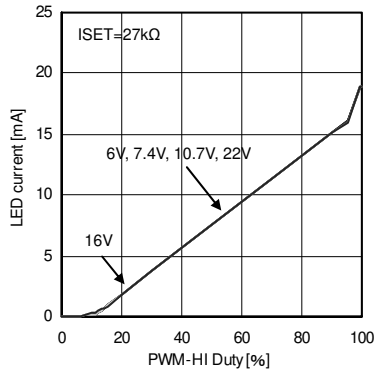

Fig.12  
LED current - power source voltage



**Fig.13**  
Efficiency - source voltage



**Fig.14**  
LED current - PWM HI Duty  
PWM = 200Hz

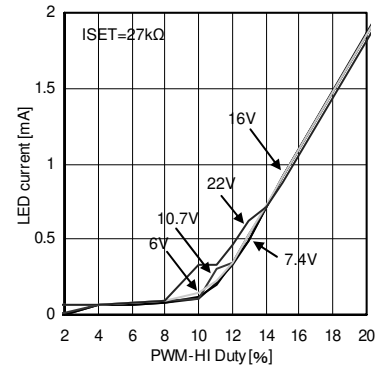

**Fig.15**  
LED current - PWM HI Duty (Expansion)  
PWM = 200Hz

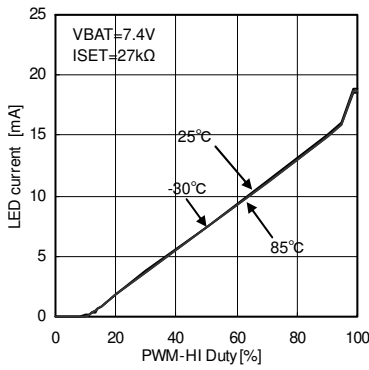

**Fig.16**  
LED current - PWM HI Duty  
PWM = 200Hz

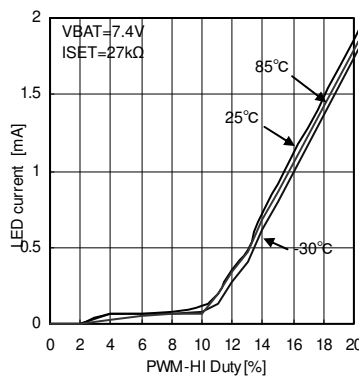

**Fig.17**  
LED current - PWM HI Duty (Expansion)  
PWM = 200Hz

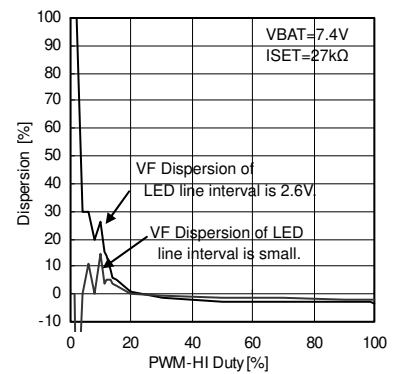

**Fig.18**  
LED current matching - PWM HI Duty  
PWM = 200Hz

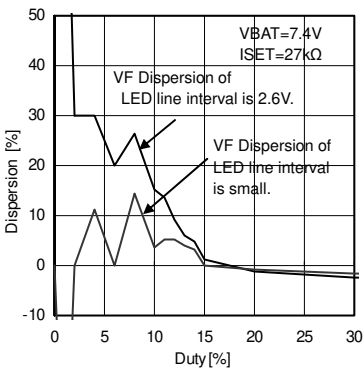

**Fig.19**  
LED current matching - PWM HI Duty  
(Expansion) PWM = 200Hz

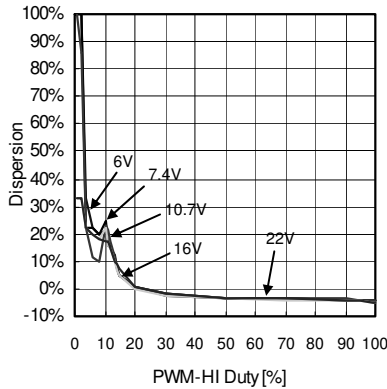

**Fig.20**  
LED current matching - PWM HI Duty  
VF Dispersion of LED line interval is 2.6V.  
PWM = 200Hz

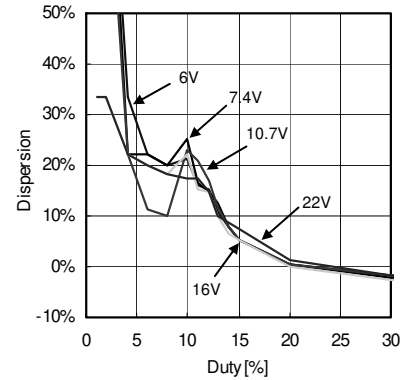

**Fig.21**  
LED current matching - PWM HI Duty (Expansion)  
VF Dispersion of LED line interval is 2.6V.  
PWM = 200Hz

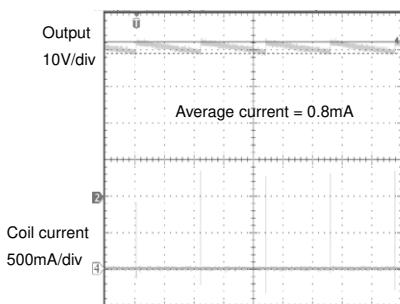

**Fig.22**  
LED Open Voltage

●Block diagram, I/O equivalent circuit diagram

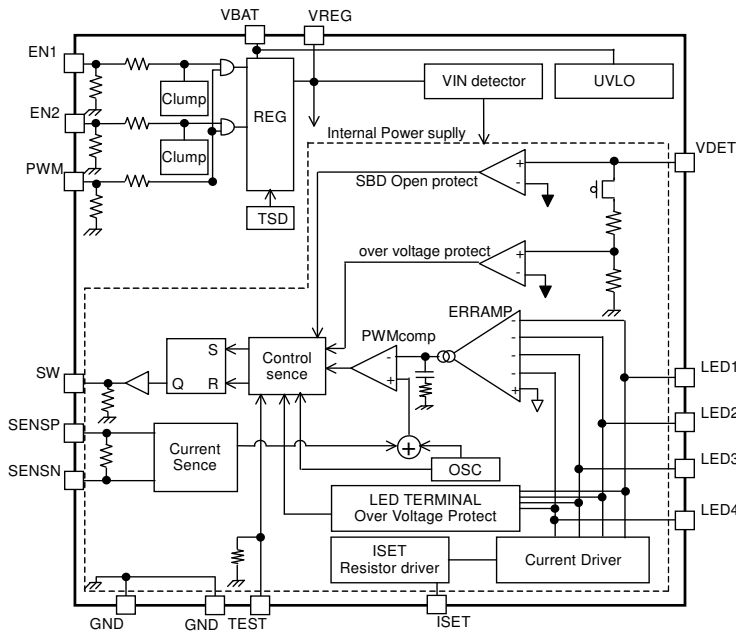

Fig.23 Block diagram

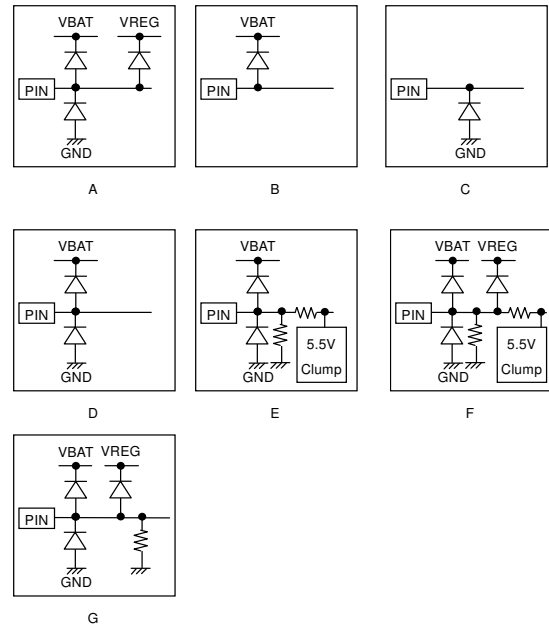

Fig.24 I/O equivalent circuit diagram

●Pin assignment table

PIN Name	In/Out	PIN number		Function	Terminal equivalent circuit diagram
		BD6066GU	BD6066EKN		
SENSN	In	A1	1	- Side Current sense terminal	A
GND	-	A2	2	GND	B
VDET	In	C3	3	Detect input for SBD open and OVP	C
N.C.	-	-	4	No connect pin	-
N.C.	-	-	5	No connect pin	-
ISET	In	A3	6	Resistor connection for LED current setting	A
TEST	In	A4	7	TEST input (Pull down 100kΩ to GND)	G
N.C.	-	-	8	No connect pin	-
LED4	In	A5	9	Current sink for LED4	C
LED3	In	B5	10	Current sink for LED3	C
N.C.	-	-	11	No connect pin	-
LED2	In	C5	12	Current sink for LED2	C
LED1	In	D5	13	Current sink for LED1	C
N.C.	-	-	14	No connect pin	-
EN1	In	E5	15	Enable input 1	E
N.C.	-	-	16	No connect pin	-
EN2	In	E3	17	Enable input 2	E
N.C.	-	-	18	No connect pin	-
VBAT	In	E4	19	Battery input	C
VREG	Out	E2	20	Regulator output / Internal power-supply	D
PWM	In	E1	21	PWM input	F
N.C.	-	-	22	No connect pin	-
GND	-	D1	23	GND	B
N.C.	-	-	24	No connect pin	-
VREG	Out	-	25	Regulator output / Internal power-supply	D
SW	Out	C1	26	Switching Tr drive terminal	G
SENSP	In	B1	27	+ Side Current sense terminal	G
GND	-	-	28	GND	B

●Application example

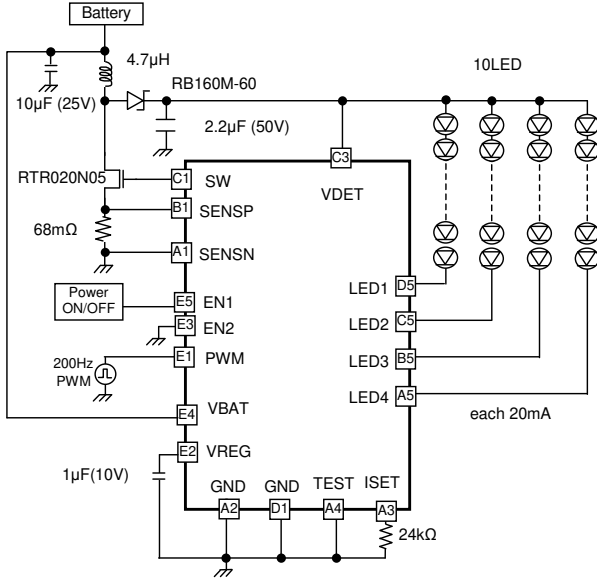

Fig.25 LED current 20mA setting example  
(10 series x 4parallel)

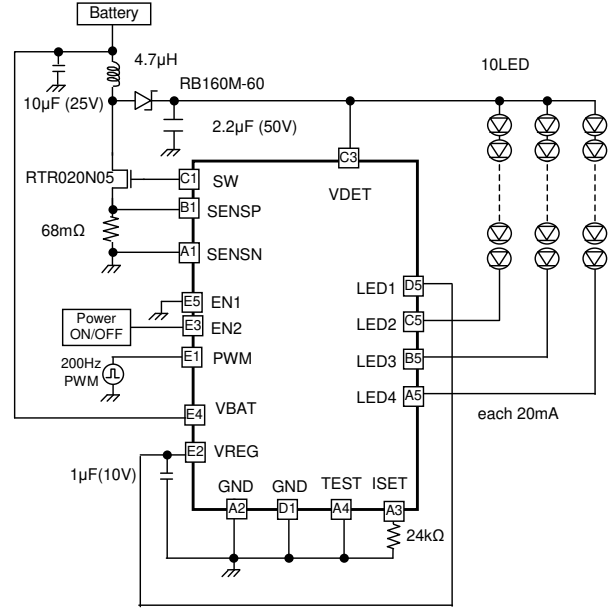

Fig.26 LED current 20mA setting example  
(10 series x 3parallel)

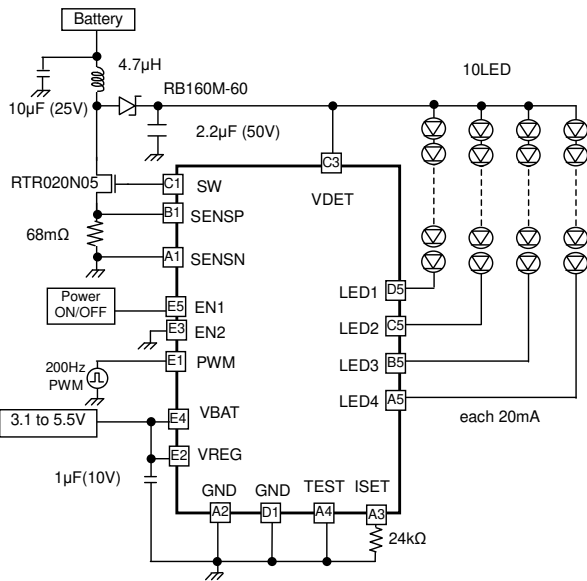

Fig.27 Separated power supply of IC and coil setting example

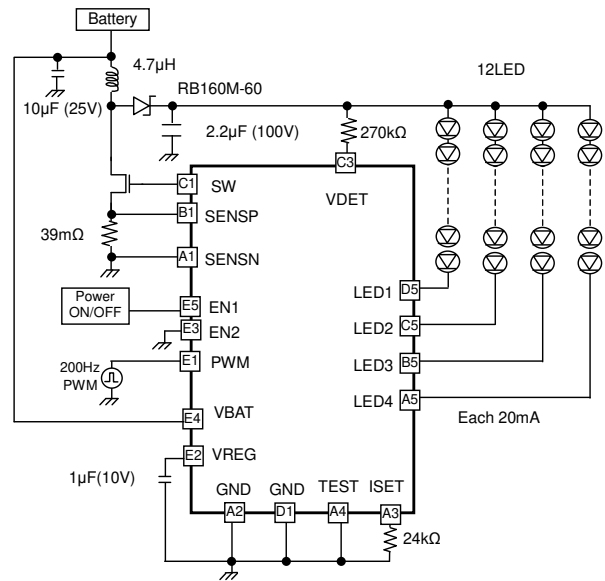

Fig.28 Over voltage 48.1V(typ) by external resistor,  
LED current 20mA setting example  
(12 series (V<sub>F</sub>=3.6Vmax) x 4parallel)

●Terminal processing

- TEST pin = Connect to GND
- N.C. = Nothing specified in particular. Open is recommended.
- VREG = When IC is driving from the outside of 3.1~5.5V, short VBAT and VREG, and put the voltage to VREG
- EN1, 2 = Connect to GND in case of fixing at L level
- LED1, 2 = When each LED driver are not used at EN setting, connect to VREG terminal or the power supply of more than 1V.
- GND = Each GND is connecting inside IC. Connect to GND of all PCB

## ●Description of Functions

### 1) PWM current mode DC/DC converter

While BD6066GU/EKN is power ON, the lowest voltage of LED1, 2, 3, 4 is detected, PWM duty is decided to be 0.5V and output voltage is kept invariably. As for the inputs of the PWM comparator as the feature of the PWM current mode, one is overlapped with error components from the error amplifier, and the other is overlapped with a current sense signal that controls the inductor current into Slope waveform to prevent sub harmonic oscillation. This output controls external Nch Tr via the RS latch. In the period where external Nch Tr gate is ON, energy is accumulated in the external inductor, and in the period where external Nch Tr gate is OFF, energy is transferred to the output capacitor via external SBD. BD6066GU/EKN has many safety functions, and their detection signals stop switching operation at once.

### 2) Soft start and off status

BD6066GU/EKN has soft start function and off status function.

The soft start function and the off status function prevent large coil current.

Rush current at turning on is prevented by the soft start function, and invalid current at turning off is prevented by the off status function.

### 3) External SBD open detect and over voltage protection

BD6066GU/EKN has over boost protection by external SBD open and over voltage protection. This function will stop the switching. Details are as shown below.

#### ▪ External SBD open detect

In the case of external SBD is not connected to IC, the coil or external Tr may be destructed. Therefore, at such an error as VOUT becoming 0.2V or below, the Under Detector shown in the figure works, and turns off the output Tr, and prevents the coil and the IC from being destructed.

And the IC changes from activation into non-activation, and current does not flow to the coil (0mA).

#### ▪ Over voltage protection

At such an error of output open as the output DC/DC and the LED is not connected to IC, the DC/DC will boost too much and the VDET terminal exceed the absolute maximum ratings, and may destruct the IC. Therefore, when VDET becomes sensing voltage or higher, the over voltage limit works, and turns off the output Tr, and the pressure up made stop. At this moment, the IC changes from activation into non-activation, and the output voltage goes down slowly. And, when the output voltage becomes the hysteresis of the over voltage limit or below, the output voltage pressure up to sensing voltage once again and unless the application error is recovered, this operation is repeated.

This protection action is shown in Fig.29.

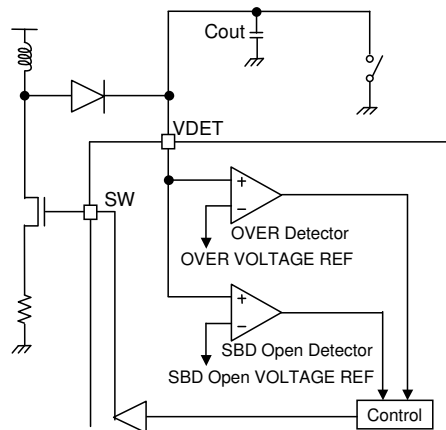

Fig.29 Block diagram of external SBD open detect and over voltage

### 4) Thermal shut down

BD6066GU/EKN has thermal shut down function.

The thermal shut down works at 175°C or higher, and while holding the setting of EN control from the outside, the IC changes from activation into non-activation. And at 175°C or below, the IC gets back to its normal action.

## 5) Over Current Limit

Over current flows the current detection resistor that is connected to switching transistor source and between GND, SENSP pin voltage turns more than detection voltage, over current protection is operating and it is prevented from flowing more than detection current by reducing ON duty of switching Tr without stopping boost.

As over current detector of BD6066GU/EKN is detected peak current, current more than over current setting value does not flow.

And, over current value can decide freely by changing over current detection voltage.

<Derivation sequence of detection resistor>

Detection resistor = Over current detection voltage / Over current setting value

TYP value of over current detection voltage is 100mV, MIN = 70mV and MAX = 130mV and after the current value which was necessary for the normal operation was decided, detection resistor is derived by using MIN value of over current detection value.

For example, detection resistor when necessary current value was set at 1A is given as shown below.

Detection resistor = 70mV / 1A = 70mΩ

MAX current dispersion of this detection resistor value is

MAX current = 130mV / 70mΩ = 1.86A

<The estimate of the current value which need for the normal operation >

As over current detector of BD6066GU/EKN is detected the peak current, it have to estimate peak current to flow to the coil by operating condition.

In case of, Supply voltage of coil = VIN

Reactance value of coil = L

Switching frequency = fsw

MIN=0.8MHz, Typ=1MHz, MAX=1.2MHz

Output voltage = VOUT

Total LED current = IOUT

Average current of coil = Iave

Peak current of coil = Ipeak

Efficiency = eff

(Please set up having margin, it refers to data on p.4.)

ON time of switching transistor = Ton

$$I_{peak} = (VIN / L) \times (1 / fsw) \times (1 - (VIN / VOUT))$$

$$I_{ave} = (VOUT \times IOUT / VIN) / eff$$

$$Ton = (I_{ave} \times (1 - VIN/VOUT) \times (1/fsw) \times (L/VIN) \times 2)^{1/2}$$

Each current is calculated.

As peak current varies according to whether there is the direct current superposed, the next is decided.

$(1 - VIN/VOUT) \times (1/fsw) < Ton \rightarrow$  peak current =  $I_{peak} / 2 + I_{ave}$

$(1 - VIN/VOUT) \times (1/fsw) > Ton \rightarrow$  peak current =  $I_{peak}$

(Example 1)

In case of, VIN=6.5V, L=4.7μH, fsw=1MHz, VOUT=39V, IOUT=80mA, Efficiency=85%

$$I_{peak} = (6.5V / 4.7\mu H) \times (1 / 1MHz) \times (1 - (6.5V / 39V)) = 1.08A$$

$$I_{ave} = (39V \times 80mA / 6.0V) / 85\% = 0.61A$$

$$Ton = (0.61A \times (1 - 6.0V / 39V) \times (1 / 1MHz) \times (4.7\mu H / 6.0V) \times 2)^{1/2} = 0.90\mu s$$

$$(1 - VIN/VOUT) \times (1/fsw) = 0.85\mu s < Ton$$

$$\text{Peak current} = 1.08A/2 + 0.61A = 1.15A$$

(Example 2)

In case of, VIN=12.0V, L=4.7μH, fsw=1MHz, VOUT=39V, IOUT=80mA, Efficiency=85%

$$I_{peak} = (12.0V / 4.7\mu H) \times (1 / 1MHz) \times (1 - (12V / 39V)) = 1.77A$$

$$I_{ave} = (39V \times 80mA / 12.0V) / 85\% = 0.31A$$

$$Ton = (0.31A \times (1 - 12V / 39V) \times (1 / 1MHz) \times (4.7\mu H / 12V) \times 2)^{1/2} = 0.41\mu s$$

$$(1 - VIN/VOUT) \times (1/fsw) = 0.69\mu s > Ton$$

$$\text{Peak current} = 12V/4.7\mu H \times 0.41\mu s = 1.05A$$



●Start control and select constant current driver

BD6066GU/EKN can control the start conditions by EN1, 2 terminal and PWM terminal, and sets 0.2V or below EN1, 2 terminal or sets 0.2 or below PWM terminal and IC can power off by being 0V LED terminal selected EN1, 2. PWM, EN power on at more than 1.4V, constant current can select ON/OFF by the combination of EN as shown below table. When there is unused constant current driver, connect unused LED terminal to VREG terminal or connect to fixed voltage of more than 1V. And, EN1, 2 are changed with PWM=H and it is prohibited to change a constant current driver.

Enable			Constant current driver			
EN1	EN2	PWM	LED1	LED2	LED3	LED4
H	H	H	OFF	OFF	ON	ON
L	H	H	OFF	ON	ON	ON
H	L	H	ON	ON	ON	ON
L	L	H	OFF (As for these setups, power-off IC.)			
H	H	L				
L	H	L				
H	L	L				
L	L	L				

●Off sequence

Off sequence controls power off timing of each block, LED terminal may not exceed the pressure.

After EN or PWM terminal set H→L, it continues electric current by the current value decided with ISET terminal until all the LED terminals selected with EN are less than 40mV and output voltage reduces. On that occasion, the DC/DC power-off is given and it doesn't have a charge to the output capacitor. After that, LED driver is turned off, built-in REG is turned off, and power-off is completed. If the VF tolerance of the LED is large, it doesn't need to examine VF not to exceed pressure of the LED terminal by this sequence.

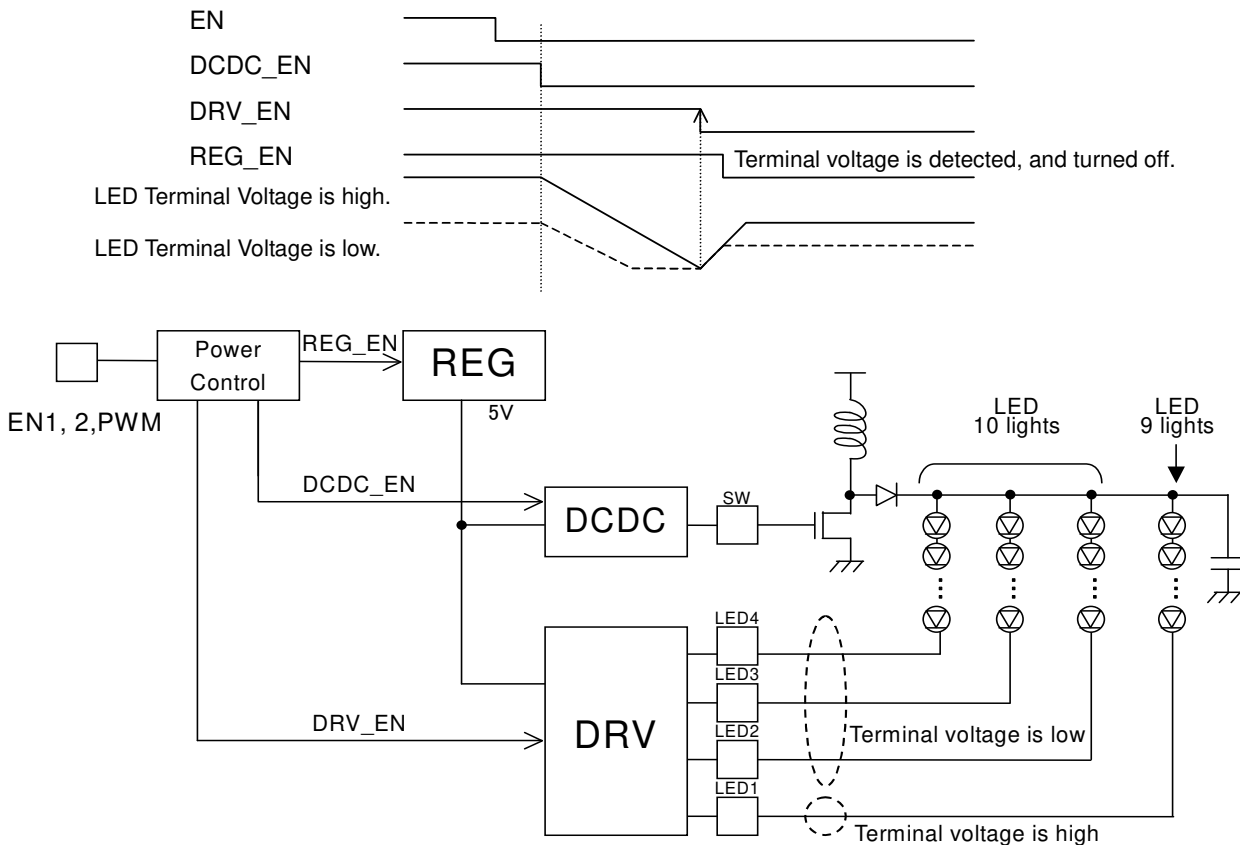

Fig.30 Block diagram of off sequence

●Setting of LED current and current range

LED current can set up resistance value (RISET) connecting to ISET, LED current setting range is 4mA~30mA.

Setting of LED current is given as shown below.  
LED current = 20mA × ( 24kΩ / RISET)

The current in the standard application is as shown below.  
RISET=24kΩ, LED current=20mA

ISET setting example

RISET	LED current
24.0 kΩ (E24)	20.0mA
25.5 kΩ (E96)	18.8mA
27.0 kΩ (E12)	17.8mA
28.0 kΩ (E96)	17.1mA
30.0 kΩ (E24)	16.0mA
33.0 kΩ (E6)	14.5mA

●Brightness control

PWM brightness adjustment is made by inputting PWM pulse to PWM pin. The electric current select setting with ISET in the Hi section, and the Lo section turns off the electric current. Lo. The average current increases in proportion with the duty cycle of PWM signal. By this method, IC can power off at the OFF time, the IC and LED both consume no currents, thus providing a high-efficiency operation. The recommended PWM frequency is 100Hz ~ 300Hz.

<ON time limit>

On time is necessary more than 750µs (at the time of 200Hz, 15%) to require the start up-time of 750µs.

< OFF time limit >

OFF time is approximated by the following parameter.

- External output capacitor : Cvout
- LED current setting : ILED (worst = +5%)
- LED sequence number : NPLED
- LED series number : NSLED
- VF tolerance of LED terminal : ΔVF
- Reaction time of internal circuit : 10µs (worst = 15µs)

Necessary time for OFF (typ) = Cvout × ((ΔVF × NSLED) + 0.5V)/(ILED × NPLED)+10µs

(example)

Necessary time for OFF (typ) = 2µF × ((0.2V × 10 lights) + 0.5V)/(20mA × 4)+10µs = 72.5µs  
<PWM=200Hz, duty1.5% equivalent>

Please use worst value of each parameter when you calculate the worst time.

(example)

Necessary time for OFF (worst) = (2µF × 1.3) × ((0.26V × 10 lights) + 0.7V)/((20mA × 1.05) × 4)+15µs = 117µs  
<PWM=200Hz, duty2.3% equivalent >

And please don't use ON time under 750µs or under OFF time calculated in the above of current setting for the brightness control, because power-on/off has very influential.

●Noise of ceramic capacitor by PWM brightness control

In order to use a ceramic capacitor as the output capacitor, noise of capacitor occurs by the kind of the circuit board and mounted method, the mounting place.

As for the noise cause, the resonant of ceramic capacitor and the board give cause by output voltage fluctuation. Measures of this trouble are shown.

(1) Ceramic capacitor is changed to tantalum capacitor.

By changing to tantalum capacitor, noise is stopped because of changing ceramic capacitor itself bringing about the noise. But, as the output ripple increases by ESR that is characteristic of the tantalum, it needs to select tantalum with low ESR. Also, it recommends connecting parallel capacitor for the noise measure of 0.1µF. Recommended capacitor is shown next page.

(2) Ceramic capacitor is floated from the top of the circuit board.

Reducing the contact surface of the ceramic capacitor and the circuit board can reduce the noise. Capacitor that can float a capacitor from the circuit board are as shown below. This capacitor is connected the metal cap both electrodes of the capacitor, so It can have the effect which be floated because the metal cap is connected to the circuit board. Recommended capacitor is shown next page.

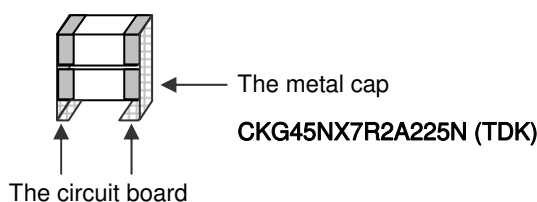

Fig.31 The metal cap capacitor

### ● Selection of external parts

Recommended external parts are as shown below.

When to use other parts than these, select the following equivalent parts.

#### Coil

Value	Manufacturer	Product number	Size			DC current (mA)	DCR (Ω)	Use power voltage range
			Vertical	Horizontal	Height			
4.7μH	TOKO	B1015AS-4R7N	8.4	8.3	4.0	3300	0.038	2.7 ~ 22V
4.7μH	TAIYO YUDEN	NR4012T4R7M	4.0	4.0	1.2	960	0.14	2.7 ~ 22V
4.7μH	TAIYO YUDEN	NR4018T4R7M	4.0	4.0	1.8	1200	0.11	2.7 ~ 22V
6.8μH	TAIYO YUDEN	NR4012T6R8M	4.0	4.0	1.2	840	0.18	7.0 ~ 22V

#### Capacitor

Value	Pressure	Manufacturer	Product number	Size			Temperature range
				Vertical	Horizontal	Height	
<b>[ Power supply capacitor ]</b>							
10μF	25V	MURATA	GRM31CB31E106KA75	3.2	1.6	1.6	-25deg ~ +85deg
<b>[ Smoothing capacitor for built-in regulator ]</b>							
1μF	10V	MURATA	GRM188B10J105KA01	1.6	0.8	0.8	-25deg ~ +85deg
<b>[ Output capacitor ]</b>							
1μF	50V	MURATA	GRM31MB31H105KA87	3.2	1.6	1.15	-25deg ~ +85deg
2.2μF	50V	MURATA	GRM31CB31H225KA87	3.2	1.6	1.6	-25deg ~ +85deg
<b>[ Output capacitor ] Noise measure 1 of ceramic capacitor (tantalum capacitor +0.1μF)</b>							
0.1μF	50V	MURATA	GRM188B31H104KA92	1.6	0.8	0.8	-25deg ~ +85deg
1.0μF	50V	KYOCERA	TAJW105M050	6.0	3.2	1.5	-55deg ~ +125deg
2.2μF	50V	KYOCERA	TAJC225M050	6.0	3.2	2.6	-55deg ~ +125deg
<b>[ Output capacitor ] Noise measure 2 of ceramic capacitor (capacitor with the metal cap)</b>							
2.2μF	100V	TDK	CKG45NX7R2A225N	5.5	4.0	5.5	-55deg ~ +125deg

#### Resistor

Value	Tolerance	Manufacturer	Product number	Size		
				Vertical	Horizontal	Height
<b>[ Resistor for LED current decision &lt;ISET pin&gt; ]</b>						
24kΩ	±0.5%	ROHM	MCR006YZPD243	0.6	0.3	0.23
<b>[ Resistor for over current decision &lt;SENSP pin&gt; ]</b>						
47mΩ	±1%	ROHM	MCR10EZHFRLR047	2.0	1.25	0.55

#### SBD

Pressure	Manufacturer	Product number	Size		
			Vertical	Horizontal	Height
60V	ROHM	RB160M-60	3.5	1.6	0.8

#### MOS FET Nch

Pressure	Manufacturer	Product number	Size			Current ability	Driving voltage
			Vertical	Horizontal	Height		
45V	ROHM	RTR020N05	3.5	1.6	0.8	2A	2.5V
60V	ROHM	2SK2503	9.5	6.5	2.3	5A	4.0V
60V	FAIR CHILD	NDT3055L	6.5	7.0	1.8	4A	2.0V

The coil is the part that is most influential to efficiency. Select the coil whose direct current resistor (DCR) and current - inductance characteristic is excellent. BD6066GU/EKN are designed for the inductance value of 4.7μH or 6.8μH. Do not use other inductance value. Select a capacitor of ceramic type with excellent frequency and temperature characteristics.

Further, select Capacitor to be used with small direct current resistance, and pay sufficient attention to the PCB layout shown in the next page.

### ●PCB Layout

In order to make the most of the performance of this IC, its PCB layout is very important. Characteristics such as efficiency and ripple and the likes change greatly with layout patterns, which please note carefully.

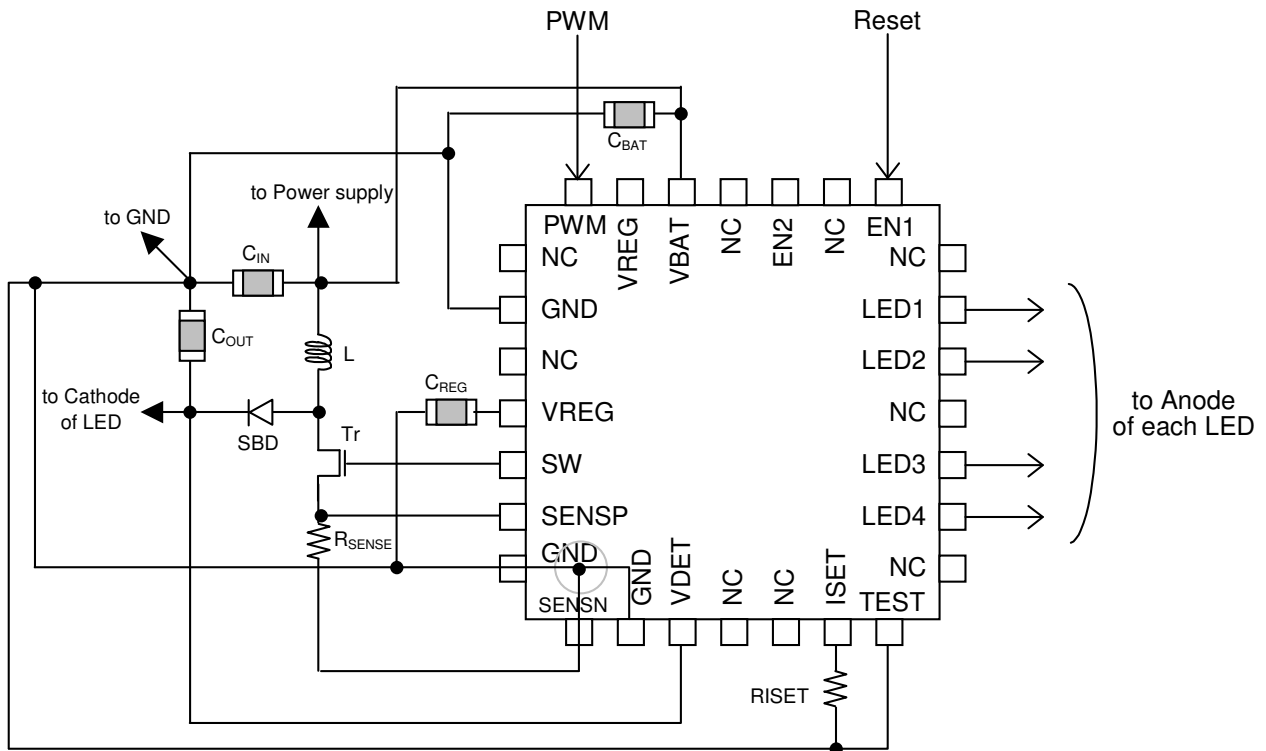

Fig.32 PCB Layout

Connect the input bypass capacitor  $C_{IN}$  ( $10\mu\text{F}$ ) nearest to coil  $L$ , as shown in the upper diagram.

Wire the power supply line by the low resistance from  $C_{IN}$  to  $V_{BAT}$  pin.

And, when it can't be wired by the low resistance, connect the input capacitor  $C_{BAT}$  ( $1\mu\text{F}$ ) nearest to between  $V_{BAT}$  and  $GND$  pin, as shown in the upper diagram. Thereby, the input voltage ripple of the IC can be reduced.

Connect smoothing capacitor  $C_{REG}$  of the regulator nearest to between  $V_{REG}$  and  $GND$  pin, as shown in the upper diagram.

Connect schottky barrier diode  $SBD$  of the regulator nearest to between coil  $L$  and switching transistor  $Tr$ .

And connect output capacitor  $C_{OUT}$  nearest to between  $C_{IN}$  and  $GND$  pin. Thereby, the output voltage ripple of the IC can be reduced.

Connect switching transistor  $Tr$  nearest to  $SW$  pin. Wire coil  $L$  and switching transistor  $Tr$ , current sensing resistor  $R_{SENSE}$  by the low resistance. Wiring to the  $SENSP$  pin isn't  $Tr$  side, but connect it from  $R_{SENSE}$  side.

Over current value may become low when wiring from  $Tr$  side.

Connect  $R_{SENSE}$  of  $GND$  side isolated to  $SENS$  pin. Don't wire between  $R_{SENSE}$  and  $SENSN$  pin wiring from  $SENSN$  pin to  $GND$  pin. After via  $SENSN$  pin, connect  $GND$  pin, as shown in the upper diagram.

Connect LED current setting resistor  $R_{ISET}$  nearest to  $ISET$  pin. There is possibility to oscillate when capacity is added to  $ISET$  terminal, so pay attention that capacity isn't added. And, connect  $R_{ISET}$  of  $GND$  side directly to  $GND$  pin.

When those pins are not connected directly near the chip, influence is given to the performance of  $BD6066GU/EKN$ , and may limit the current drive performance. As for the wire to the inductor, make its resistance component small so as to reduce electric power consumption and increase the entire efficiency.

The PCB layout in consideration of these is shown in the next page.

●Recommended PCB layout

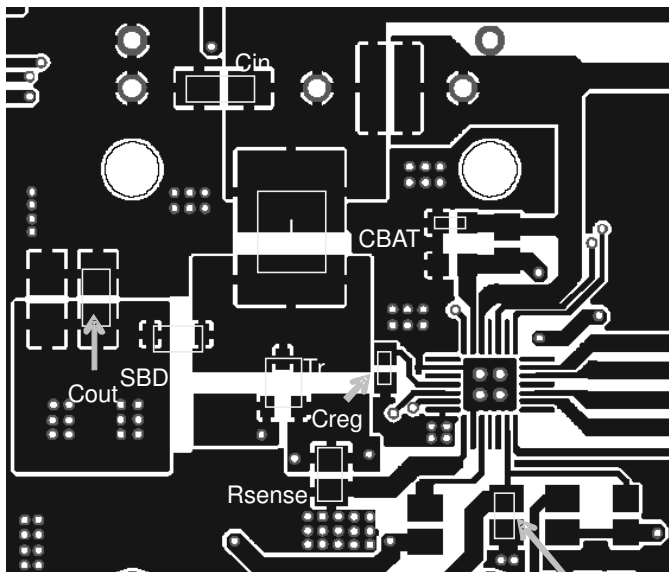

Fig.33 BD6066EKN Component side (Top view) R1SET

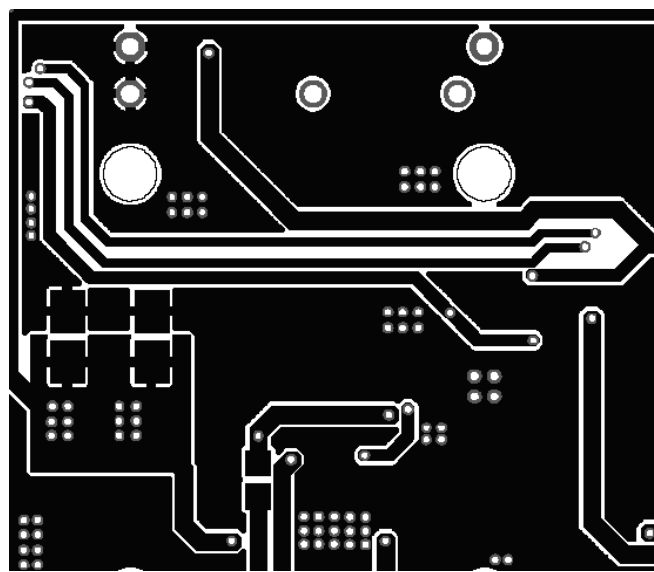

Fig.34 BD6066EKN Back side (Top view)

●Attention point of PCB layout

In PCB layout design, the wiring of power supply line should be low Impedance, and put the bypass capacitor if necessary. Especially the wiring impedance must be lower around the DC/DC converter.

●About heat loss

In heat design, operate the DC/DC converter in the following condition.  
(The following temperature is a guarantee temperature, so consider the margin.)

1. Periphery temperature Ta must be less than 85°C
2. The loss of IC must be less than dissipation Pd.

## ●Notes for use

- (1) Absolute Maximum Ratings  
An excess in the absolute maximum ratings, such as supply voltage, temperature range of operating conditions, etc., can break down devices, thus making impossible to identify breaking mode such as a short circuit or an open circuit. If any special mode exceeding the absolute maximum ratings is assumed, consideration should be given to take physical safety measures including the use of fuses, etc.
- (2) Operating conditions  
These conditions represent a range within which characteristics can be provided approximately as expected. The electrical characteristics are guaranteed under the conditions of each parameter.
- (3) Reverse connection of power supply connector  
The reverse connection of power supply connector can break down ICs. Take protective measures against the breakdown due to the reverse connection, such as mounting an external diode between the power supply and the IC's power supply terminal.
- (4) Power supply line  
Design PCB pattern to provide low impedance for the wiring between the power supply and the GND lines. In this regard, for the digital block power supply and the analog block power supply, even though these power supplies has the same level of potential, separate the power supply pattern for the digital block from that for the analog block, thus suppressing the diffraction of digital noises to the analog block power supply resulting from impedance common to the wiring patterns. For the GND line, give consideration to design the patterns in a similar manner. Furthermore, for all power supply terminals to ICs, mount a capacitor between the power supply and the GND terminal. At the same time, in order to use an electrolytic capacitor, thoroughly check to be sure the characteristics of the capacitor to be used present no problem including the occurrence of capacity dropout at a low temperature, thus determining the constant.
- (5) GND voltage  
Make setting of the potential of the GND terminal so that it will be maintained at the minimum in any operating state. Furthermore, check to be sure no terminals are at a potential lower than the GND voltage including an actual electric transient.
- (6) Short circuit between terminals and erroneous mounting  
In order to mount ICs on a set PCB, pay thorough attention to the direction and offset of the ICs. Erroneous mounting can break down the ICs. Furthermore, if a short circuit occurs due to foreign matters entering between terminals or between the terminal and the power supply or the GND terminal, the ICs can break down.
- (7) Operation in strong electromagnetic field  
Be noted that using ICs in the strong electromagnetic field can malfunction them.
- (8) Inspection with set PCB  
On the inspection with the set PCB, if a capacitor is connected to a low-impedance IC terminal, the IC can suffer stress. Therefore, be sure to discharge from the set PCB by each process. Furthermore, in order to mount or dismount the set PCB to/from the jig for the inspection process, be sure to turn OFF the power supply and then mount the set PCB to the jig. After the completion of the inspection, be sure to turn OFF the power supply and then dismount it from the jig. In addition, for protection against static electricity, establish a ground for the assembly process and pay thorough attention to the transportation and the storage of the set PCB.
- (9) Input terminals  
In terms of the construction of IC, parasitic elements are inevitably formed in relation to potential. The operation of the parasitic element can cause interference with circuit operation, thus resulting in a malfunction and then breakdown of the input terminal. Therefore, pay thorough attention not to handle the input terminals, such as to apply to the input terminals a voltage lower than the GND respectively, so that any parasitic element will operate. Furthermore, do not apply a voltage to the input terminals when no power supply voltage is applied to the IC. In addition, even if the power supply voltage is applied, apply to the input terminals a voltage lower than the power supply voltage or within the guaranteed value of electrical characteristics.
- (10) Ground wiring pattern  
If small-signal GND and large-current GND are provided, It will be recommended to separate the large-current GND pattern from the small-signal GND pattern and establish a single ground at the reference point of the set PCB so that resistance to the wiring pattern and voltage fluctuations due to a large current will cause no fluctuations in voltages of the small-signal GND. Pay attention not to cause fluctuations in the GND wiring pattern of external parts as well.
- (11) External capacitor  
In order to use a ceramic capacitor as the external capacitor, determine the constant with consideration given to a degradation in the nominal capacitance due to DC bias and changes in the capacitance due to temperature, etc.
- (12) Thermal shutdown circuit (TSD)  
When junction temperatures become 175°C (typ) or higher, the thermal shutdown circuit operates and turns a switch OFF. The thermal shutdown circuit, which is aimed at isolating the LSI from thermal runaway as much as possible, is not aimed at the protection or guarantee of the LSI. Therefore, do not continuously use the LSI with this circuit operating or use the LSI assuming its operation.
- (13) Thermal design  
Perform thermal design in which there are adequate margins by taking into account the permissible dissipation (Pd) in actual states of use.
- (14) Selection of coil  
Select the low DCR inductors to decrease power loss for DC/DC converter.

●Ordering part number

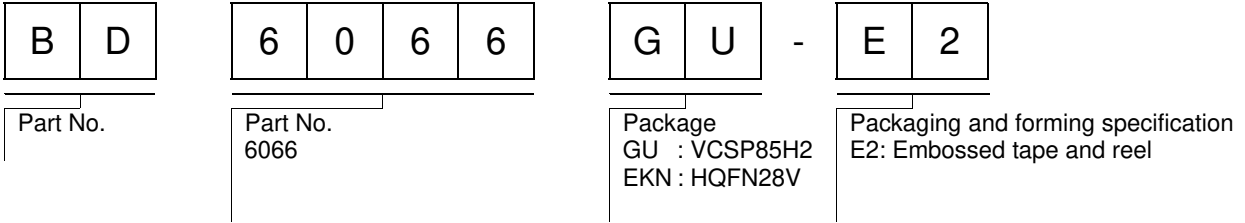

VCSP85H2 (BD6066GU)

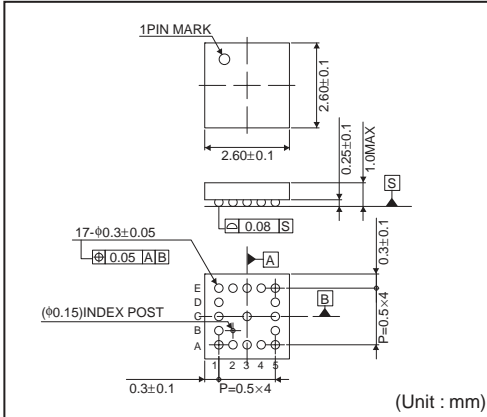

<Tape and Reel information>

Tape	Embossed carrier tape
Quantity	3000pcs
Direction of feed	E2 ( The direction is the 1pin of product is at the upper left when you hold reel on the left hand and you pull out the tape on the right hand )

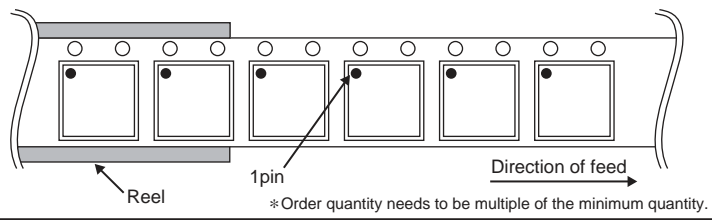

HQFN28V

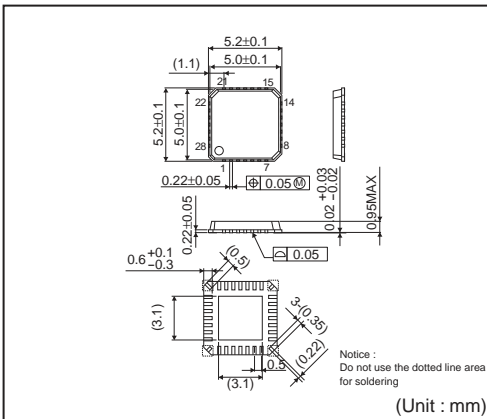

<Tape and Reel information>

Tape	Embossed carrier tape (with dry pack)
Quantity	2500pcs
Direction of feed	E2 ( The direction is the 1pin of product is at the upper left when you hold reel on the left hand and you pull out the tape on the right hand )

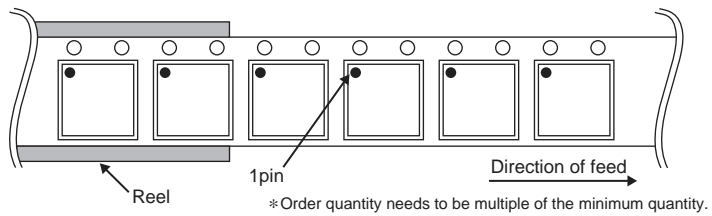

# Notice

## Precaution on using ROHM Products

- Our Products are designed and manufactured for application in ordinary electronic equipments (such as AV equipment, OA equipment, telecommunication equipment, home electronic appliances, amusement equipment, etc.). If you intend to use our Products in devices requiring extremely high reliability (such as medical equipment <sup>(Note 1)</sup>, transport equipment, traffic equipment, aircraft/spacecraft, nuclear power controllers, fuel controllers, car equipment including car accessories, safety devices, etc.) and whose malfunction or failure may cause loss of human life, bodily injury or serious damage to property ("Specific Applications"), please consult with the ROHM sales representative in advance. Unless otherwise agreed in writing by ROHM in advance, ROHM shall not be in any way responsible or liable for any damages, expenses or losses incurred by you or third parties arising from the use of any ROHM's Products for Specific Applications.

(Note1) Medical Equipment Classification of the Specific Applications

JAPAN	USA	EU	CHINA
CLASS III	CLASS III	CLASS II b	CLASS III
CLASS IV		CLASS III	

- ROHM designs and manufactures its Products subject to strict quality control system. However, semiconductor products can fail or malfunction at a certain rate. Please be sure to implement, at your own responsibilities, adequate safety measures including but not limited to fail-safe design against the physical injury, damage to any property, which a failure or malfunction of our Products may cause. The following are examples of safety measures:
  - Installation of protection circuits or other protective devices to improve system safety
  - Installation of redundant circuits to reduce the impact of single or multiple circuit failure
- Our Products are designed and manufactured for use under standard conditions and not under any special or extraordinary environments or conditions, as exemplified below. Accordingly, ROHM shall not be in any way responsible or liable for any damages, expenses or losses arising from the use of any ROHM's Products under any special or extraordinary environments or conditions. If you intend to use our Products under any special or extraordinary environments or conditions (as exemplified below), your independent verification and confirmation of product performance, reliability, etc. prior to use, must be necessary:
  - Use of our Products in any types of liquid, including water, oils, chemicals, and organic solvents
  - Use of our Products outdoors or in places where the Products are exposed to direct sunlight or dust
  - Use of our Products in places where the Products are exposed to sea wind or corrosive gases, including Cl<sub>2</sub>, H<sub>2</sub>S, NH<sub>3</sub>, SO<sub>2</sub>, and NO<sub>2</sub>
  - Use of our Products in places where the Products are exposed to static electricity or electromagnetic waves
  - Use of our Products in proximity to heat-producing components, plastic cords, or other flammable items
  - Sealing or coating our Products with resin or other coating materials
  - Use of our Products without cleaning residue of flux (even if you use no-clean type fluxes, cleaning residue of flux is recommended); or Washing our Products by using water or water-soluble cleaning agents for cleaning residue after soldering
  - Use of the Products in places subject to dew condensation
- The Products are not subject to radiation-proof design.
- Please verify and confirm characteristics of the final or mounted products in using the Products.
- In particular, if a transient load (a large amount of load applied in a short period of time, such as pulse. is applied, confirmation of performance characteristics after on-board mounting is strongly recommended. Avoid applying power exceeding normal rated power; exceeding the power rating under steady-state loading condition may negatively affect product performance and reliability.
- De-rate Power Dissipation (Pd) depending on Ambient temperature (Ta). When used in sealed area, confirm the actual ambient temperature.
- Confirm that operation temperature is within the specified range described in the product specification.
- ROHM shall not be in any way responsible or liable for failure induced under deviant condition from what is defined in this document.

## Precaution for Mounting / Circuit board design

- When a highly active halogenous (chlorine, bromine, etc.) flux is used, the residue of flux may negatively affect product performance and reliability.
- In principle, the reflow soldering method must be used; if flow soldering method is preferred, please consult with the ROHM representative in advance.

For details, please refer to ROHM Mounting specification



**Precautions Regarding Application Examples and External Circuits**

1. If change is made to the constant of an external circuit, please allow a sufficient margin considering variations of the characteristics of the Products and external components, including transient characteristics, as well as static characteristics.
2. You agree that application notes, reference designs, and associated data and information contained in this document are presented only as guidance for Products use. Therefore, in case you use such information, you are solely responsible for it and you must exercise your own independent verification and judgment in the use of such information contained in this document. ROHM shall not be in any way responsible or liable for any damages, expenses or losses incurred by you or third parties arising from the use of such information.

**Precaution for Electrostatic**

This Product is electrostatic sensitive product, which may be damaged due to electrostatic discharge. Please take proper caution in your manufacturing process and storage so that voltage exceeding the Products maximum rating will not be applied to Products. Please take special care under dry condition (e.g. Grounding of human body / equipment / solder iron, isolation from charged objects, setting of Ionizer, friction prevention and temperature / humidity control).

**Precaution for Storage / Transportation**

1. Product performance and soldered connections may deteriorate if the Products are stored in the places where:
  - [a] the Products are exposed to sea winds or corrosive gases, including Cl<sub>2</sub>, H<sub>2</sub>S, NH<sub>3</sub>, SO<sub>2</sub>, and NO<sub>2</sub>
  - [b] the temperature or humidity exceeds those recommended by ROHM
  - [c] the Products are exposed to direct sunshine or condensation
  - [d] the Products are exposed to high Electrostatic
2. Even under ROHM recommended storage condition, solderability of products out of recommended storage time period may be degraded. It is strongly recommended to confirm solderability before using Products of which storage time is exceeding the recommended storage time period.
3. Store / transport cartons in the correct direction, which is indicated on a carton with a symbol. Otherwise bent leads may occur due to excessive stress applied when dropping of a carton.
4. Use Products within the specified time after opening a humidity barrier bag. Baking is required before using Products of which storage time is exceeding the recommended storage time period.

**Precaution for Product Label**

QR code printed on ROHM Products label is for ROHM's internal use only.

**Precaution for Disposition**

When disposing Products please dispose them properly using an authorized industry waste company.

**Precaution for Foreign Exchange and Foreign Trade act**

Since our Products might fall under controlled goods prescribed by the applicable foreign exchange and foreign trade act, please consult with ROHM representative in case of export.

**Precaution Regarding Intellectual Property Rights**

1. All information and data including but not limited to application example contained in this document is for reference only. ROHM does not warrant that foregoing information or data will not infringe any intellectual property rights or any other rights of any third party regarding such information or data. ROHM shall not be in any way responsible or liable for infringement of any intellectual property rights or other damages arising from use of such information or data.:
2. No license, expressly or implied, is granted hereby under any intellectual property rights or other rights of ROHM or any third parties with respect to the information contained in this document.

**Other Precaution**

1. This document may not be reprinted or reproduced, in whole or in part, without prior written consent of ROHM.
2. The Products may not be disassembled, converted, modified, reproduced or otherwise changed without prior written consent of ROHM.
3. In no event shall you use in any way whatsoever the Products and the related technical information contained in the Products or this document for any military purposes, including but not limited to, the development of mass-destruction weapons.
4. The proper names of companies or products described in this document are trademarks or registered trademarks of ROHM, its affiliated companies or third parties.

### General Precaution

1. Before you use our Products, you are requested to carefully read this document and fully understand its contents. ROHM shall not be in any way responsible or liable for failure, malfunction or accident arising from the use of any ROHM's Products against warning, caution or note contained in this document.
2. All information contained in this document is current as of the issuing date and subject to change without any prior notice. Before purchasing or using ROHM's Products, please confirm the latest information with a ROHM sales representative.
3. The information contained in this document is provided on an "as is" basis and ROHM does not warrant that all information contained in this document is accurate and/or error-free. ROHM shall not be in any way responsible or liable for any damages, expenses or losses incurred by you or third parties resulting from inaccuracy or errors of or concerning such information.