

Features

- ◆ True Dual-Ported memory cells which allow simultaneous reads of the same memory location
- ◆ One port with dedicated time-multiplexed address/data (ADM) interface
- ◆ One port configurable to standard SRAM or time-multiplexed address/data interface
- ◆ High-speed access
 - Industrial: 65ns (max.), ADM mode
 - Industrial: 40ns (max.), Standard SRAM mode
- ◆ Low-power operation
IDT70P265/255/245L
Active: 27mW (typ.)
Standby: 3.6µW (typ.)
- ◆ Power supply isolation functionality to aid system power management
- ◆ Separate upper-byte and lower-byte control
- ◆ Supports 3.0V, 2.5V and 1.8V I/O's
- ◆ Input Read Register
- ◆ Output Drive Register
- ◆ $\overline{\text{BUSY}}$ and Interrupt Flag
- ◆ On-chip port arbitration logic
- ◆ Fully asynchronous operation from either port
- ◆ Available in 100 Ball 0.5mm-pitch BGA
- ◆ Industrial temperature range (-40°C to +85°C)
- ◆ Green parts available, see ordering information

Functional Block Diagram

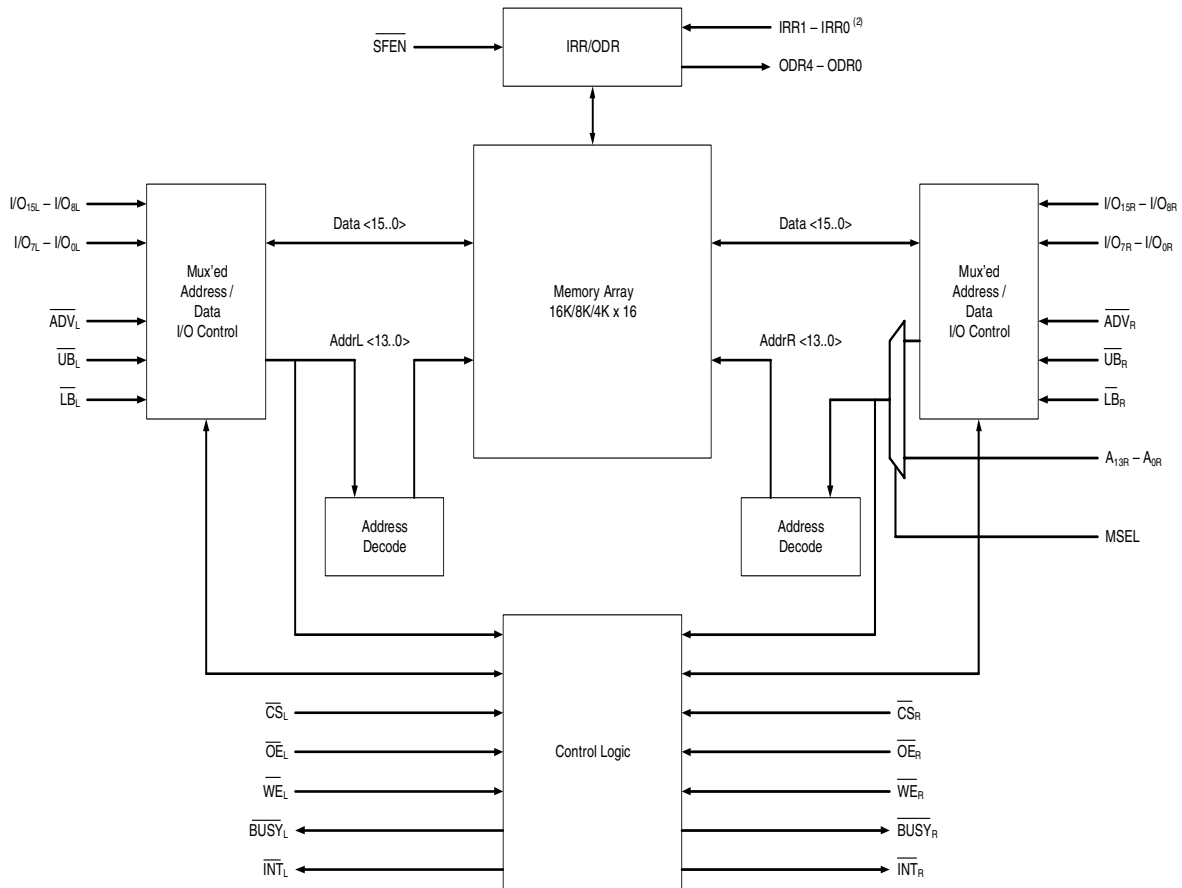

7145 drw 01

NOTES:

1. A13 - A0 for IDT70P265; A12 - A0 for IDT70P255; A11 - A0 for IDT70P245.
2. IRR0 and IRR1 are not available for IDT70P265.

SEPTEMBER 2011

Description

The IDT70P265/255/245 is a very low power 16K/8K/4K x 16 Dual-Port Static RAM. The IDT70P265/255/245 is designed to be used as a stand-alone 256/128/64K-bit Dual-Port SRAM.

This device provides two independent ports with separate control, address, and I/O pins that permit independent, asynchronous access for reads or writes to any location in memory. An automatic power down feature controlled by \overline{CS} permits the on-chip circuitry of each port to enter a very low standby power mode.

Fabricated using IDT's CMOS high-performance technology, these devices typically operate on only 27mW of power.

The IDT70P265/255/245 is packaged in a 100 ball 0.5mm-pitch Ball Grid Array. The package is a 1mm thick and designed to fit in wireless handset applications.

Pin Configurations^(2,3)

70P265/255/245BY BY-100

100-Ball 0.5mm Pitch BGA Top View

	1	2	3	4	5	6	7	8	9	10	
A	A _{5R}	A _{8R}	A _{11R}	\overline{UB}_R	V _{SS}	\overline{ADV}_R	I/O _{15R}	I/O _{12R}	I/O _{10R}	V _{SS}	A
B	A _{3R}	A _{4R}	A _{7R}	A _{9R}	\overline{CS}_R	\overline{WE}_R	\overline{OE}_R	V _{DDIOR}	I/O _{9R}	I/O _{6R}	B
C	A _{0R}	A _{1R}	A _{2R}	A _{6R}	\overline{LB}_R	IRR ₁ ⁽¹⁾	I/O _{14R}	I/O _{11R}	I/O _{7R}	V _{SS}	C
D	ODR ₄	ODR ₂	\overline{BUSY}_R	\overline{INT}_R	A _{10R}	A _{12R} ⁽³⁾	I/O _{13R}	I/O _{8R}	I/O _{5R}	I/O _{2R}	D
E	V _{SS}	DNU ⁽⁴⁾	ODR ₃	\overline{INT}_L	V _{SS}	V _{SS}	I/O _{4R}	V _{DDIOR}	I/O _{1R}	V _{SS}	E
F	\overline{SFEN}	ODR ₁	\overline{BUSY}_L	DNU ⁽⁴⁾	V _{DD}	V _{SS}	I/O _{3R}	I/O _{0R}	I/O _{15L}	V _{DDIOL}	F
G	ODR ₀	DNU ⁽⁴⁾	DNU ⁽⁴⁾	DNU ⁽⁴⁾	\overline{OE}_L	I/O _{3L}	I/O _{11L}	I/O _{12L}	I/O _{14L}	I/O _{13L}	G
H	DNU ⁽⁴⁾	DNU ⁽⁴⁾	DNU ⁽⁴⁾	\overline{LB}_L	\overline{CS}_L	I/O _{1L}	V _{DDIOL}	MSEL	DNU ⁽⁴⁾	I/O _{10L}	H
J	DNU ⁽⁴⁾	DNU ⁽⁴⁾	DNU ⁽⁴⁾	IRR ₀ ⁽²⁾	V _{DD}	V _{SS}	I/O _{4L}	I/O _{6L}	I/O _{8L}	I/O _{9L}	J
K	DNU ⁽⁴⁾	DNU ⁽⁴⁾	DNU ⁽⁴⁾	\overline{UB}_L	\overline{ADV}_L	\overline{WE}_L	I/O _{0L}	I/O _{2L}	I/O _{5L}	I/O _{7L}	K
	1	2	3	4	5	6	7	8	9	10	

7145 drw 02

NOTES:-

1. This pin is A_{13R} for IDT70P265.
2. This pin is DNU for IDT70P265.
3. This pin is DNU for IDT70P245.
4. DNU pins are "do not use". No trace or power component can be connected to these pins.

Pin Names

Left Port	Right Port	Description
\overline{CS}_L	\overline{CS}_R	Chip Select (Input)
\overline{WE}_L	\overline{WE}_R	Read/Write Enable (Input)
\overline{OE}_L	\overline{OE}_R	Output Enable (Input)
	A0R - A13R ⁽¹⁾	Address (Input)
	MSEL ⁽²⁾	Mode Select (Input)
I/O0L - I/O15L	I/O0R - I/O15R	Address/Data (Input/Output)
\overline{ADV}_L	\overline{ADV}_R ⁽³⁾	Address Latch Enable (Input)
\overline{UB}_L	\overline{UB}_R	Upper Byte Enable (Input)
\overline{LB}_L	\overline{LB}_R	Lower Byte Enable (Input)
\overline{INT}_L	\overline{INT}_R	Interrupt Flag (Output)
\overline{BUSY}_L	\overline{BUSY}_R	Busy Flag (Output)
SFEN		Special Function Enable (Input)
IRR0 - IRR1 ⁽⁴⁾		Input Read Register (Inputs)
ODR0 - ODR4		Output Drive Register (Outputs)
VDD		Core Power Supply (Input)
VSS		Ground (Input)
VDDIOL		Left Port Power Supply (Input)
VDDIOR		Right Port Power Supply (Input)
DNU		Do Not Use

7145 tbl 01

NOTES:

1. A13 - A0 for IDT70P265; A12 - A0 for IDT70P255; A11 - A0 for IDT70P245.
2. MSEL = 0 for Standard SRAM operation, MSEL = 1 for Address/Data Mux (ADM) operation.
3. \overline{ADV}_R is only used when the right port is in ADM mode.
4. IRR0 is DNU and IRR1 is A13R for 70P265.

Truth Table I: ADM Interface Read/Write Control

Inputs						Outputs	Mode
ADV	\overline{CS}	\overline{WE}	\overline{OE}	\overline{UB}	\overline{LB}	I/O0 - I/O15	
X	H	X	X	X	X	High-Z	Deselected/Power Down
X	X	X	H	X	X	High-Z	Output Disable
X	X	X	X	H	H	High-Z	Upper and Lower Bytes Deselected
Pulse	L	H	L	L	L	DATAOUT (I/O0 - I/O15)	Read Upper and Lower Bytes
Pulse	L	H	L	H	L	DATAOUT (I/O0 - I/O7) High-Z (I/O8 - I/O15)	Read Lower Byte Only
Pulse	L	H	L	L	H	High-Z (I/O0 - I/O7) DATAOUT (I/O8 - I/O15)	Read Upper Byte Only
Pulse	L	L	X	L	L	DATAIN (I/O0 - I/O15)	Write Upper and Lower Bytes
Pulse	L	L	X	H	L	DATAIN (I/O0 - I/O7) High-Z (I/O8 - I/O15)	Write Lower Byte Only
Pulse	L	L	X	L	H	High-Z (I/O0 - I/O7) DATAIN (I/O8 - I/O15)	Write Upper Byte Only

7145 tbl 02a

Truth Table II: Standard SRAM Interface Read/Write Control

Inputs					Outputs	Mode
\overline{CS}	\overline{WE}	\overline{OE}	\overline{UB}	\overline{LB}	I/O ₀ - I/O ₁₅	
H	X	X	X	X	High-Z	Deselected/Power Down
X	X	H	X	X	High-Z	Output Disable
X	X	X	H	H	High-Z	Upper and Lower Bytes Deselected
L	H	L	L	L	DATA _{OUT} (I/O ₀ - I/O ₁₅)	Read Upper and Lower Bytes
L	H	L	H	L	DATA _{OUT} (I/O ₀ - I/O ₇) High-Z (I/O ₈ - I/O ₁₅)	Read Lower Byte Only
L	H	L	L	H	High-Z (I/O ₀ - I/O ₇) DATA _{OUT} (I/O ₈ - I/O ₁₅)	Read Upper Byte Only
L	L	X	L	L	DATA _{IN} (I/O ₀ - I/O ₁₅)	Write Upper and Lower Bytes
L	L	X	H	L	DATA _{IN} (I/O ₀ - I/O ₇) High-Z (I/O ₈ - I/O ₁₅)	Write Lower Byte Only
L	L	X	L	H	High-Z (I/O ₀ - I/O ₇) DATA _{IN} (I/O ₈ - I/O ₁₅)	Write Upper Byte Only

7145 tbl 02b

Absolute Maximum Ratings⁽¹⁾

Symbol	Rating	Commercial & Industrial	Unit
V _{TERM} ⁽²⁾	Terminal Voltage with Respect to GND	-0.5 to V _{DDIOX} + 0.5	V
T _{BIAS} ⁽³⁾	Temperature Under Bias	-55 to +125	°C
T _{STG}	Storage Temperature	-65 to +150	°C
T _{JN}	Junction Temperature	+150	°C
I _{OUT}	DC Output Current	20	mA

NOTES:

7145 tbl 03

- Stresses greater than those listed under ABSOLUTE MAXIMUM RATINGS may cause permanent damage to the device. This is a stress rating only and functional operation of the device at these or any other conditions above those indicated in the operational sections of this specification is not implied. Exposure to absolute maximum rating conditions for extended periods may affect reliability.
- V_{TERM} must not exceed V_{DDIOX} + 0.5V for more than 25% of the cycle time or 10ns maximum, and is limited to ≤ 20mA for the period over V_{TERM} = V_{DDIOX} + 0.5V.
- Ambient Temperature under DC Bias. No AC Conditions. Chip Deselected.

Capacitance (TA = +25°C, f = 1.0MHz)

Symbol	Parameter	Conditions ⁽²⁾	Max.	Unit
C _{IN}	Input Capacitance	V _{IN} = 3dV	9	pF
C _{OUT}	Output Capacitance	V _{OUT} = 3dV	10	pF

7145 tbl 05

NOTES:

- This parameter is determined by device characterization but is not production tested.
- 3dV references the interpolated capacitance when the input and output signals switch from 0V to 3V or from 3V to 0V.

Maximum Operating Temperature and Supply Voltage⁽¹⁾

Grade	Ambient Temperature	GND	V _{DD}
Industrial	-40°C to +85°C	0V	1.8V ± 100mV 2.5V ± 100mV 3.0V ± 300mV

7145 tbl 04

NOTE :

- This is the parameter TA. This is the "instant on" case temperature.

DC Electrical Characteristics Over the Operating and Temperature and Supply Voltage Range (V_{DD} = 1.8V)

Symbol	Parameter	P1 I/O Voltage	P2 I/O Voltage	70P265/255/245 Ind'l Only			
				Min.	Typ.	Max.	Unit
V _{OH}	Output High Voltage (I _{OH} = -100 μA)	1.8V (any port)		V _{DDIO} - 0.2	—	—	V
	Output High Voltage (I _{OH} = -2 mA)	2.5V (any port)		2.0	—	—	V
	Output High Voltage (I _{OH} = -2 mA)	3.0V (any port)		2.1	—	—	V
V _{OL}	Output Low Voltage (I _{OL} = 100 μA)	1.8V (any port)		—	—	0.2	V
	Output Low Voltage (I _{OL} = 2 mA)	2.5V (any port)		—	—	0.4	V
	Output Low Voltage (I _{OL} = 2 mA)	3.0V (any port)		—	—	0.4	V
V _{OL} ODR	ODR Output Low Voltage (I _{OL} = 8 mA)	1.8V (any port)		—	—	0.2	V
		2.5V (any port)		—	—	0.2	V
		3.0V (any port)		—	—	0.2	V
V _{IH}	Input High Voltage	1.8V (any port)		1.2	—	V _{DDIO} + 0.2	V
		2.5V (any port)		1.7	—	V _{DDIO} + 0.3	V
		3.0V (any port)		2.0	—	V _{DDIO} + 0.2	V
V _{IL}	Input Low Voltage	1.8V (any port)		-0.2	—	0.4	V
		2.5V (any port)		-0.3	—	0.6	V
		3.0V (any port)		-0.2	—	0.7	V
I _{oz}	Output Leakage Current	1.8V	1.8V	-1	—	1	μA
		2.5V	2.5V	-1	—	1	
		3.0V	3.0V	-1	—	1	
I _{CEx} ODR	ODR Output Leakage Current V _{OUT} = V _{DDIO}	1.8V	1.8V	-1	—	1	μA
		2.5V	2.5V	-1	—	1	
		3.0V	3.0V	-1	—	1	
I _{Ix}	Input Leakage Current	1.8V	1.8V	-1	—	1	μA
		2.5V	2.5V	-1	—	1	
		3.0V	3.0V	-1	—	1	

7145 tbl 06

DC Electrical Characteristics Over the Operating and Temperature and Supply Voltage Range ($V_{DD} = 2.5V$)

Symbol	Parameter	P1 I/O Voltage	P2 I/O Voltage	70P265/255/245 Ind'l Only			
				Min.	Typ.	Max.	Unit
V _{OH}	Output High Voltage (I _{OH} = -2 mA)	2.5V (any port)		2.0	—	—	V
	Output High Voltage (I _{OH} = -2 mA)	3.0V (any port)		2.1	—	—	V
V _{OL}	Output Low Voltage (I _{OL} = 2 mA)	2.5V (any port)		—	—	0.4	V
	Output Low Voltage (I _{OL} = 2 mA)	3.0V (any port)		—	—	0.4	V
V _{OL} ODR	ODR Output Low Voltage (I _{OL} = 8 mA)	2.5V (any port)		—	—	0.2	V
		3.0V (any port)		—	—	0.2	V
V _{IH}	Input High Voltage	2.5V (any port)		1.7	—	V _{DDIO} + 0.3	V
		3.0V (any port)		2.0	—	V _{DDIO} + 0.2	V
V _{IL}	Input Low Voltage	2.5V (any port)		-0.3	—	0.6	V
		3.0V (any port)		-0.2	—	0.7	V
I _{OZ}	Output Leakage Current	2.5V	2.5V	-1	—	1	μA
		3.0V	3.0V	-1	—	1	
I _{CEX} ODR	ODR Output Leakage Current V _{OUT} = V _{DDIO}	2.5V	2.5V	-1	—	1	μA
		3.0V	3.0V	-1	—	1	
I _{IX}	Input Leakage Current	2.5V	2.5V	-1	—	1	μA
		3.0V	3.0V	-1	—	1	

7145 tbl 07

DC Electrical Characteristics Over the Operating and Temperature and Supply Voltage Range ($V_{DD} = 3.0V$)

Symbol	Parameter	P1 I/O Voltage	P2 I/O Voltage	70P265/255/245 Ind'l Only			
				Min.	Typ.	Max.	Unit
V _{OH}	Output High Voltage (I _{OH} = -2 mA)	3.0V (any port)		2.1	—	—	V
V _{OL}	Output Low Voltage (I _{OL} = 2 mA)	3.0V (any port)		—	—	0.4	V
V _{OL} ODR	ODR Output Low Voltage (I _{OL} = 8 mA)	3.0V (any port)		—	—	0.2	V
V _{IH}	Input High Voltage	3.0V (any port)		2.0	—	V _{DDIO} + 0.2	V
V _{IL}	Input Low Voltage	3.0V (any port)		-0.2	—	0.7	V
I _{OZ}	Output Leakage Current	3.0V	3.0V	-1	—	1	μA
I _{CEX} ODR	ODR Output Leakage Current V _{OUT} = V _{DDIO}	3.0V	3.0V	-1	—	1	μA
I _{IX}	Input Leakage Current	3.0V	3.0V	-1	—	1	μA

7145 tbl 08

DC Electrical Characteristics Over the Operating and Temperature and Supply Voltage Range

Symbol	Parameter	Test Condition ⁽¹⁾	VDD	70P265/255/245 Ind'l Only				Unit
				65 ns		90 ns		
				Typ.	Max.	Typ.	Max.	
IDD	Dynamic Operating Current	VDD = MAX, IOUT = 0mA	1.8V	25	40	15	25	mA
			2.5V	39	55	28	40	
			3.0V	49	70	42	60	
ISB1	Standby Current (Both Ports Inactive)	\overline{CS}_R and $\overline{CS}_L \geq V_{DDIO} - 0.2V$, MSEL $\leq 0.2V$ or $\geq V_{DDIO} - 0.2V$, f = fMAX	1.8V	2	6	2	6	μA
			2.5V	6	8	6	8	
			3.0V	7	10	7	10	
ISB2	Standby Current (One Port Active, One Port Inactive)	\overline{CS}_R or $\overline{CS}_L \geq V_{DDIO} - 0.2V$, f = fMAX	1.8V	8.5	18	8.5	14	mA
			2.5V	21	30	18	25	
			3.0V	28	40	25	35	
ISB3	Full Standby Current (Both Ports Inactive - CMOS Level Inputs)	\overline{CS}_R and $\overline{CS}_L \geq V_{DDIO} - 0.2V$, MSEL $\leq 0.2V$ or $\geq V_{DDIO} - 0.2V$, f = 0	1.8V	2	6	2	6	μA
			2.5V	4	6	4	6	
			3.0V	6	8	6	8	
ISB4	Standby Current (One Port Active, One Port Inactive - CMOS Level Inputs)	\overline{CS}_L or $\overline{CS}_R \geq V_{DDIO} - 0.2V$, f = fMAX	1.8V	8.5	18	8.5	14	mA
			2.5V	21	30	18	25	
			3.0V	28	40	25	35	

7145 tbl 09

NOTE :

1. fMAX = 1/trc = All inputs cycling at f = 1/trc (except output enable). f=0 means no address or control lines change. This applied only to inputs at CMOS level standby ISB3.

AC Test Conditions

Input Pulse Levels	GND to 3.0V/GND to 2.5V/GND to 1.8V
Input Rise/Fall Times	3ns Max.
Input Timing Reference Levels	1.5V/1.25V/0.9V
Output Reference Levels	1.5V/1.25V/0.9V
Output Load	Figure 1

7145 tbl 10

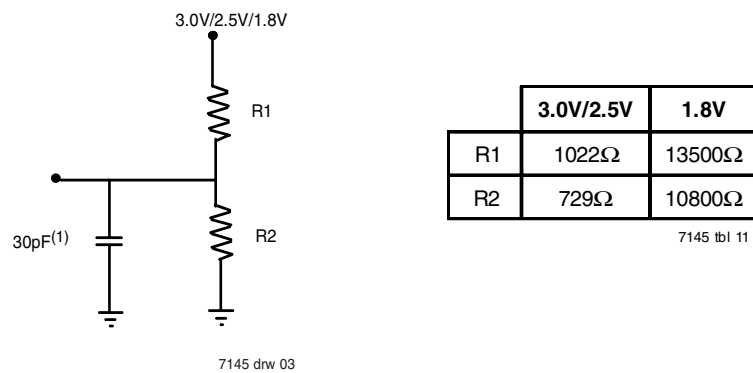
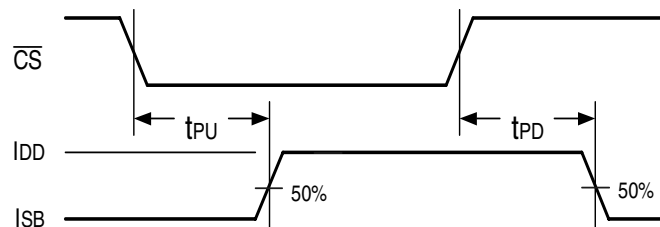

Figure 1. AC Output Test Load
 (5pF for tLZ, tHZ, tWZ, tOW)

Timing of Power-Up Power-Down



AC Electrical Characteristics Over the Operating Temperature and Supply Voltage Range⁽¹⁾

Symbol	Parameter	70P265/255/245				Unit
		65 ns		90 ns		
		Min.	Max.	Min.	Max.	
ADM Port Read Cycle⁽²⁾						
t _{RC}	Read Cycle Time	65	—	90	—	ns
t _{ACC1}	Random Access \overline{ADV} Low to Data Valid	—	65	—	90	ns
t _{ACC2}	Random Access Address to Data Valid	—	65	—	90	ns
t _{ACC3}	Random Access \overline{CS} to Data Valid	—	65	—	90	ns
t _{AVDA}	Random Access \overline{ADV} High to Data Valid	—	35	—	50	ns
t _{AVD}	\overline{ADV} Low Pulse	7	—	20	—	ns
t _{AVDS}	Address Set-up to \overline{ADV} Rising Edge	7	—	20	—	ns
t _{AVDH}	Address Hold from \overline{ADV} Rising Edge	3	—	5	—	ns
t _{CSS}	\overline{CS} Set-up to \overline{ADV} Rising Edge	7	—	10	—	ns
t _{OE}	\overline{OE} Low to Data Valid	—	35	—	50	ns
t _{LZOE} ⁽³⁾	\overline{OE} Low to I/O Low-Z	3	—	5	—	ns
t _{HZOE} ⁽³⁾	\overline{OE} High to I/O High-Z	—	15	—	25	ns
t _{HZCS} ⁽³⁾	\overline{CS} High to I/O High-Z	—	15	—	25	ns
t _{DBE}	$\overline{UB}/\overline{LB}$ Low to I/O Valid	—	35	—	50	ns
t _{LZBE} ⁽³⁾	$\overline{UB}/\overline{LB}$ Low to I/O Low-Z	3	—	5	—	ns
t _{HZBE} ⁽³⁾	$\overline{UB}/\overline{LB}$ High to I/O High-Z	—	15	—	25	ns
t _{AVOE}	\overline{ADV} High to \overline{OE} Low	0	—	0	—	ns
t _{PU}	Chip Enable to Power Up Time	0	—	0	—	ns
t _{PD}	Chip Disable to Power Down Time	—	65	—	90	ns
Standard Port Read Cycle⁽⁴⁾						
t _{RC}	Read Cycle Time	40	—	60	—	ns
t _{AA}	Address to Data Valid	—	40	—	60	ns
t _{OHA}	Output Hold from Address Change	5	—	5	—	ns
t _{ACS}	\overline{CS} to Data Valid	—	40	—	60	ns
t _{DOE}	\overline{OE} Low to Data Valid	—	25	—	35	ns
t _{LZOE} ⁽³⁾	\overline{OE} Low to Data Low-Z	5	—	5	—	ns
t _{HZOE} ⁽³⁾	\overline{OE} High to Data High-Z	—	10	—	30	ns
t _{LZCS} ⁽³⁾	\overline{CS} Low to Data Low-Z	5	—	5	—	ns
t _{HZCS} ⁽³⁾	\overline{CS} Low to Data High-Z	—	10	—	30	ns
t _{LZBE} ⁽³⁾	$\overline{UB}/\overline{LB}$ Low to Data Low-Z	5	—	5	—	ns
t _{HZBE} ⁽³⁾	$\overline{UB}/\overline{LB}$ High to Data High-Z	—	10	—	30	ns
t _{ABE}	$\overline{UB}/\overline{LB}$ Access Time	—	40	—	60	ns

7145 tbl 12b

NOTES:

1. VDD = 1.8V
2. ADM port timing applies to left ADM port and right port configured to ADM mode.
3. This parameter is guaranteed by design and is not tested.
4. Standard SRAM port timing applies to right port configured to standard SRAM mode.

ADM Port Read Cycle (Either Port Access, \overline{WE} High)

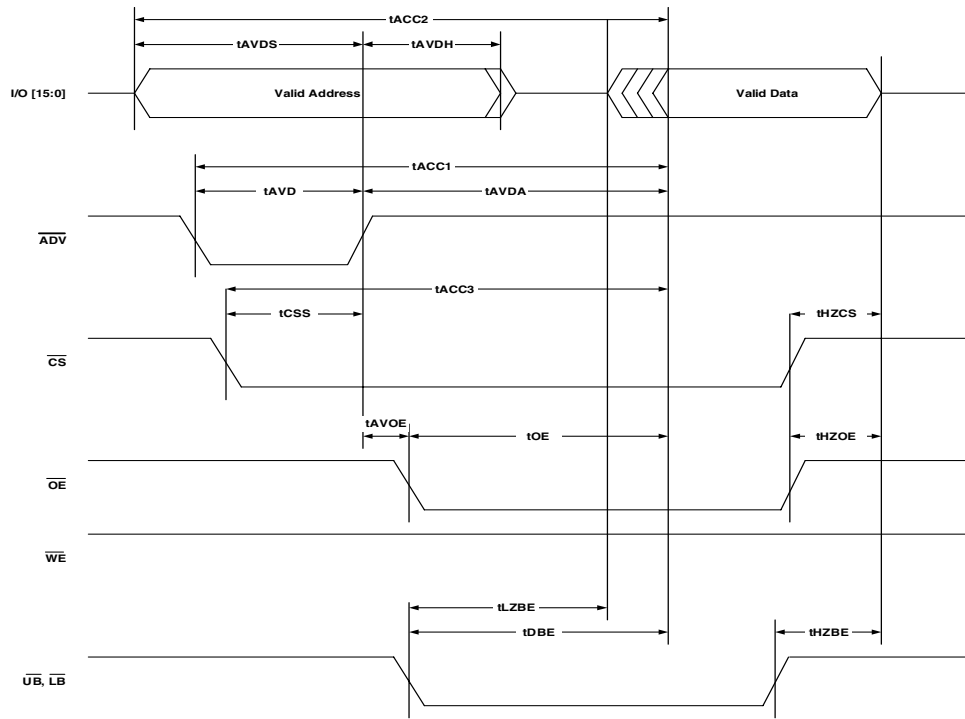

7145 drw 05

Standard Port Read Cycle (Right Port Access, \overline{WE} High)

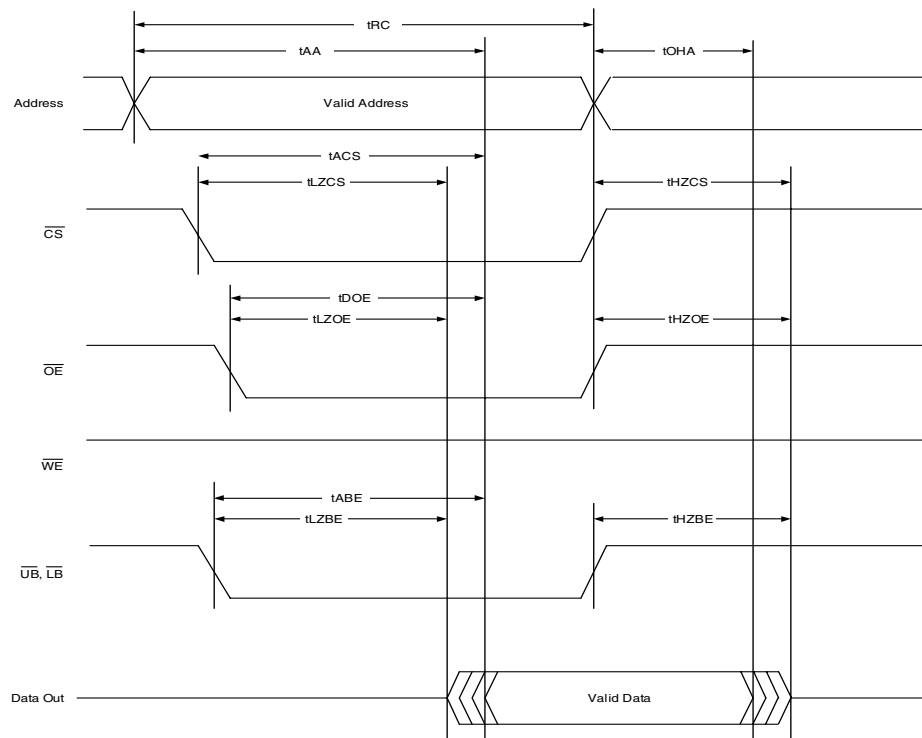

AC Electrical Characteristics Over the Operating Temperature and Supply Voltage Range⁽¹⁾

Symbol	Parameter	70P265/255/245				Unit
		65 ns		90 ns		
		Min.	Max.	Min.	Max.	
ADM Port Write Cycle⁽²⁾						
t _{WC}	Write Cycle Time	65	—	90	—	ns
t _{SCS}	\overline{CS} Low to Write End	65	—	90	—	ns
t _{AVD}	\overline{ADV} Low Pulse	7	—	20	—	ns
t _{AVDS}	Address Set-up to \overline{ADV} Rising Edge	7	—	20	—	ns
t _{AVDH}	Address Hold from \overline{ADV} Rising Edge	3	—	5	—	ns
t _{CSS}	\overline{CS} Set-up to \overline{ADV} Rising Edge	7	—	10	—	ns
t _{WRL}	\overline{WE} Pulse Width	28	—	45	—	ns
t _{BW}	$\overline{UB}/\overline{LB}$ Low to Write End	28	—	45	—	ns
t _{SD}	Data Set-up to Write End	20	—	30	—	ns
t _{HD}	Data Hold from Write End	0	—	0	—	ns
t _{LZWE} ⁽³⁾	\overline{WE} High to I/O Low-Z	0	—	0	—	ns
t _{AVWE}	\overline{ADV} High to WE Low	0	—	0	—	ns
t _{WODR}	Write End to ODR Valid	—	40	—	60	ns
Standard Port Write Cycle⁽⁴⁾						
t _{WC}	Write Cycle Time	40	—	60	—	ns
t _{SCS}	\overline{CS} Low to Write End	30	—	50	—	ns
t _{AW}	Address Valid to Write End	30	—	50	—	ns
t _{HA}	Address Hold to Write End	0	—	0	—	ns
t _{SA}	Address Set-up to Write Start	0	—	0	—	ns
t _{WRL}	Write Pulse Width	25	—	45	—	ns
t _{SD}	Data Set-up to Write End	20	—	30	—	ns
t _{HD}	Data Hold from Write End	0	—	0	—	ns
t _{H2WE} ⁽³⁾	\overline{WE} Low to Data High-Z	—	15	—	25	ns
t _{LZWE} ⁽³⁾	\overline{WE} High to Data Low-Z	0	—	0	—	ns
t _{WODR}	Write End to ODR Valid	—	40	—	60	ns

7145 tbl 13b

NOTES:

1. VDD = 1.8V
2. ADM port timing applies to left ADM port and right port configured to ADM mode.
3. This parameter is guaranteed by design and is not tested.
4. Standard SRAM port timing applies to right port configured to standard SRAM mode.

ADM Port Write Cycle (Either Port Access, \overline{WE} Controlled, \overline{OE} High)

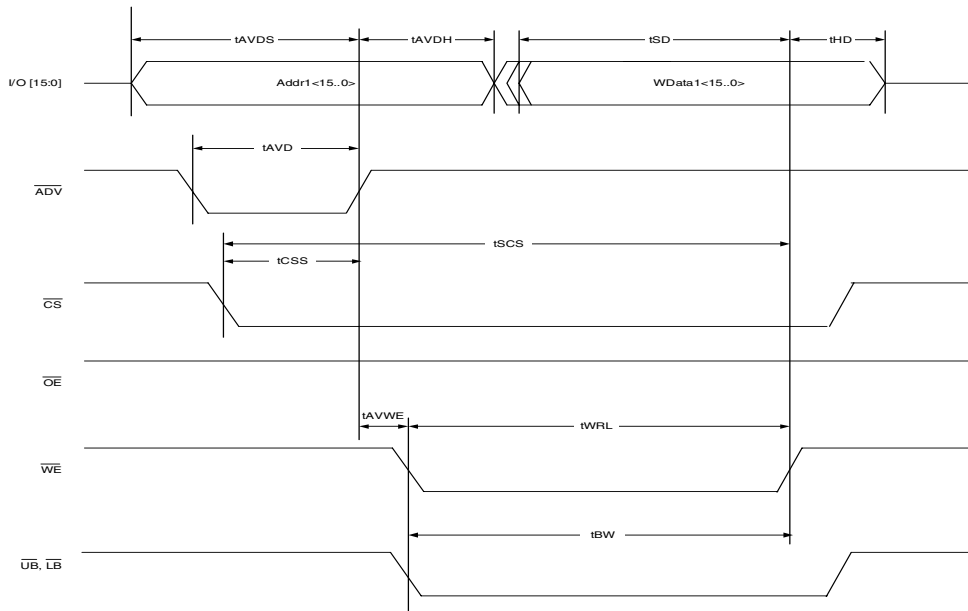

ADM Port Write Cycle (Either Port Access, \overline{CS} Controlled, \overline{OE} High)

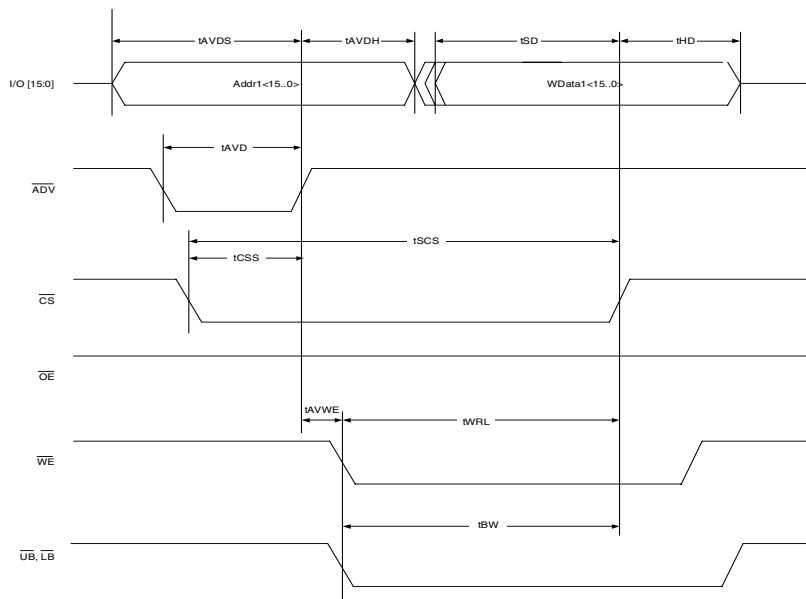

Standard Port Write Cycle (Right Port Access, \overline{WE} Controlled)

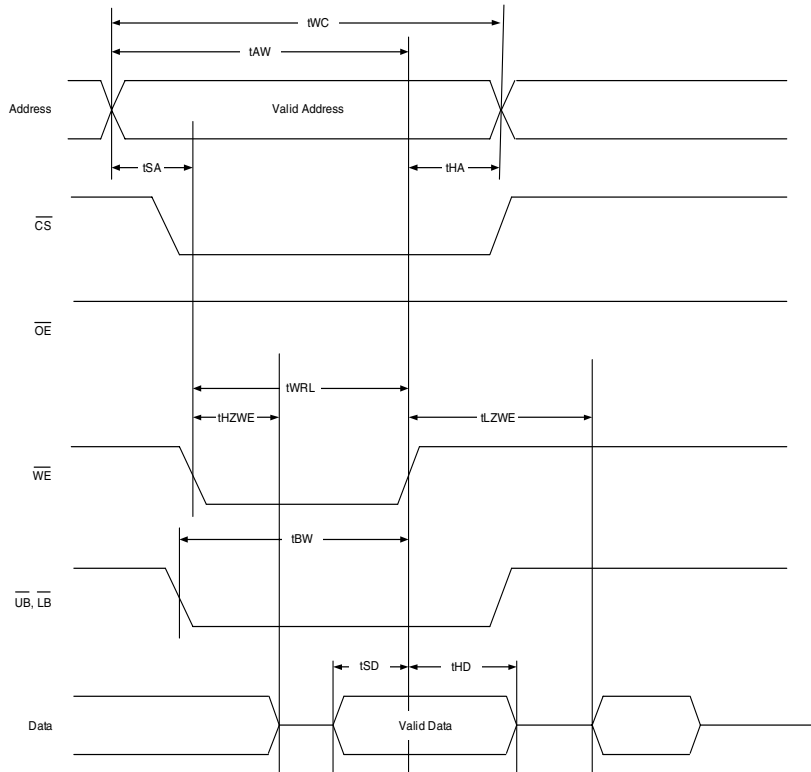

Standard Port Write Cycle (Right Port Access, \overline{CS} Controlled)

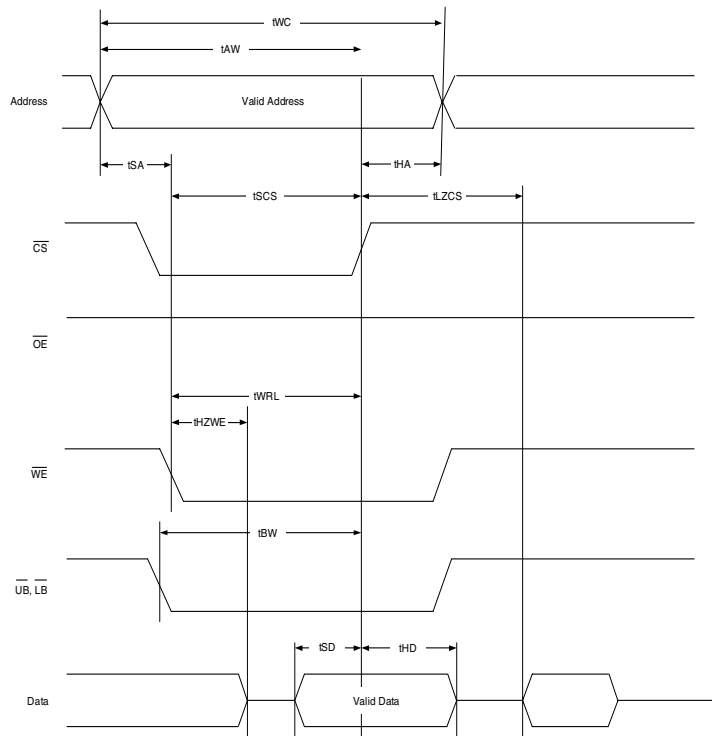

AC Electrical Characteristics Over the Operating Temperature and Supply Voltage Range⁽¹⁾

Symbol	Parameter	70P265/255/245				Unit
		65 ns		90 ns		
		Min.	Max.	Min.	Max.	
Arbitration Timing						
tBLA	$\overline{\text{BUSY}}$ Low from Address Match	—	30	—	50	ns
tBHA	$\overline{\text{BUSY}}$ High from Address Match	—	30	—	50	ns
tBLC	$\overline{\text{BUSY}}$ Low from $\overline{\text{CS}}$ Low	—	30	—	50	ns
tBHC	$\overline{\text{BUSY}}$ High from $\overline{\text{CS}}$ High	—	30	—	50	ns
tPS ⁽²⁾	Port Set-up Priority	5	—	5	—	ns
tBDD	$\overline{\text{BUSY}}$ High to Data Valid	—	30	—	50	ns
tWDD	Write Pulse to Data Delay	—	55	—	85	ns
tDDD	Write Data Valid to Read Data Valid	—	45	—	70	ns

7145 tbl 14

NOTES:

- VDD = 1.8V.
- Add 2 ns to this parameter if VDD and VDDIOH are <1.8V, and VDDIOL is >2.5V at temperature <0°C.

Arbitration Timing

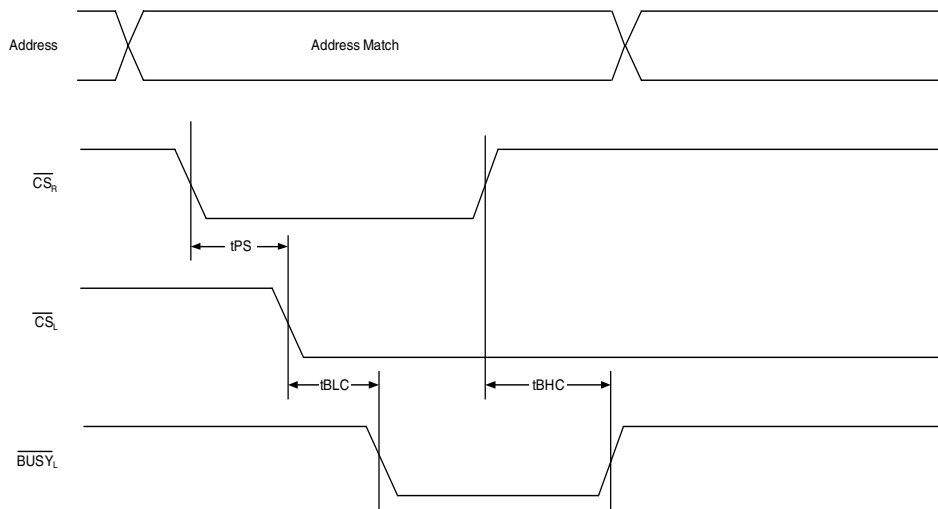

Arbitration Timing (Address Controlled with Left ADM and Right STD Configuration)

Left Address Valid First

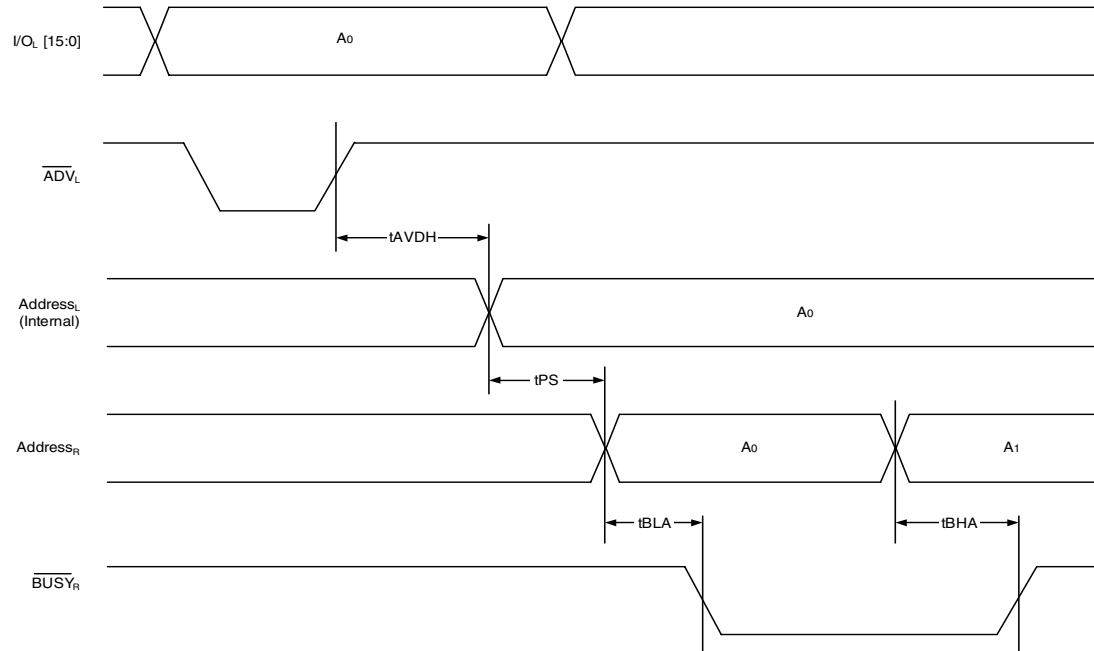

Right Address Valid First

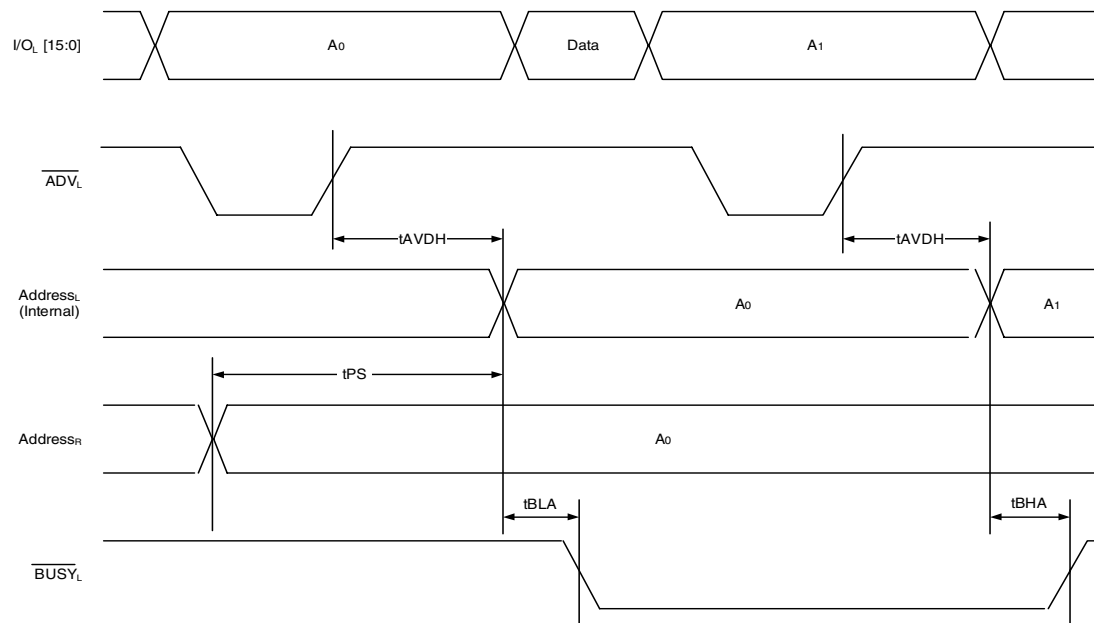

Arbitration Timing (Address Controlled with Left ADM and Right ADM Configuration)

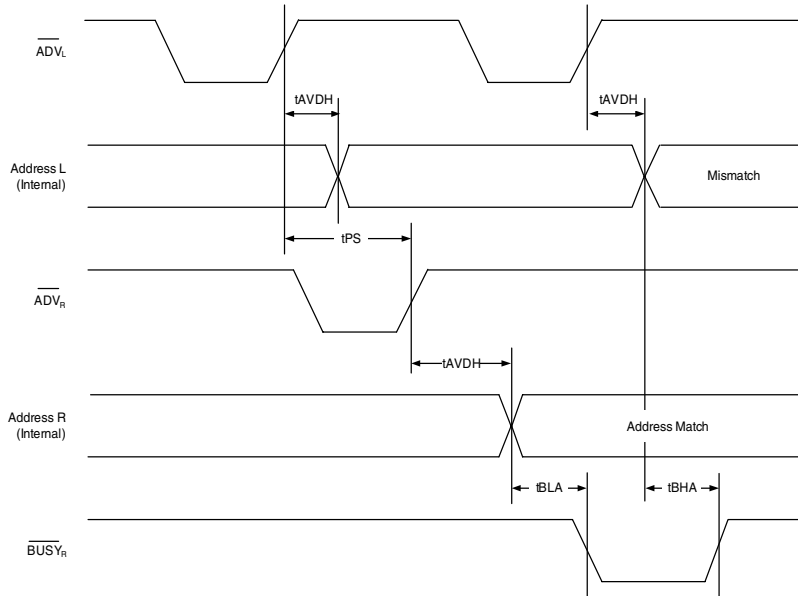

Read with BUSY Timing

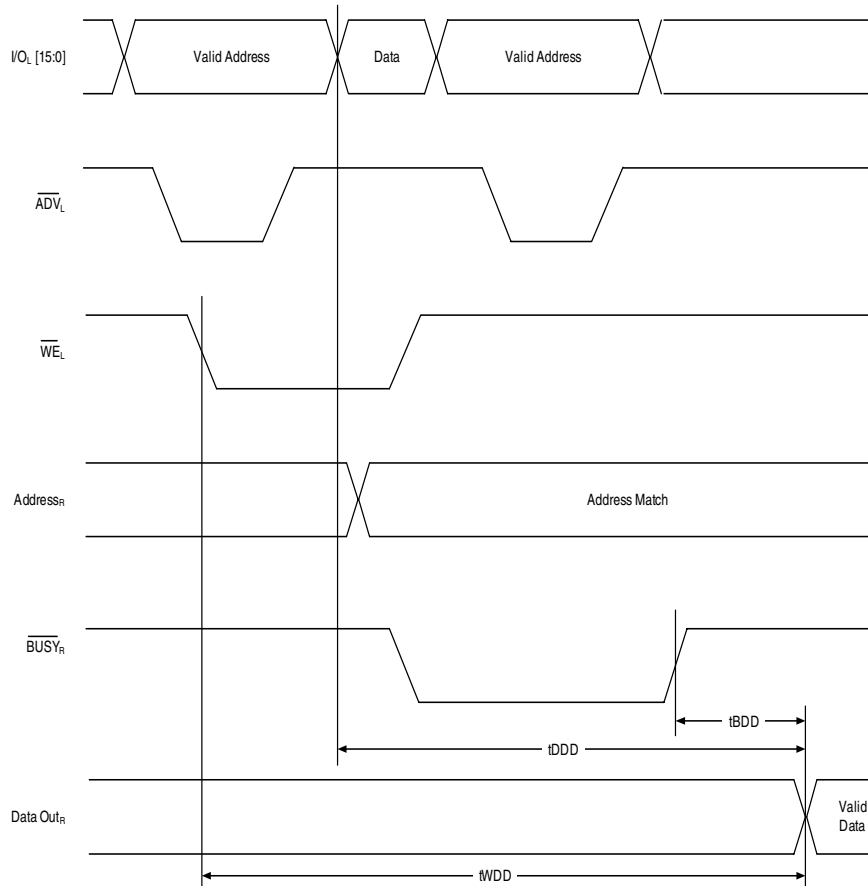

AC Electrical Characteristics Over the Operating Temperature and Supply Voltage Range⁽¹⁾

Symbol	Parameter	70P265/255/245				Unit
		65 ns		90 ns		
		Min.	Max.	Min.	Max.	
Interrupt Timing						
t _{INS}	$\overline{\text{INT}}_R$ Set Time	—	35	—	55	ns
t _{INR}	$\overline{\text{INT}}_R$ Reset Time	—	35	—	55	ns

NOTE:

1. VDD = 1.8V

7145 b1 15

Interrupt Timing

Left Port Writes to Right Mailbox Setting $\overline{\text{INT}}_R$

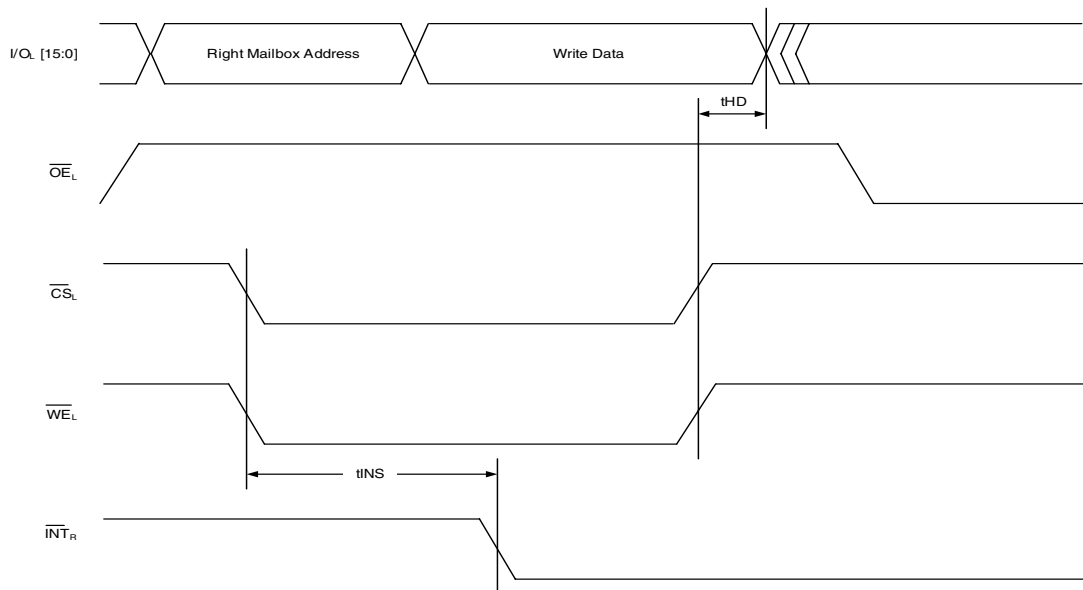

Right Port Reads Right Mailbox Clearing $\overline{\text{INT}}_R$

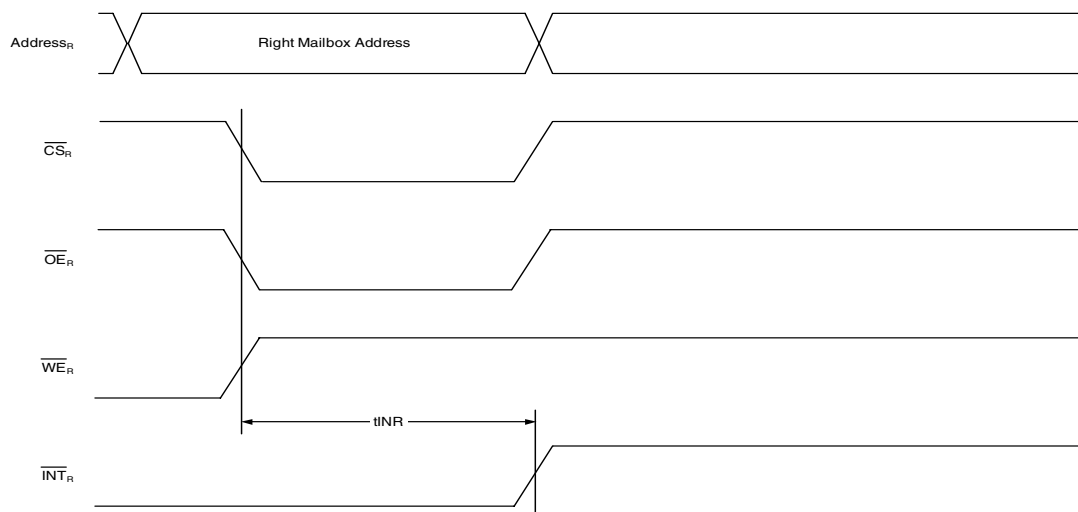

Truth Table III — Interrupt Flag⁽¹⁾

Left Port					Right Port					Function
\overline{WE}	\overline{CS}	\overline{OE}_L	A13L-A0L	\overline{INT}_L	\overline{WE}	\overline{CS}	\overline{OE}_R	A13R-A0R	\overline{INT}_R	
L	L	X	3FFF ⁽²⁾	X	X	X	X	X	L	Set Right \overline{INT}_R Flag
X	X	X	X	X	X	L	L	3FFF ⁽²⁾	H	Reset Right \overline{INT}_R Flag
X	X	X	X	L	L	L	X	3FFE ⁽³⁾	X	Set Left \overline{INT}_L Flag
X	L	L	3FFE ⁽³⁾	H	X	X	X	X	X	Reset Left \overline{INT}_L Flag

7145 tbl 16

NOTES:

1. Assumes $\overline{BUSY}_L = \overline{BUSY}_R = V_{IH}$.
2. 3FFF for 70P265, 1FFF for 70P255, FFF for 70P245.
3. 3FFE for 70P265, 1FFE for 70P255, FFE for 70P245.

Truth Table IV —
 Address BUSY Arbitration

Inputs			Outputs		Function
\overline{CS}_L	\overline{CS}_R	Address Match Left/Right Port	\overline{BUSY}_L	\overline{BUSY}_R	
X	X	NO MATCH	H	H	Normal
H	X	MATCH	H	H	Normal
X	H	MATCH	H	H	Normal
L	L	MATCH	(1)	(1)	Write Inhibit ⁽²⁾

7145 tbl 17

NOTES:

1. L if the inputs to the opposite port were stable prior to the address and enable inputs of this port. H if the inputs to the opposite port became stable after the address and enable inputs of this port. If tps is not met, either \overline{BUSY}_L or $\overline{BUSY}_R = \text{LOW}$ will result. \overline{BUSY}_L and \overline{BUSY}_R outputs cannot be LOW simultaneously.
2. Writes to the left port are internally ignored when \overline{BUSY}_L outputs are driving LOW regardless of actual logic level on the pin. Writes to the right port are internally ignored when \overline{BUSY}_R outputs are driving LOW regardless of actual logic level on the pin.

Truth Table V — Input Read Register Operation⁽³⁾

$\overline{\text{SFEN}}$	$\overline{\text{CS}}$	$\overline{\text{WE}}$	$\overline{\text{OE}}$	$\overline{\text{UB}}$	$\overline{\text{LB}}$	ADDR	I/O ₀ -I/O ₁	I/O ₂ -I/O ₁₅	Mode
H	L	H	L	L ⁽¹⁾	L ⁽¹⁾	x0000 - Max	VALID ⁽¹⁾	VALID ⁽¹⁾	Standard Memory Access
L	L	H	L	X	L	x0000	VALID ⁽²⁾	VALID ⁽⁴⁾	IRR Read ⁽³⁾

7145 tbl 18

NOTES:

- $\overline{\text{UB}}$ or $\overline{\text{LB}} = \text{V}_{\text{IL}}$. If $\overline{\text{LB}} = \text{V}_{\text{IL}}$, then I/O₀ - I/O₇ are VALID. If $\overline{\text{UB}} = \text{V}_{\text{IL}}$, then I/O₈ - I/O₁₅ are VALID.
- $\overline{\text{LB}}$ must be active ($\overline{\text{LB}} = \text{V}_{\text{IL}}$) for these bits to be valid.
- $\overline{\text{SFEN}} = \text{V}_{\text{IL}}$ to activate IRR reads.
- Valid data bits from memory.

Truth Table VI — Output Drive Register Operation⁽⁵⁾

$\overline{\text{SFEN}}$	$\overline{\text{CE}}$	R/W	$\overline{\text{OE}}$	$\overline{\text{UB}}$	$\overline{\text{LB}}$	ADDR	I/O ₀ -I/O ₄	I/O ₅ -I/O ₁₅	Mode
H	L	H	X ⁽¹⁾	L ⁽²⁾	L ⁽²⁾	x0000 - Max	VALID ⁽²⁾	VALID ⁽²⁾	Standard Memory Access
L	L	L	X	X	L	x0001	VALID ⁽³⁾	VALID ⁽⁴⁾	ODR Write ^(4,5)
L	L	H	L	X	L	x0001	VALID ⁽³⁾	VALID ⁽⁶⁾	ODR Read ⁽⁵⁾

7145 tbl 19

NOTES:

- Output enable must be low (OE = V_{IL}) during reads for valid data to be output.
- $\overline{\text{UB}}$ or $\overline{\text{LB}} = \text{V}_{\text{IL}}$. If $\overline{\text{LB}} = \text{V}_{\text{IL}}$, then I/O₀ - I/O₇ are VALID. If $\overline{\text{UB}} = \text{V}_{\text{IL}}$, then I/O₈ - I/O₁₅ are VALID.
- $\overline{\text{LB}}$ must be active ($\overline{\text{LB}} = \text{V}_{\text{IL}}$) for these bits to be valid.
- During ODR writes data will also be written to the memory.
- $\overline{\text{SFEN}} = \text{V}_{\text{IL}}$ to activate ODR reads and writes.
- Valid data bits from memory.

Functional Description

The IDT70P265/255/245 are low-power CMOS 16K/8K/4K x 16 dual-port static RAMs. The two ports are: one dedicated time-multiplexed address and data (ADM) interface and one configurable standard SRAM or ADM interface. The two ports provide separate control, address (right port only), and I/O pins that permit independent, asynchronous read and write access to any memory location. The IDT70P265/255/245 has an automatic power-down feature controlled by \overline{CS} . The \overline{CS} controls on-chip power down circuitry that permits the respective port to go into a standby mode when not selected (\overline{CS} HIGH).

Power Supply

The core voltage (V_{DD}) can be 1.8V, 2.5V or 3.0V, as long as it is lower than or equal to the I/O voltage. Each port can operate on independent I/O voltages. This is determined by what is connected to the V_{DDIOL} and V_{DDIOR} pins. The supported I/O standards are 1.8V/2.5V LVCMOS and 3.0V LVTTTL.

The IDT70P265/255/245 includes power supply isolation functionality which aids system power management. V_{DD} , V_{DDIOR} and V_{DDIOL} can all be independently powered up/down which allows either port and/or the core to be powered down when not in use. If V_{DDIOX} is powered down, but V_{DD} remains powered up all inputs to the core will be forced to deasserted states at full swing DC values to minimize leakage current and active power consumption. If V_{DD} is powered down but V_{DDIOX} remain powered up, all outputs for the port(s) in question will remain in the state they were in prior to power down.

ADM Interface Read/Write Operation

The description of this section is applicable to both the left ADM port and right port configured in ADM mode.

Three control signals, \overline{ADV} , \overline{WE} , and \overline{CS} are used to perform the read/write operation. Address signals are first applied to the I/O bus along with \overline{CS} LOW. The addresses are loaded from the I/O bus in response to the rising edge of the Address Latch Enable (\overline{ADV}) signal. It is necessary to meet the set-up (t_{AVDS}) and hold (t_{AVDH}) times given in the AC specifications with valid address information in order to properly latch the addresses.

Once the address signals are latched in, a read operation is issued when \overline{WE} stays HIGH. The I/O bus becomes HIGH-Z once the address signals meeting t_{AVDH} . The read data is driven on the I/O bus t_{OE} after the \overline{OE} is asserted LOW, and held until t_{HZOE} or t_{HZCS} after the rising edge of \overline{OE} or \overline{CS} , whichever comes first.

A write operation is issued when \overline{WE} is asserted LOW. The write data is applied to the I/O bus right after address meets the hold time (t_{AVDH}). And write data is written with the rising edge of either \overline{WE} or \overline{CS} , whichever comes first, and meets data set-up (t_{SD}) and hold (t_{HD}) times.

A write operation is issued when \overline{WE} is asserted LOW. The write data is applied to the I/O bus right after address meets the hold time (t_{AVDH}). And write data is written with the rising edge of either \overline{WE} or \overline{CS} , whichever comes first, and meets data set-up (t_{SD}) and hold (t_{HD}) times.

Standard SRAM Interface Read/Write Operation

The description of this section is applicable to the right access port configured to operate in Standard SRAM mode. Read/write operation with standard SRAM interface configuration is the same as the ADM port except addresses are presented on the address bus. Operation is controlled by \overline{CS} , \overline{OE} and \overline{WE} . A read operation is issued when \overline{WE} is asserted HIGH. A write operation is issued when \overline{WE} is asserted LOW. The I/O bus is the destination for read data and the source data for write data when the read operation is issued. However, write data needs to be driven to the I/O when the write operation is issued.

Interrupts

If the user chooses the interrupt function, a memory location (mail box or message center) is assigned to each port. The left port interrupt flag (\overline{INTL}) is asserted when the right port writes to memory location 3FFE (HEX) (1FFE for IDT70P255 and FFE for IDT70P245), where a write is defined as the $\overline{CS}=\overline{WE}=V_{IL}$ per Truth Table III. The left port clears the interrupt by accessing address location 3FFE when $\overline{CS}_R=\overline{OE}_R=V_{IL}$, \overline{WE} is a "don't care". Likewise, the right port interrupt flag (\overline{INTR}) is asserted when the left port writes to memory location 3FFF (HEX) (1FFF for IDT70P255 and FFF for IDT70P245) and to clear the interrupt flag (\overline{INTR}), the right port must read the memory location 3FFF. The message (16 bits) at 3FFE or 3FFF is user-defined, since it is an addressable SRAM location. If the interrupt function is not used, address locations 3FFE and 3FFF are not used as mail boxes, but as part of the random access memory. Refer to Truth Table III for the interrupt operation.

Busy Logic

Busy Logic provides a hardware indication that both ports of the SRAM have accessed the same location at the same time. It also allows one of the two accesses to proceed and signals the other side that the SRAM is "busy". The \overline{BUSY} pin can then be used to stall the access until the operation on the other side is completed. If a write operation has been attempted from the side that receives a \overline{BUSY} indication, the write signal is gated internally to prevent the write from proceeding.

The use of \overline{BUSY} logic is not required or desirable for all applications. In some cases it may be useful to logically OR the \overline{BUSY} outputs together and use any \overline{BUSY} indication as an interrupt source to flag the event of an illegal or illogical operation.

Input Read Register

The Input Read Register (IRR) of the IDT70P265/255/245 captures the status of two external binary input devices connected to the Input Read pins (e.g. DIP switches). The contents of the IRR are read as a standard memory access to address x0000 from either port and the data is output via the standard I/Os (Truth Table V). During Input Register reads I/O₀ - I/O₁ are valid bits and I/O₂ - I/O₁₅ are read from the memory. Writes to address x0000 are normal memory operation. When $\overline{SFEN} = V_{IH}$, the IRR is inactive and address x0000 can be used as part of the main memory. The IRR inputs will be 1.8V/2.5V LVCMOS or 3.0V LVTTTL, depending on the core voltage supply. Refer to Truth Table V for Input Read Register operation.

Output Drive Register

The Output Drive Register (ODR) of the IDT70P265/255/245 determines the state of up to five external binary-state devices by providing a path to V_{SS} for the external circuit. The five external devices supported by the ODR can operate at different voltages ($1.5V \leq V_{SUPPLY} \leq 3.5V$), but the combined current of the devices must not exceed 40mA (8mA I_{MAX} for each external device). The status of the ODR bits is set using standard write accesses from either port to address x0001 with a "1" corresponding to "on" and a "0" corresponding to "off". The status of the ODR bits can also be read (without changing the status of the bits) via a standard read to address x0001. When $\overline{SFEN} = V_{IL}$, the ODR is active and address x0001 is not available for standard memory operations. When $\overline{SFEN} = V_{IH}$, the ODR is inactive and address x0001 can be used as part of the main memory. During reads and writes to the ODR I/O₀ - I/O₄ are valid bits and I/O₅ - I/O₁₅ will not affect the ODR function but they will read from or write to the memory. Refer to Truth Table VI for Output Drive Register operation.

Ordering Information

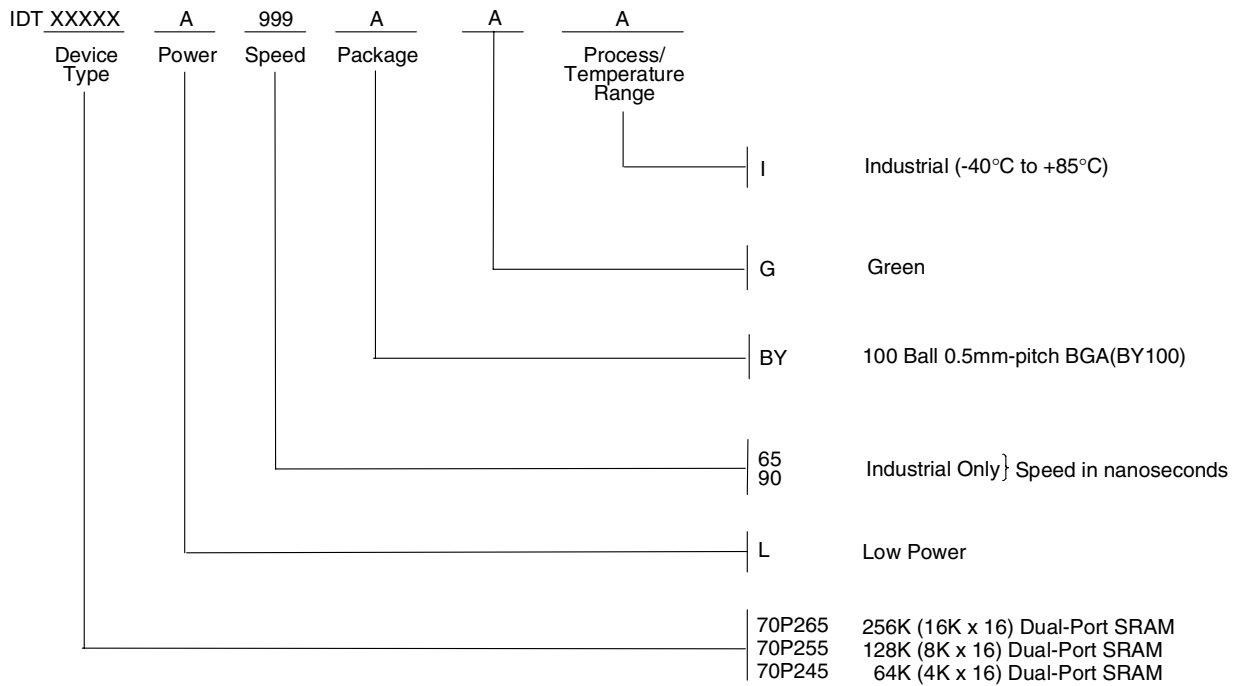

7145 drw 16

Datasheet Document History

- 10/16/08: Initial Datasheet
- 09/27/11: Changed the t_{AVD} & t_{AVDS} values each to 7ns in the ADM Port Read Cycle (page 9) and ADM Port Write Cycle (page 11) to for all three of the 70P265/255/245 devices with D/C 1137 of newer (PCN#: PA1109-01).

IMPORTANT NOTICE AND DISCLAIMER

RENESAS ELECTRONICS CORPORATION AND ITS SUBSIDIARIES (“RENESAS”) PROVIDES TECHNICAL SPECIFICATIONS AND RELIABILITY DATA (INCLUDING DATASHEETS), DESIGN RESOURCES (INCLUDING REFERENCE DESIGNS), APPLICATION OR OTHER DESIGN ADVICE, WEB TOOLS, SAFETY INFORMATION, AND OTHER RESOURCES “AS IS” AND WITH ALL FAULTS, AND DISCLAIMS ALL WARRANTIES, EXPRESS OR IMPLIED, INCLUDING, WITHOUT LIMITATION, ANY IMPLIED WARRANTIES OF MERCHANTABILITY, FITNESS FOR A PARTICULAR PURPOSE, OR NON-INFRINGEMENT OF THIRD PARTY INTELLECTUAL PROPERTY RIGHTS.

These resources are intended for developers skilled in the art designing with Renesas products. You are solely responsible for (1) selecting the appropriate products for your application, (2) designing, validating, and testing your application, and (3) ensuring your application meets applicable standards, and any other safety, security, or other requirements. These resources are subject to change without notice. Renesas grants you permission to use these resources only for development of an application that uses Renesas products. Other reproduction or use of these resources is strictly prohibited. No license is granted to any other Renesas intellectual property or to any third party intellectual property. Renesas disclaims responsibility for, and you will fully indemnify Renesas and its representatives against, any claims, damages, costs, losses, or liabilities arising out of your use of these resources. Renesas' products are provided only subject to Renesas' Terms and Conditions of Sale or other applicable terms agreed to in writing. No use of any Renesas resources expands or otherwise alters any applicable warranties or warranty disclaimers for these products.

(Disclaimer Rev.1.0 Mar 2020)

Corporate Headquarters

TOYOSU FORESIA, 3-2-24 Toyosu,
Koto-ku, Tokyo 135-0061, Japan
www.renesas.com

Contact Information

For further information on a product, technology, the most up-to-date version of a document, or your nearest sales office, please visit:
www.renesas.com/contact/

Trademarks

Renesas and the Renesas logo are trademarks of Renesas Electronics Corporation. All trademarks and registered trademarks are the property of their respective owners.