

THIS DRAWING IS UNPUBLISHED. RELEASED FOR PUBLICATION
 © COPYRIGHT BY TYCO ELECTRONICS CORPORATION. ALL INTERNATIONAL RIGHTS RESERVED.

LOC	DIST	REVISIONS					
		P	LTR	DESCRIPTION	DATE	DWN	APVD
AA	20	B		REVISED PER ECO-09-000015	9JAN2009	ZMR	WLM

- 1. MATERIAL: CARBON STEEL, 0.4[.016] THICK, BRIGHT NICKEL PLATED.
- 2. DIMENSIONS ARE MAXIMUM UNLESS OTHERWISE SPECIFIED.
- 3. CABLE RANGE: $\phi 8.89-15.88$ [.350-.625].

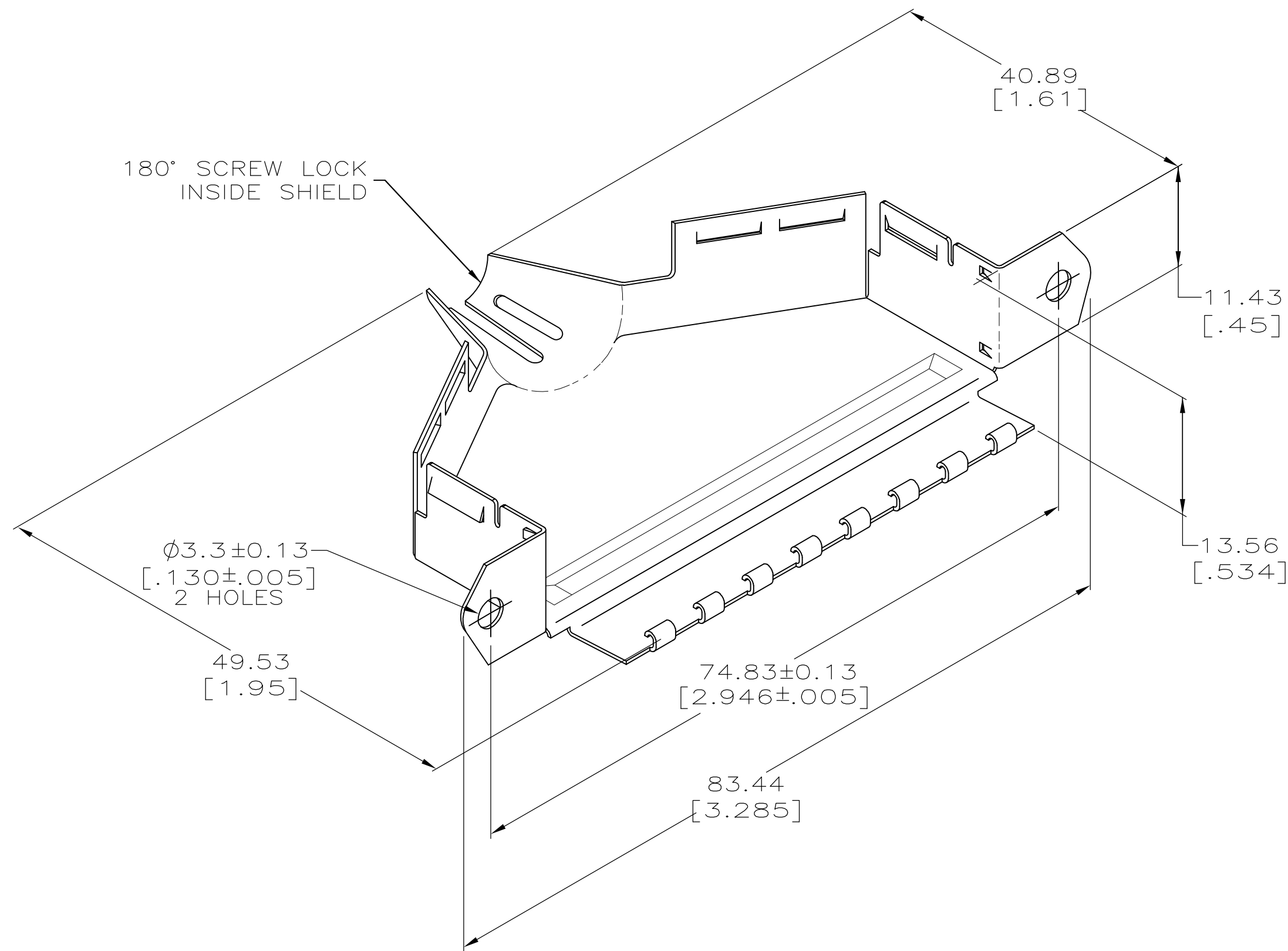

LAYER PACKED	554328-5
BULK PACKED	554328-1
PACKAGING	PART NUMBER

THIS DRAWING IS A CONTROLLED DOCUMENT.		DWN S. POZEBANCHUK 08NOV83	Tyco Electronics Corporation Harrisburg, PA 17105-3608															
DIMENSIONS: mm [INCHES]		CHK M. FRIEL 30NOV83	NAME															
TOLERANCES UNLESS OTHERWISE SPECIFIED:		APVD G. FOSTER 03JAN84	INSIDE SHIELD, 180 DEGREE, EMI, PLUG, 50 POSITION, SCREW LOCK															
<table border="0"> <tr><td>0 PLC</td><td>± -</td></tr> <tr><td>1 PLC</td><td>± -</td></tr> <tr><td>2 PLC</td><td>± -</td></tr> <tr><td>3 PLC</td><td>± -</td></tr> <tr><td>4 PLC</td><td>± -</td></tr> <tr><td>ANGLES</td><td>± -</td></tr> <tr><td>FINISH</td><td>± -</td></tr> </table>		0 PLC	± -	1 PLC	± -	2 PLC	± -	3 PLC	± -	4 PLC	± -	ANGLES	± -	FINISH	± -	PRODUCT SPEC	SIZE	RESTRICTED TO
0 PLC	± -																	
1 PLC	± -																	
2 PLC	± -																	
3 PLC	± -																	
4 PLC	± -																	
ANGLES	± -																	
FINISH	± -																	
MATERIAL	FINISH	APPLICATION SPEC	CAGE CODE	DRAWING NO														
1	1	WEIGHT	A2 00779	C=554328														
CUSTOMER DRAWING			SCALE	SHEET														
			2:1	1 of 1														
				REV B														