

FEATURES

- High-Performance Static CMOS Technology
- TMS470R1x 16/32-Bit RISC Core (ARM7TDMI™)
 - 60-MHz System Clock (Pipeline Mode)
 - Independent 16/32-Bit Instruction Set
 - Open Architecture With Third-Party Support
 - Built-In Debug Module
- Integrated Memory
 - 1M-Byte Program Flash
 - Two Banks With 16 Contiguous Sectors
 - 64K-Byte Static RAM (SRAM)
 - Memory Security Module (MSM)
 - JTAG Security Module
- Operating Features
 - Low-Power Modes: STANDBY and HALT
 - Industrial Temperature Range
- 470+ System Module
 - 32-Bit Address Space Decoding
 - Bus Supervision for Memory/Peripherals
 - Digital Watchdog (DWD) Timer
 - Analog Watchdog (AWD) Timer
 - Enhanced Real-Time Interrupt (RTI)
 - Interrupt Expansion Module (IEM)
 - System Integrity and Failure Detection
 - ICE Breaker
- Direct Memory Access (DMA) Controller
 - 32 Control Packets and 16 Channels
- Zero-Pin Phase-Locked Loop (ZPLL)-Based Clock Module With Prescaler
 - Multiply-by-4 or -8 Internal ZPLL Option
 - ZPLL Bypass Mode
- Twelve Communication Interfaces:
 - Two Serial Peripheral Interfaces (SPIs)
 - 255 Programmable Baud Rates
 - Three Serial Communication Interfaces (SCIs)
 - 2²⁴ Selectable Baud Rates
 - Asynchronous/Isosynchronous Modes
 - Two High-End CAN Controllers (HECC)
 - 32-Mailbox Capacity
 - Fully Compliant With CAN Protocol, Version 2.0B
 - Five Inter-Integrated Circuit (I2C) Modules
 - Multi-Master and Slave Interfaces
 - Up to 400 Kbps (Fast Mode)
 - 7- and 10-Bit Address Capability
- High-End Timer Lite (HET)
 - 12 Programmable I/O Channels:
 - 12 High-Resolution Pins
 - High-Resolution Share Feature (XOR)
 - High-End Timer RAM
 - 64-Instruction Capacity
- External Clock Prescale (ECP) Module
 - Programmable Low-Frequency External Clock (CLK)
- 12-Channel, 10-Bit Multi-Buffered ADC (MibADC)
 - 64-Word FIFO Buffer
 - Single- or Continuous-Conversion Modes
 - 1.55 μs Minimum Sample and Conversion Time
 - Calibration Mode and Self-Test Features
- Flexible Interrupt Handling
- Expansion Bus Module (EBM)
 - Supports 8- and 16-Bit Expansion Bus Memory Interface Mappings
 - 42 I/O Expansion Bus Pins
- 46 Dedicated General-Purpose I/O (GIO) Pins and 47 Additional Peripheral I/Os
- Sixteen External Interrupts
- On-Chip Scan-Base Emulation Logic, IEEE Standard 1149.1⁽¹⁾ (JTAG) Test-Access Port



Please be aware that an important notice concerning availability, standard warranty, and use in critical applications of Texas Instruments semiconductor products and disclaimers thereto appears at the end of this data sheet.

ARM7TDMI is a trademark of Advanced RISC Machines Limited (ARM).
All other trademarks are the property of their respective owners.

TMS470R1B1M

16/32-Bit RISC Flash Microcontroller

SPNS109A—SEPTEMBER 2005—REVISED AUGUST 2006

- 144-Pin Plastic Low-Profile Quad Flatpack (PGE Suffix)

(1) The test-access port is compatible with the IEEE Standard 1149.1-1990, IEEE Standard Test-Access Port and Boundary Scan Architecture specification. Boundary scan is not supported on this device.

TMS470R1B1M 144-Pin PGE Package Without Expansion Bus (Top View)

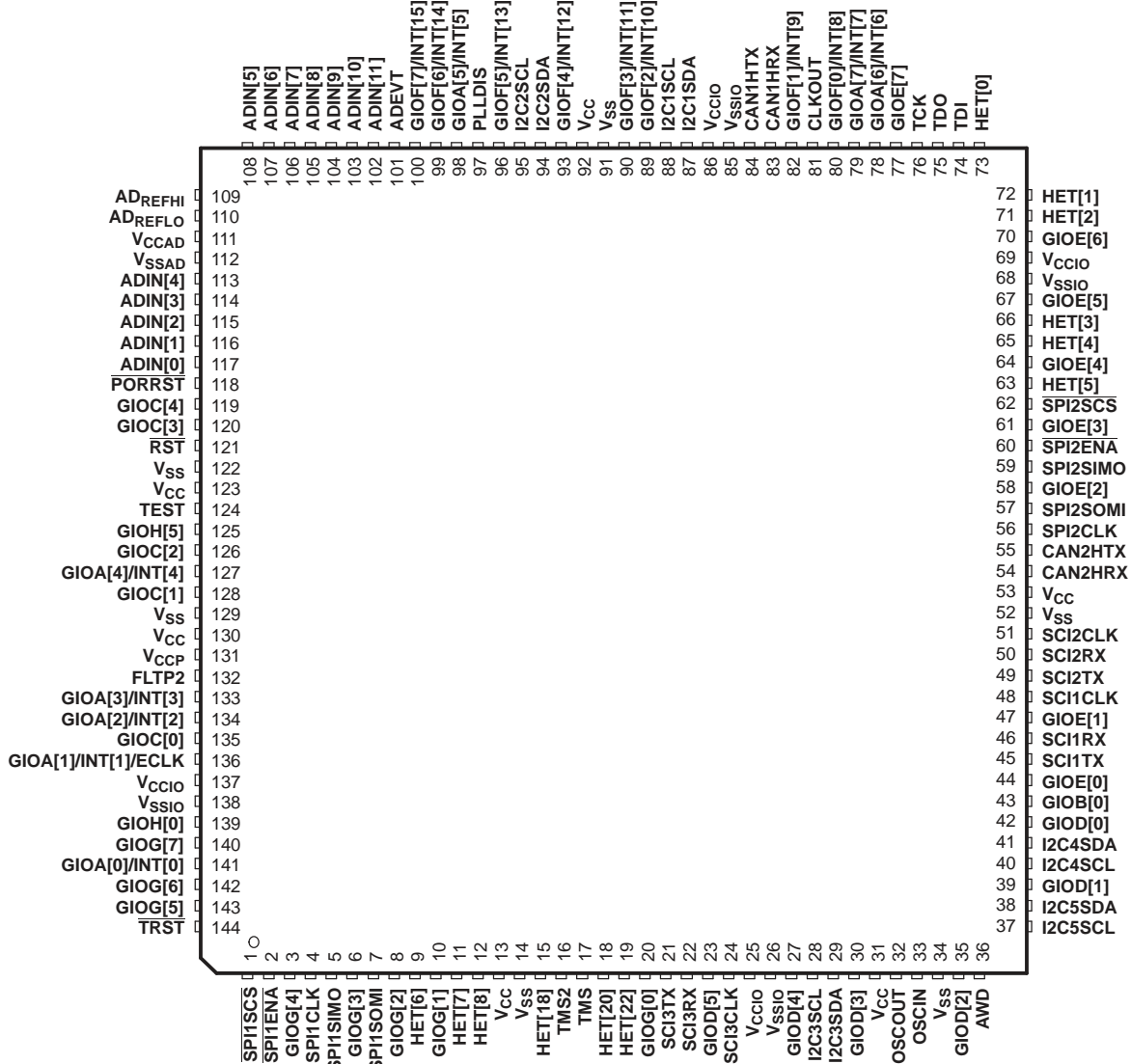

TMS470R1B1M 144-Pin PGE Package With Expansion Bus (Top View)

ADREFHI	109	ADIN[5]	108	SPI1SCS	1	HET[0]	73
ADREFLO	110	ADIN[6]	107	SPI1ENA	2	HET[1]	72
VCCAD	111	ADIN[7]	106	EBADDR[18]/EBADDR[10]	3	HET[2]	71
VSSAD	112	ADIN[8]	105	SPI1CLK	4	EBDATA[6]	70
ADIN[4]	113	ADIN[9]	104	SPI1SIMO	5	VCCIO	69
ADIN[3]	114	ADIN[10]	103	SPI1SOMI	6	VSSIO	68
ADIN[2]	115	ADIN[11]	102	EBADDR[17]/EBADDR[9]	7	EBDATA[5]	67
ADIN[1]	116	ADEVT	101	EBADDR[16]/EBADDR[8]	8	HET[3]	66
ADIN[0]	117	EBADDR[13]/EBDATA[15]	100	HET[6]	9	HET[4]	65
PORRST	118	EBADDR[12]/EBDATA[14]	99	HET[7]	10	EBDATA[4]	64
EBCS[6]	119	GIOA[5]/INT[5]	98	HET[8]	11	HET[5]	63
EBCS[5]	120	PLLDIS	97	VCC	12	SPI2SCS	62
RST	121	EBADDR[11]/EBDATA[13]	96	VSS	13	EBDATA[3]	61
VSS	122	I2C2SCL	95	HET[18]	14	SPI2ENA	60
VCC	123	I2C2SDA	94	TMS2	15	SPI2SIMO	59
TEST	124	EBADDR[10]/EBDATA[12]	93	TMS	16	EBDATA[2]	58
EBHOLD	125	VCC	92	HET[20]	17	SPI2SOMI	57
EBWR[1]	126	VSS	91	HET[21]	18	SPI2CLK	56
GIOA[4]/INT[4]	127	I2C1SCL	90	HET[22]	19	CAN2HTX	55
EBWR[0]	128	I2C1SDA	89	EBADDR[14]/EBADDR[6]	20	CAN2HRX	54
VSS	129	VCC	88	SCI3TX	21	VCC	53
VCC	130	VSS	87	SCI3CLK	22	VSS	52
VCCP	131	EBADDR[9]/EBDATA[11]	86	SCI8RX	23	SCI2CLK	51
FLTP2	132	EBADDR[8]/EBDATA[10]	85	EBADDR[5]	24	SCI2RX	50
GIOA[3]/INT[3]	133	I2C1SCL	84	VCCIO	25	SCI2TX	49
GIOA[2]/INT[2]	134	I2C3SCL	83	VSSIO	26	SCI1CLK	48
EBOE	135	I2C3SDA	82	EBADDR[4]	27	EBDATA[1]	47
GIOA[1]/INT[1]/ECLK	136	EBADDR[7]/EBDATA[9]	81	I2C3SCL	28	SCI1RX	46
VCCIO	137	CLKOUT	80	I2C3SDA	29	SCI1TX	45
VSSIO	138	EBADDR[6]/EBDATA[8]	79	EBADDR[3]	30	EBDATA[0]	44
EBADDR[22]/EBADDR[14]	139	GIOA[6]/INT[6]	78	VCC	31	EBDMAREQ[0]	43
EBADDR[21]/EBADDR[13]	140	EBDATA[7]	77	OSCOUT	32	EBADDR[0]	42
GIOA[0]/INT[0]	141	TCK	76	OSCIN	33	EBADDR[23]/EBADDR[15]	41
EBADDR[20]/EBADDR[12]	142	TDO	75	VSS	34	EBADDR[24]/EBADDR[16]	40
EBADDR[19]/EBADDR[11]	143	TDI	74	EBADDR[2]	35	EBADDR[1]	39
TRST	144	HET[0]	73	AWD	36	EBADDR[26]/EBADDR[18]	38
						EBADDR[25]/EBADDR[17]	37

DESCRIPTION

The TMS470R1B1M⁽¹⁾ devices are members of the Texas Instruments TMS470R1x family of general-purpose 16/32-bit reduced instruction set computer (RISC) microcontrollers. The B1M microcontroller offers high performance utilizing the high-speed ARM7TDMI 16/32-bit RISC central processing unit (CPU), resulting in a high instruction throughput while maintaining greater code efficiency. The ARM7TDMI 16/32-bit RISC CPU views memory as a linear collection of bytes numbered upwards from zero. The TMS470R1B1M utilizes the big-endian format where the most significant byte of a word is stored at the lowest numbered byte and the least significant byte at the highest numbered byte.

High-end embedded control applications demand more performance from their controllers while maintaining low costs. The B1M RISC core architecture offers solutions to these performance and cost demands while maintaining low power consumption.

The B1M devices contain the following:

- ARM7TDMI 16/32-Bit RISC CPU
- TMS470R1x system module (SYS) with 470+ enhancements
- 1M-byte flash
- 64K-byte SRAM
- Zero-pin phase-locked loop (ZPLL) clock module
- Digital watchdog (DWD) timer
- Analog watchdog (AWD) timer
- Enhanced real-time interrupt (RTI) module
- Interrupt expansion module (IEM)
- Memory security module (MSM)
- JTAG security module
- Two serial peripheral interface (SPI) modules
- Three serial communications interface (SCI) modules
- Two high-end CAN controllers (HECC)
- Five inter-integrated circuit (I2C) modules
- 10-bit multi-buffered analog-to-digital converter (MibADC), with 12 input channels
- High-end timer lite (HET) controlling 12 I/Os
- External clock prescale (ECP)
- Expansion bus module (EBM)
- Up to 93 I/O pins

The functions performed by the 470+ system module (SYS) include:

- Address decoding
- Memory protection
- Memory and peripherals bus supervision
- Reset and abort exception management
- Prioritization for all internal interrupt sources
- Device clock control
- Parallel signature analysis (PSA)

The enhanced real-time interrupt (RTI) module on the B1M has the option to be driven by the oscillator clock. The digital watchdog (DWD) is a 25-bit resettable decrementing counter that provides a system reset when the watchdog counter expires. This data sheet includes device-specific information such as memory and peripheral select assignment, interrupt priority, and a device memory map. For a more detailed functional description of the SYS module, see the *TMS470R1x System Module Reference Guide* (literature number SPNU189).

The B1M memory includes general-purpose SRAM supporting single-cycle read/write accesses in byte, half-word, and word modes.

(1) Throughout the remainder of this document, the TMS470R1B1M will be referred to as either the full device name or as B1M.

The flash memory on this device is a nonvolatile, electrically erasable and programmable memory implemented with a 32-bit-wide data bus interface. The flash operates with a system clock frequency of up to 24 MHz or 30 MHz, depending on the input voltage. When in pipeline mode, the flash operates with a system clock frequency of up to 48 MHz or 60 MHz, depending on the input voltage. For more detailed information on the flash, see the *F05 Flash* section of this data sheet.

The memory security module (MSM) and the JTAG security module prevent unauthorized access and visibility to on-chip memory, thereby preventing reverse engineering or manipulation of proprietary code.

The B1M device has twelve communication interfaces: two SPIs, three SCIs, two HECCs, and five I2Cs. The SPI provides a convenient method of serial interaction for high-speed communications between similar shift-register type devices. The SCI is a full-duplex, serial I/O interface intended for asynchronous communication between the CPU and other peripherals using the standard non-return-to-zero (NRZ) format. The HECC uses a serial, multimaster communication protocol that efficiently supports distributed real-time control with robust communication rates of up to 1 megabit per second (Mbps). These CAN peripherals are ideal for applications operating in noisy and harsh environments (e.g., industrial fields) that require reliable serial communication or multiplexed wiring. The I2C module is a multi-master communication module providing an interface between the B1M microcontroller and an I2C-compatible device via the I2C serial bus. The I2C supports both 100 Kbps and 400 Kbps speeds. For more detailed functional information on the SPI, SCI, and CAN peripherals, see the specific reference guides (literature numbers SPNU195, SPNU196, and SPNU197). For more detailed functional information on the I2C, see the *TMS470R1x Inter-Integrated Circuit (I2C) Reference Guide* (literature number SPNU223).

The HET is an advanced intelligent timer that provides sophisticated timing functions for real-time applications. The timer is software-controlled, using a reduced instruction set, with a specialized timer micromachine and an attached I/O port. The HET can be used for compare, capture, or general-purpose I/O. It is especially well suited for applications requiring multiple sensor information and drive actuators with complex and accurate time pulses. The HET used in this device is the high-end timer lite. It has fewer I/Os than the usual 32 in a standard HET. For more detailed functional information on the HET, see the *TMS470R1x High-End Timer (HET) Reference Guide* (literature number SPNU199).

The B1M HET peripheral contains the XOR-share feature. This feature allows two adjacent HET high-resolution channels to be XORed together, making it possible to output smaller pulses than a standard HET. For more detailed information on the HET XOR-share feature, see the *TMS470R1x High-End Timer (HET) Reference Guide* (literature number SPNU199).

The B1M device has one 10-bit-resolution, sample-and-hold MibADC. Each of the MibADC channels can be converted individually or can be grouped by software for sequential conversion sequences. There are three separate groupings, two of which can be triggered by an external event. Each sequence can be converted once when triggered or configured for continuous conversion mode. For more detailed functional information on the MibADC, see the *TMS470R1x Multi-Buffered Analog-to-Digital Converter (MibADC) Reference Guide* (literature number SPNU206).

The zero-pin phase-locked loop (ZPLL) clock module contains a phase-locked loop, a clock-monitor circuit, a clock-enable circuit, and a prescaler (with prescale values of 1–8). The function of the ZPLL is to multiply the external frequency reference to a higher frequency for internal use. The ZPLL provides ACLK to the system (SYS) module. The SYS module subsequently provides system clock (SYSCLK), real-time interrupt clock (RTICK), CPU clock (MCLK), and peripheral interface clock (ICLK) to all other B1M device modules. For more detailed functional information on the ZPLL, see the *TMS470R1x Zero-Pin Phase-Locked Loop (ZPLL) Clock Module Reference Guide* (literature number SPNU212).

NOTE:

ACLK should not be confused with the MibADC internal clock, ADCLK. ACLK is the continuous system clock from an external resonator/crystal reference.

The expansion bus module (EBM) is a standalone module that supports the multiplexing of the GIO functions and the expansion bus interface. For more information on the EBM, see the *TMS470R1x Expansion Bus Module (EBM) Reference Guide* (literature number SPNU222).

TMS470R1B1M

16/32-Bit RISC Flash Microcontroller

SPNS109A–SEPTEMBER 2005–REVISED AUGUST 2006

The B1M device also has an external clock prescaler (ECP) module that when enabled, outputs a continuous external clock (ECLK) on a specified GIO pin. The ECLK frequency is a user-programmable ratio of the peripheral interface clock (ICLK) frequency. For more detailed functional information on the ECP, see the *TMS470R1x External Clock Prescaler (ECP) Reference Guide* (literature number SPNU202).

Device Characteristics

Table 1 identifies all the characteristics of the B1M device except the SYSTEM and CPU, which are generic.

Table 1. Device Characteristics

CHARACTERISTICS	DEVICE DESCRIPTION TMS470R1B1M	COMMENTS
MEMORY		
For the number of memory selects on this device, see Table 3 , <i>TMS470R1B1M Memory Selection Assignment</i> .		
INTERNAL MEMORY	Pipeline/Non-Pipeline 1M-Byte flash 64K-Byte SRAM Memory Security Module (MSM) JTAG Security Module	Flash is pipeline-capable. The B1M RAM is implemented in one 64K array selected by two memory-select signals (see Table 3 , <i>TMS470R1B1M Memory Selection Assignment</i>).
PERIPHERALS		
For the device-specific interrupt priority configurations, see Table 6 , <i>Interrupt Priority</i> . And for the 1K peripheral address ranges and their peripheral selects, see Table 4 , <i>B1M Peripherals, System Module, and Flash Base Addresses</i> .		
CLOCK	ZPLL	Zero-pin PLL has no external loop filter pins.
Expansion Bus	EBM	Expansion bus module with 42 pins. Supports 8- and 16-bit memories. See Table 7 for details.
GENERAL-PURPOSE I/Os	46 I/O	Port A has 8 external pins; Port B has only 1 external pin; Port C has 5 external pins; Port D has 6 external pins; Ports E, F, and G each have 8 external pins; and Port H has 2 external pins.
ECP	YES	
SCI	3 (3-pin)	
CAN (HECC and/or SCC)	2 HECC	Two high-end CAN controllers
SPI (5-pin, 4-pin or 3-pin)	2 (5-pin)	
I2C	5	
HET with XOR Share	12 I/O	The high-resolution (HR) SHARE feature allows even-numbered HR pins to share the next higher odd-numbered HR pin structures. This HR sharing is independent of whether or not the odd pin is available externally. If an odd pin is available externally and <i>shared</i> , then the odd pin can only be used as a general-purpose I/O. For more information on HR SHARE, see the <i>TMS470R1x High-End Timer (HET) Reference Guide</i> (literature number SPNU199).
HET RAM	64-Instruction Capacity	
MibADC	10-bit, 12-channel 64-word FIFO	Both the logic and registers for a full 16-channel MibADC are present.
CORE VOLTAGE	1.8 V	
I/O VOLTAGE	3.3 V	
PINS	144	
PACKAGES	PGE	

Functional Block Diagram

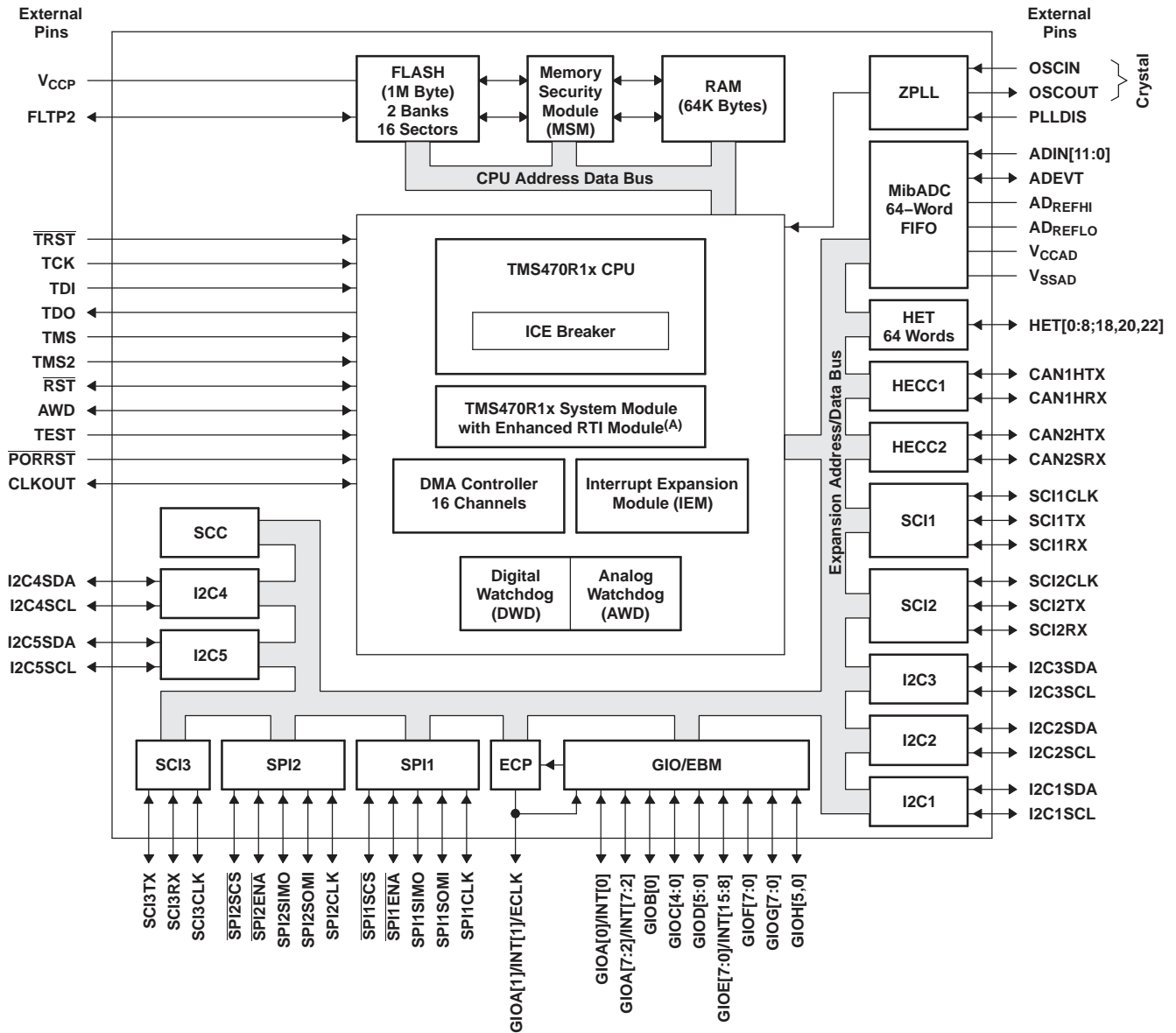

A. The enhanced RTI module is the system module with two extra bits to disable the ZPLL while in STANDBY mode.

Table 2. Terminal Functions

TERMINAL		TYPE ⁽¹⁾⁽²⁾	CURRENT OUTPUT	INTERNAL PULLUP/PULLDOWN ⁽³⁾	DESCRIPTION
NAME	NO.				
HIGH-END TIMER (HET)					
HET[0]	73	3.3 V	2 mA -z	IPD (20 µA)	<p>Timer input capture or output compare. The HET[8:0,18,20,22] applicable pins can be programmed as general-purpose input/output (GIO) pins. All are high-resolution pins.</p> <p>The high-resolution (HR) SHARE feature allows even HR pins to share the next higher odd HR pin structures. This HR sharing is independent of whether or not the odd pin is available externally. If an odd pin is available externally and shared, then the odd pin can only be used as a general-purpose I/O. For more information on HR SHARE, see the <i>TMS470R1x High-End Timer (HET) Reference Guide</i> (literature number SPNU199).</p>
HET[1]	72				
HET[2]	71				
HET[3]	66				
HET[4]	65				
HET[5]	63				
HET[6]	9				
HET[7]	11				
HET[8]	12				
HET[18]	15				
HET[20]	18				
HET[22]	19				
HIGH-END CAN CONTROLLER (HECC)					
CAN1HRX	83	5-V tolerant	4 mA		HECC1 receive pin or GIO pin
CAN1HTX	84	3.3 V	2 mA -z	IPU (20 µA)	HECC1 transmit pin or GIO pin
CAN2HRX	54	5-V tolerant	4 mA		HECC2 receive pin or GIO pin
CAN2HTX	55	3.3 V	2 mA -z	IPU (20 µA)	HECC2 transmit pin or GIO pin
STANDARD CAN CONTROLLER (SCC)					
CANSRX	-	5-V tolerant	4 mA		SCC receive pin. The CANSRX signal is only connected to the pad and not to a package pin. For reduced power consumption in low power mode, CANSRX should be driven output LOW.
CANSTX	-	3.3 V	2 mA -z	IPU (20 µA)	SCC transmit pin. The CANSTX signal is only connected to the pad and not to a package pin. For reduced power consumption in low power mode, CANSTX should be driven output LOW.
GENERAL-PURPOSE I/O (GIO)					
GIOA[0]/INT[0]	141	5-V tolerant	4 mA		<p>General-purpose input/output pins. GIOA[7:0]/INT[7:0] are interrupt-capable pins.</p> <p>GIOA[1]/INT[1]/ECLK pin is multiplexed with the external clock-out function of the external clock prescale (ECP) module.</p>
GIOA[1]/INT[1]/ECLK	136				
GIOA[2]/INT[2]	134				
GIOA[3]/INT[3]	133				
GIOA[4]/INT[4]	127				
GIOA[5]/INT[5]	98				
GIOA[6]/INT[6]	78				
GIOA[7]/INT[7]	79				
GIOB[0]/EBDMAREQ0	43	3.3 V	2 mA -z	IPD (20 µA)	<p>GIOB[0], GIOC[4:0], GIOD[5:0], GIOE[7:0:], GIOF[7:0:], GIOG[7:0:], and GIOH[5,0] are multiplexed with the expansion bus module.</p> <p>See Table 7.</p>
GIOC[0]/EBOE	135				
GIOC[1]/EBWR[0]	128				
GIOC[2]/EBWR[1]	126				
GIOC[3]/EBCS[5]	120				
GIOC[4]/EBCS[6]	119				

(1) PWR = power, GND = ground, REF = reference voltage, NC = no connect

(2) All I/O pins, except RST, are configured as inputs while PORRST is low and immediately after PORRST goes high.

(3) IPD = internal pulldown, IPU = internal pullup (all internal pullups and pulldowns are active on input pins, independent of the PORRST state.)

Table 2. Terminal Functions (continued)

TERMINAL		TYPE ⁽¹⁾⁽²⁾	CURRENT OUTPUT	INTERNAL PULLUP/PULLDOWN ⁽³⁾	DESCRIPTION
NAME	NO.				
GIOD[0]/EBADDR[0]	42	3.3 V	2 mA -z	IPD (20 µA)	GIOB[0], GIOC[4:0], GIOD[5:0], GIOE[7:0:], GIOF[7:0], GIOG[7:0], and GIOH[5,0] are multiplexed with the expansion bus module. GIOF[7:0]/INT[15:8] are interrupt-capable pins. See Table 7 .
GIOD[1]/EBADDR[1]	39				
GIOD[2]/EBADDR[2]	35				
GIOD[3]/EBADDR[3]	30				
GIOD[4]/EBADDR[4]	27				
GIOD[5]/EBADDR[5]	23				
GIOE[0]/EBDATA[0]	44				
GIOE[1]/EBDATA[1]	47				
GIOE[2]/EBDATA[2]	58				
GIOE[3]/EBDATA[3]	61				
GIOE[4]/EBDATA[4]	64				
GIOE[5]/EBDATA[5]	67				
GIOE[6]/EBDATA[6]	70				
GIOE[7]/EBDATA[7]	77				
GIOF[0]/INT[8]/EBADDR[6]/EBDATA[8]	80				
GIOF[1]/INT[9]/EBADDR[7]/EBDATA[9]	82				
GIOF[2]/INT[10]/EBADDR[8]/EBDATA[10]	89				
GIOF[3]/INT[11]/EBADDR[9]/EBDATA[11]	90				
GIOF[4]/INT[12]/EBADDR[10]/EBDATA[12]	93				
GIOF[5]/INT[13]/EBADDR[11]/EBDATA[13]	96				
GIOF[6]/INT[14]/EBADDR[12]/EBDATA[14]	99				
GIOF[7]/INT[15]/EBADDR[13]/EBDATA[15]	100				
GIOG[0]/EBADDR[14]/EBADDR[6]	20				
GIOG[1]/EBADDR[15]/EBADDR[7]	10				
GIOG[2]/EBADDR[16]/EBADDR[8]	8				
GIOG[3]/EBADDR[17]/EBADDR[9]	6				
GIOG[4]/EBADDR[18]/EBADDR[10]	3				
GIOG[5]/EBADDR[19]/EBADDR[11]	143				
GIOG[6]/EBADDR[20]/EBADDR[12]	142				
GIOG[7]/EBADDR[21]/EBADDR[13]	140				
GIOH[0]/EBADDR[22]/EBADDR[14]	139				
GIOH[5]/EBHOLD	125				

Table 2. Terminal Functions (continued)

TERMINAL		TYPE ⁽¹⁾⁽²⁾	CURRENT OUTPUT	INTERNAL PULLUP/PULLDOWN ⁽³⁾	DESCRIPTION	
NAME	NO.					
MULTI-BUFFERED ANALOG-TO-DIGITAL CONVERTER (MibADC)						
ADEVT	101	3.3 V	2 mA -z	IPD (20 µA)	MibADC event input. Can be programmed as a GIO pin.	
ADIN[0]	117		MibADC analog input pins			
ADIN[1]	116					
ADIN[2]	115					
ADIN[3]	114					
ADIN[4]	113					
ADIN[5]	108					
ADIN[6]	107					
ADIN[7]	106					
ADIN[8]	105					
ADIN[9]	104					
ADIN[10]	103					
ADIN[11]	102					
AD _{REFHI}	109	3.3 VREF				MibADC module high-voltage reference input
AD _{REFLO}	110	GND REF			MibADC module low-voltage reference input	
V _{CCAD}	111	3.3-V PWR			MibADC analog supply voltage	
V _{SSAD}	112	GND			MibADC analog ground reference	
SERIAL PERIPHERAL INTERFACE 1 (SPI1)						
SPI1CLK	4	5-V tolerant	4 mA		SPI1 clock. SPI1CLK can be programmed as a GIO pin.	
SPI1EN \bar{A}	2				SPI1 chip enable. Can be programmed as a GIO pin.	
SPI1SC \bar{S}	1				SPI1 slave chip select. Can be programmed as a GIO pin.	
SPI1SIMO	5				SPI1 data stream. Slave in/master out. Can be programmed as a GIO pin.	
SPI1SOMI	7				SPI1 data stream. Slave out/master in. Can be programmed as a GIO pin.	
SERIAL PERIPHERAL INTERFACE 2 (SPI2)						
SPI2CLK	56	5-V tolerant	4 mA		SPI2 clock. Can be programmed as a GIO pin.	
SPI2EN \bar{A}	60				SPI2 chip enable. Can be programmed as a GIO pin.	
SPI2SC \bar{S}	62				SPI2 slave chip select. Can be programmed as a GIO pin.	
SPI2SIMO	59				SPI2 data stream. Slave in/master out. Can be programmed as a GIO pin.	
SPI2SOMI	57				SPI2 data stream. Slave out/master in. Can be programmed as a GIO pin.	
INTER-INTEGRATED CIRCUIT 1 (I2C1)						
I2C1SDA	87	5-V tolerant	4 mA		I2C1 serial data pin or GIO pin	
I2C1SCL	88				I2C1 serial clock pin or GIO pin	
INTER-INTEGRATED CIRCUIT 2 (I2C2)						
I2C2SDA	94	5-V tolerant	4 mA		I2C2 serial data pin or GIO pin	
I2C2SCL	95				I2C2 serial clock pin or GIO pin	

Table 2. Terminal Functions (continued)

TERMINAL		TYPE ⁽¹⁾⁽²⁾	CURRENT OUTPUT	INTERNAL PULLUP/PULLDOWN ⁽³⁾	DESCRIPTION
NAME	NO.				
INTER-INTEGRATED CIRCUIT 3 (I2C3)					
I2C3SDA	29	5-V tolerant	4 mA		I2C3 serial data pin or GIO pin
I2C3SCL	28				I2C3 serial clock pin or GIO pin
INTER-INTEGRATED CIRCUIT 4 (I2C4)					
I2C4SDA	41	5-V tolerant	4 mA		I2C4 serial data pin or GIO pin
I2C4SCL	40				I2C4 serial clock pin or GIO pin
INTER-INTEGRATED CIRCUIT 5 (I2C5)					
I2C5SDA	38	5-V tolerant	4 mA		I2C5 serial data pin or GIO pin
I2C5SCL	37				I2C5 serial clock pin or GIO pin
ZERO-PIN PHASE-LOCKED LOOP (ZPLL)					
OSCIN	33	1.8 V			Crystal connection pin or external clock input
OSCOUT	32		2 mA		External crystal connection pin
PLLDIS	97	3.3 V		IPD (20 μ A)	Enable/disable the ZPLL. The ZPLL can be bypassed and the oscillator becomes the system clock. If not in bypass mode, TI recommends that this pin be connected to ground or pulled down to ground by an external resistor.
SERIAL COMMUNICATIONS INTERFACE 1 (SCI1)					
SCI1CLK	48	3.3 V	2 mA -z	IPD (20 μ A)	SCI1 clock. SCI1CLK can be programmed as a GIO pin.
SCI1RX	46	5-V tolerant	4 mA		SCI1 data receive. SCI1RX can be programmed as a GIO pin.
SCI1TX	45	3.3 V	2 mA -z	IPU (20 μ A)	SCI1 data transmit. SCI1TX can be programmed as a GIO pin.
SERIAL COMMUNICATIONS INTERFACE 2 (SCI2)					
SCI2CLK	51	3.3 V	2 mA -z	IPD (20 μ A)	SCI2 clock. SCI2CLK can be programmed as a GIO pin.
SCI2RX	50	5-V tolerant	4 mA		SCI2 data receive. SCI2RX can be programmed as a GIO pin.
SCI2TX	49	3.3 V	2 mA -z	IPU (20 μ A)	SCI2 data transmit. SCI2TX can be programmed as a GIO pin.
SERIAL COMMUNICATIONS INTERFACE 3 (SCI3)					
SCI3CLK	24	3.3 V	2 mA -z	IPD (20 μ A)	SCI3 clock. SCI3CLK can be programmed as a GIO pin.
SCI3RX	22	5-V tolerant	4 mA		SCI3 data receive. SCI3RX can be programmed as a GIO pin.
SCI3TX	21	3.3 V	2 mA -z	IPU (20 μ A)	SCI3 data transmit. SCI3TX can be programmed as a GIO pin.
SYSTEM MODULE (SYS)					
CLKOUT	81	3.3 V	8 mA		Bidirectional pin. CLKOUT can be programmed as a GIO pin or the output of SYSClk, ICLK, or MCLK.
PORRST	118	3.3 V		IPD (20 μ A)	Input master chip power-up reset. External V _{CC} monitor circuitry must assert a power-on reset.
RST	121	3.3 V	4 mA	IPU (20 μ A)	<p>Bidirectional reset. The internal circuitry can assert a reset, and an external system reset can assert a device reset.</p> <p>On this pin, the output buffer is implemented as an open drain (drives low only).</p> <p>To ensure an external reset is not arbitrarily generated, TI recommends that an external pullup resistor be connected to this pin.</p>

Table 2. Terminal Functions (continued)

TERMINAL		TYPE ⁽¹⁾⁽²⁾	CURRENT OUTPUT	INTERNAL PULLUP/PULLDOWN ⁽³⁾	DESCRIPTION
NAME	NO.				
WATCHDOG/REAL-TIME INTERRUPT (WD/RTI)					
AWD	36	3.3 V	8 mA		Analog watchdog reset. The AWD pin provides a system reset if the WD KEY is not written in time by the system, providing an external RC network circuit is connected. If the user is not using AWD, TI recommends that this pin be connected to ground or pulled down to ground by an external resistor. For more details on the external RC network circuit, see the <i>TMS470R1x System Module Reference Guide</i> (literature number SPNU189).
TEST/DEBUG (T/D)					
TCK	76	3.3 V		IPD (20 μ A)	Test clock. TCK controls the test hardware (JTAG).
TDI	74		8 mA	IPU (20 μ A)	Test data in. TDI inputs serial data to the test instruction register, test data register, and programmable test address (JTAG).
TDO	75		8 mA	IPD (20 μ A)	Test data out. TDO outputs serial data from the test instruction register, test data register, identification register, and programmable test address (JTAG).
TEST	124	3.3 V		IPD (20 μ A)	Test enable. Reserved for internal use only. TI recommends that this pin be connected to ground or pulled down to ground by an external resistor.
TMS	17		8 mA	IPU (20 μ A)	Serial input for controlling the state of the CPU test access port (TAP) controller (JTAG).
TMS2	16		8 mA	IPU (20 μ A)	Serial input for controlling the second TAP. TI recommends that this pin be connected to V_{CCIO} or pulled up to V_{CCIO} by an external resistor.
TRST	144			IPD (20 μ A)	Test hardware reset to TAP1 and TAP2. IEEE Standard 1149-1 (JTAG) Boundary-Scan Logic. TI recommends that this pin be pulled down to ground by an external resistor.
FLASH					
FLTP2	132	NC	NC		Flash test pad 2. For proper operation, this pin must not be connected [no connect (NC)].
V_{CCP}	131	3.3-V PWR			Flash external pump voltage (3.3 V)
SUPPLY VOLTAGE CORE (1.8 V)					
V_{CC}	13	1.8-V PWR			Core logic supply voltage
	31				
	53				
	92				
	123				
	130				
SUPPLY VOLTAGE DIGITAL I/O (3.3 V)					
V_{CCIO}	25	3.3-V PWR			Digital I/O supply voltage
	69				
	86				
	137				

Table 2. Terminal Functions (continued)

TERMINAL		TYPE ⁽¹⁾⁽²⁾	CURRENT OUTPUT	INTERNAL PULLUP/PULLDOWN ⁽³⁾	DESCRIPTION
NAME	NO.				
SUPPLY GROUND CORE					
V _{SS}	14	GND			Core supply ground reference
	34				
	52				
	91				
	122				
	129				
SUPPLY GROUND DIGITAL I/O					
V _{SSIO}	26	GND			Digital I/O supply ground reference
	68				
	85				
	138				

B1M Device-Specific Information

Memory

Figure 1 shows the memory map of the B1M device.

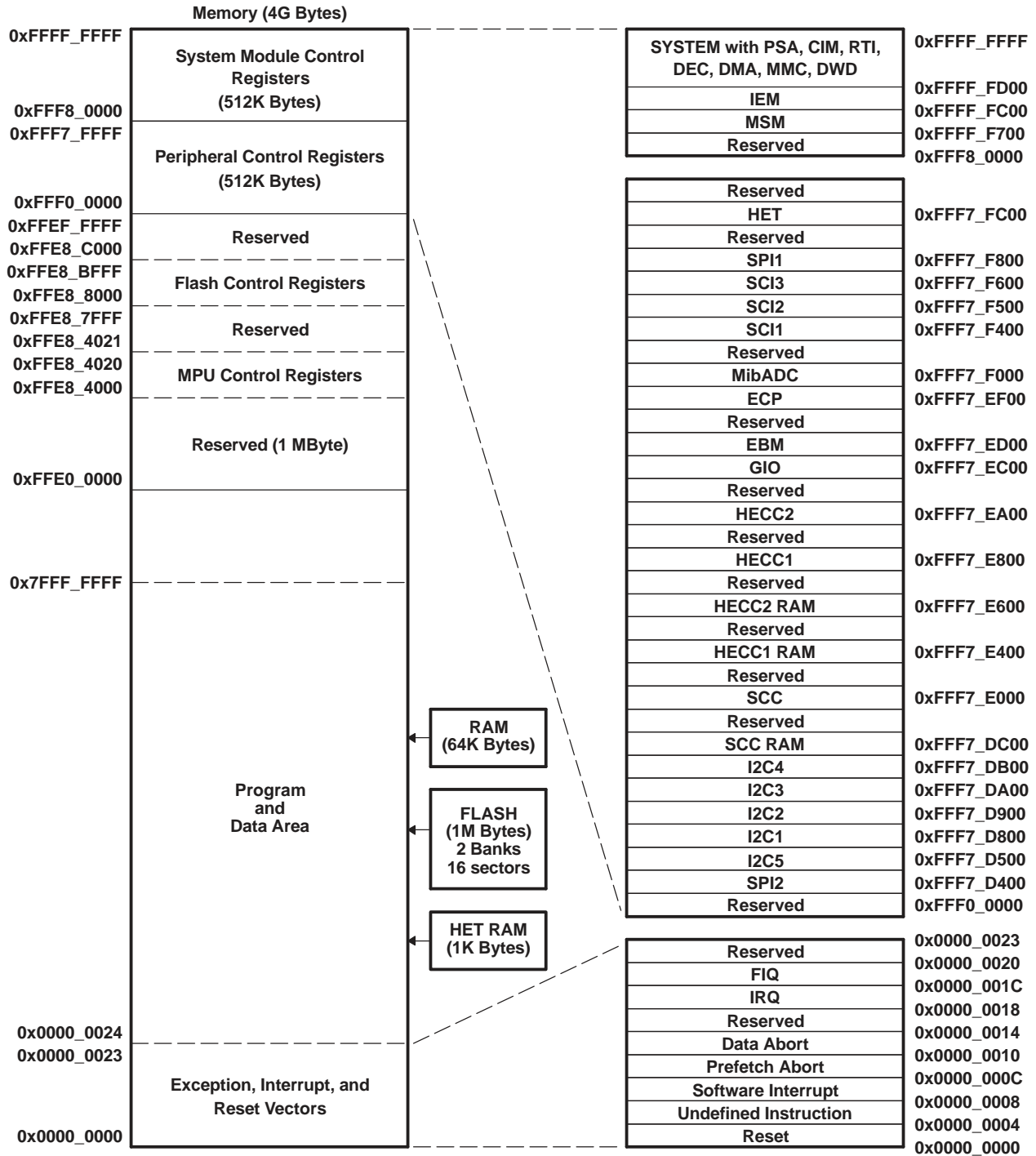

- A. Memory addresses are configurable by the system (SYS) module within the range of 0x0000_0000 to 0xFFE0_0000.
- B. The CPU registers are not part of the memory map.

Figure 1. TMS470R1B1M Memory Map

memory selects

Memory selects allow the user to address memory arrays (i.e., flash, RAM, and HET RAM) at user-defined addresses. Each memory select has its own set (low and high) of memory base address registers (MFBAHRx and MFBALRx) that, together, define the array's starting (base) address, block size, and protection.

The base address of each memory select is configurable to any memory address boundary that is a multiple of the decoded block size. For more information on how to control and configure these memory select registers, see the bus structure and memory sections of the *TMS470R1x System Module Reference Guide* (literature number SPNU189).

For the memory selection assignments and the memory selected, see [Table 3](#).

Table 3. TMS470R1B1M Memory Selection Assignment

MEMORY SELECT	MEMORY SELECTED (ALL INTERNAL)	MEMORY SIZE ⁽¹⁾	MPU	MSM	MEMORY BASE ADDRESS REGISTER	STATIC MEM CTL REGISTER
0 (fine)	FLASH/ROM	1 M	NO	YES	MFBAHR0 and MFBALR0	
1 (fine)	FLASH/ROM		NO	YES	MFBAHR1 and MFBALR1	
2 (fine)	RAM	64 K ⁽²⁾	YES	YES	MFBAHR2 and MFBALR2	
3 (fine)	RAM		YES	YES	MFBAHR3 and MFBALR3	
4 (fine)	HET RAM	1 K	NO	NO	MFBAHR4 and MFBALR4	SMCR1
5 (coarse)	$\overline{CS}[5]/\text{GIOC}[3]$	128 MB (x8) 512 K (x16)	NO	NO	MCBAHR2 and MCBALR2	SMCR5
6 (coarse)	$\overline{CS}[6]/\text{GIOC}[4]$	128 MB (x8) 512 K (x16)	NO	NO	MCBAHR3 and MCBALR3	SMCR6

(1) x8 refers to size of memory in 8-bits; x16 refers to size of memory in 16-bits.

(2) The starting addresses for both RAM memory-select signals cannot be offset from each other by a multiple of the user-defined block size in the memory-base address register.

JTAG security module

The B1M device includes a JTAG security module to provide maximum security to the memory contents. The visible unlock code can be in the OTP sector or in the first bank of the user-programmable memory. For the B1M, the visible unlock code is in the OTP sector at address 0x0000_01F8.

memory security module

The B1M device also includes a memory security module (MSM) to provide additional security and flexibility to the memory contents' protection. The password for unlocking the MSM is located in the four words just before the flash protection keys.

RAM

The B1M device contains 64K-bytes of internal static RAM configurable by the SYS module to be addressed within the range of 0x0000_0000 to 0xFFE0_0000. This B1M RAM is implemented in one 64K-byte array selected by two memory-select signals. This B1M configuration imposes an additional constraint on the memory map for RAM; the starting addresses for both RAM memory selects cannot be offset from each other by the multiples of the size of the physical RAM (i.e., 64K bytes for the B1M device). The B1M RAM is addressed through memory selects 2 and 3.

The RAM can be protected by the memory protection unit (MPU) portion of the SYS module, allowing the user finer blocks of memory protection than is allowed by the memory selects. The MPU is ideal for protecting an operating system while allowing access to the current task. For more detailed information on the MPU portion of the SYS module and memory protection, see the memory section of the *TMS470R1x System Module Reference Guide* (literature number SPNU189).

F05 Flash

The F05 flash memory is a nonvolatile electrically erasable and programmable memory implemented with a 32-bit-wide data bus interface. The F05 flash has an external state machine for programming and erase functions. See the *Flash read* and *Flash program and erase* sections.

flash protection keys

The B1M device provides flash protection keys. These four 32-bit protection keys prevent program/erase/compaction operations from occurring until after the four protection keys have been matched by the CPU loading the correct user keys into the FMPKEY control register. The protection keys on the B1M are located in the last 4 words of the first 64K sector.

flash read

The B1M flash memory is configurable by the SYS module to be addressed within the range of 0x0000_0000 to 0xFFE0_0000. The flash is addressed through memory selects 0 and 1.

NOTE:

The flash external pump voltage (V_{CCP}) is required for all operations (program, erase, and read).

flash pipeline mode

When in pipeline mode, the flash operates with a system clock frequency of up to 60 MHz (versus a system clock frequency of 30 MHz in normal mode). Flash in pipeline mode is capable of accessing 64-bit words and provides two 32-bit pipelined words to the CPU. Also, in pipeline mode the flash can be read with no wait states when memory addresses are contiguous (after the initial 1- or 2-wait-state reads).

NOTE:

After a system reset, pipeline mode is disabled (ENPIPE bit [FMREGOPT.0] is a 0). In other words, the B1M device powers up and comes out of reset in non-pipeline mode. Furthermore, setting the flash configuration mode bit (GBLCTRL.4) will override pipeline mode.

flash program and erase

The B1M device flash contains two 512K-byte memory arrays (or banks), for a total of 1M-byte of flash, and consists of sixteen sectors. These sixteen sectors are sized as follows:

SECTOR NO.	SEGMENT	LOW ADDRESS	HIGH ADDRESS	MEMORY ARRAYS (OR BANKS)
OTP	2K Bytes	0x0000_0000	0x0000_007FF	BANK0 (512K Bytes)
0	64K Bytes	0x0000_0000	0x0000_FFFF	
1	64K Bytes	0x0001_0000	0x0001_FFFF	
2	64K Bytes	0x0002_0000	0x0002_FFFF	
3	64K Bytes	0x0003_0000	0x0003_FFFF	
4	64K Bytes	0x0004_0000	0x0004_FFFF	
5	64K Bytes	0x0005_0000	0x0005_FFFF	
6	64K Bytes	0x0006_0000	0x0006_FFFF	
7	64K Bytes	0x0007_0000	0x0007_FFFF	BANK1 (512K Bytes)
0	64K Bytes	0x0008_0000	0x0008_FFFF	
1	64K Bytes	0x0009_0000	0x0009_FFFF	
2	64K Bytes	0x000A_0000	0x000A_FFFF	
3	64K Bytes	0x000B_0000	0x000B_FFFF	
4	64K Bytes	0x000C_0000	0x000C_FFFF	
5	64K Bytes	0x000D_0000	0x000D_FFFF	
6	64K Bytes	0x000E_0000	0x000E_FFFF	
7	64K Bytes	0x000F_0000	0x000F_FFFF	

The minimum size for an erase operation is one sector. The maximum size for a program operation is one 16-bit word.

NOTE:

The flash external pump voltage (V_{CCP}) is required for all operations (program, erase, and read).

Execution can occur from one bank while programming/erasing any or all sectors of another bank. However, execution cannot occur from any sector within a bank that is being programmed or erased.

NOTE:

When the OTP sector is enabled, the rest of flash memory is disabled. The OTP memory can only be read or programmed from code executed out of RAM.

HET RAM

The B1M device contains HET RAM. The HET RAM has a 64-instruction capability. The HET RAM is configurable by the SYS module to be addressed within the range of 0x0000_0000 to 0xFFE0_0000. The HET RAM is addressed through memory select 4.

peripheral selects and base addresses

The B1M device uses 10 of the 16 peripheral selects to decode the base addresses of the peripherals. These peripheral selects are fixed and transparent to the user since they are part of the decoding scheme used by the SYS module.

Control registers for the peripherals, SYS module, and flash begin at the base addresses shown in [Table 4](#).

Table 4. B1M Peripherals, System Module, and Flash Base Addresses

CONNECTING MODULE	ADDRESS RANGE		PERIPHERAL SELECTS
	BASE ADDRESS	ENDING ADDRESS	
SYSTEM	0 x FFFF_FFCC	0 x FFFF_FFFF	N/A
RESERVED	0 x FFFF_FF70	0 x FFFF_FF7F	N/A
DWD	0xFFFF_FF60	0 x FFFF_FF6F	N/A
PSA	0 x FFFF_FF40	0 x FFFF_FF5F	N/A
CIM	0 x FFFF_FF20	0 x FFFF_FF3F	N/A
RTI	0 x FFFF_FF00	0 x FFFF_FF1F	N/A
DMA	0 x FFFF_FE80	0 x FFFF_FEFF	N/A
DEC	0 x FFFF_FE00	0 x FFFF_FE7F	N/A
RESERVED	0xFFFF_FD80	0xFFFF_FDFF	N/A
MMC	0 x FFFF_FD00	0 x FFFF_FD7F	N/A
IEM	0 x FFFF_FC00	0 x FFFF_FCFF	N/A
RESERVED	0 x FFFF_Fb00	0 x FFFF_FBFF	N/A
RESERVED	0 x FFFF_Fa00	0 x FFFF_FAFF	N/A
DMA CMD BUFFER	0 x FFFF_F800	0 x FFFF_F9FF	N/A
MSM	0xFFFF_F700	0xFFFF_F7FF	N/A
RESERVED	0xFFF8_0000	0xFFFF_F6FF	N/A
RESERVED	0 x FFF7_FD00	0xFFF7_FFFF	PS[0]
HET	0xFFF7_FC00	0xFFF7_FCFE	
RESERVED	0xFFF7_F900	0xFFF7_FBFF	PS[1]
SPI1	0xFFF7_F800	0xFFF7_F8FF	
RESERVED	0xFFF7_F700	0xFFF7_F7FF	PS[2]
SCI3	0xFFF7_F600	0xFFF7_F6FF	
SCI2	0xFFF7_F500	0xFFF7_F5FF	
SCI1	0xFFF7_F400	0xFFF7_F4FF	
RESERVED	0xFFF7_F100	0xFFF7_F3FF	PS[3]
MibADC	0xFFF7_F000	0xFFF7_F0FF	
ECP	0xFFF7_EF00	0xFFF7_EFFF	PS[4]
RESERVED	0xFFF7_EE00	0xFFF7_EEFF	
EBM	0xFFF7_ED00	0xFFF7_EDFF	
GIO	0xFFF7_EC00	0xFFF7_ECFE	
HECC2	0xFFF7_EB00	0xFFF7_EBFF	PS[5]
	0xFFF7_EA00	0xFFF7_EAFF	
HECC1	0xFFF7_E900	0xFFF7_E9FF	
	0xFFF7_E800	0xFFF7_E8FF	
HECC2 RAM	0xFFF7_E700	0xFFF7_E7FF	PS[6]
	0xFFF7_E600	0xFFF7_E6FF	
HECC1 RAM	0xFFF7_E500	0xFFF7_E5FF	
	0xFFF7_E400	0xFFF7_E4FF	
RESERVED	0xFFF7_E100	0xFFF7_E3FF	PS[7]
SCC	0xFFF7_E000	0xFFF7_E0FF	

Table 4. B1M Peripherals, System Module, and Flash Base Addresses (continued)

CONNECTING MODULE	ADDRESS RANGE		PERIPHERAL SELECTS
	BASE ADDRESS	ENDING ADDRESS	
RESERVED	0xFFF7_DD00	0xFFF7_DFFF	PS[8]
SCC RAM	0xFFF7_DC00	0xFFF7_DCFE	
I2C4	0xFFF7_DB00	0xFFF7_DBFF	PS[9]
I2C3	0xFFF7_DA00	0xFFF7_DAFF	
I2C2	0xFFF7_D900	0xFFF7_D9FF	
I2C1	0xFFF7_D800	0xFFF7_D8FF	
RESERVED	0xFFF7_D600	0xFFF7_D7FF	PS[10]
I2C5	0xFFF7_D500	0xFFF7_D5FF	
SPI2	0xFFF7_D400	0xFFF7_D4FF	
RESERVED	0xFFF7_CC00	0xFFF7_D3FF	PS[11] – PS[12]
RESERVED	0xFFF7_C800	0xFFF7_CBFF	PS[13]
RESERVED	0xFFF7_C000	0xFFF7_C7FF	PS[14] – PS[15]
RESERVED	0xFFF0_0000	0xFFF7_BFFF	N/A
FLASH CONTROL REGISTERS	0xFFE8_8000	0xFFE8_BFFF	N/A
RESERVED	0xFFF8_4024	0xFFF8_7FFF	N/A
MPU CONTROL REGISTERS	0xFFE8_4000	0xFFE8_4023	N/A
RESERVED	0xFFF8_0000	0xFFF8_3FFF	N/A

direct-memory access (DMA)

The direct-memory access (DMA) controller transfers data to and from any specified location in the B1M memory map (except for restricted memory locations like the system control registers area). The DMA manages up to 16 channels, and supports data transfer for both on-chip and off-chip memories and peripherals. The DMA controller is connected to both the CPU and peripheral buses, enabling these data transfers to occur in parallel with CPU activity and thus maximizing overall system performance.

Although the DMA controller has two possible configurations, for the B1M device, the DMA controller configuration is 32 control packets and 16 channels.

For the B1M DMA request hardwired configuration, see [Table 5](#).

Table 5. DMA Request Lines Connections⁽¹⁾

MODULES	DMA REQUEST INTERRUPT SOURCES		DMA CHANNEL
EBM	Expansion Bus DMA request	EBDMAREQ[0]	DMAREQ[0]
SPI1/I2C4	SPI1 end-receive/I2C4 read	SPI1DMA0/I2C4DMA0	DMAREQ[1]
SPI1/I2C4	SPI1 end-transmit/I2C4 write	SPI1DMA1/I2C4DMA1	DMAREQ[2]
MibADC/I2C1	ADC EV/I2C1 read	MibADCDMA0/I2C1DMA0	DMAREQ[3]
MibADC/SCI1/I2C5	ADC G1/SCI1 end-receive/I2C5 read	MibADCDMA1/SCI1DMA0/I2C5DMA0	DMAREQ[4]
MibADC/SCI1/I2C5	ADC G2/SCI1 end-transmit/I2C5 write	MibADCDMA2/SCI1DMA1/I2C5DMA1	DMAREQ[5]
I2C1	I2C1 write	I2C1DMA1	DMAREQ[6]
SCI3/SPI2	SCI3 end-receive/SPI2 end-receive	SCI3DMA0/SPI2DMA0	DMAREQ[7]
SCI3/SPI2	SCI3 end-transmit/SPI2 end-transmit	SCI3DMA01/SPI2DMA1	DMAREQ[8]
I2C2	I2C2 read end-receive	I2C2DMA0	DMAREQ[9]
I2C2	I2C2 write end-transmit	I2C2DMA1	DMAREQ[10]
I2C3	I2C3 read	I2C3DMA0	DMAREQ[11]
I2C3	I2C3 write	I2C3DMA1	DMAREQ[12]
Reserved			DMAREQ[13]
SCI2	SCI2 end-receive	SCI2DMA0	DMAREQ[14]
SCI2	SCI2 end-transmit	SCI2DMA1	DMAREQ[15]

(1) For DMA channels with more than one assigned request source, *only one* of the sources listed can be the DMA request generator in a given application. The device has software control to ensure that there are no conflicts between requesting modules.

Each channel has two control packets attached to it, allowing the DMA to continuously load RAM and generate periodic interrupts so that the data can be read by the CPU. The control packets allow for the interrupt enable, and the channels determine the priority level of the interrupt.

DMA transfers occur in one of two modes:

- Non-request mode (used when transferring from memory to memory)
- Request mode (used when transferring from memory to peripheral)

For more detailed functional information on the DMA controller, see the *TMS470R1x Direct Memory Access (DMA) Controller Reference Guide* (literature number SPNU194).

interrupt priority (IEM to CIM)

Interrupt requests originating from the B1M peripheral modules (i.e., SPI1 or SPI2; SCI1 or SCI2; RTI; etc.) are assigned to channels within the 48-channel interrupt expansion module (IEM) where, via programmable register mapping, these channels are then mapped to the 32-channel central interrupt manager (CIM) portion of the SYS module.

Programming multiple interrupt sources in the IEM to the same CIM channel effectively shares the CIM channel between sources.

The CIM request channels are maskable so that individual channels can be selectively disabled. All interrupt requests can be programmed in the CIM to be of either type:

- Fast interrupt request (FIQ)
- Normal interrupt request (IRQ)

The CIM prioritizes interrupts. The precedences of request channels decrease with ascending channel order in the CIM (0 [highest] and 31 [lowest] priority). For IEM-to-CIM default mapping, channel priorities, and their associated modules, see [Table 6](#).

Table 6. Interrupt Priority (IEM and CIM)

MODULES	INTERRUPT SOURCES	DEFAULT CIM INTERRUPT LEVEL/CHANNEL	IEM CHANNEL
SPI1	SPI1 end-transfer/overrun	0	0
RTI	COMP2 interrupt	1	1
RTI	COMP1 interrupt	2	2
RTI	TAP interrupt	3	3
SPI2	SPI2 end-transfer/overrun	4	4
GIO	GIO interrupt A	5	5
Reserved		6	6
HET	HET interrupt 1	7	7
I2C1	I2C1 interrupt	8	8
SCI1/SCI2	SCI1 or SCI2 error interrupt	9	9
SCI1	SCI1 receive interrupt	10	10
Reserved		11	11
I2C2	I2C2 interrupt	12	12
HECC1	HECC1 interrupt A	13	13
SCC	SCC interrupt A	14	14
Reserved		15	15
MibADC	MibADC end event conversion	16	16
SCI2	SCI2 receive interrupt	17	17
DMA	DMA interrupt 0	18	18
I2C3	I2C3 interrupt	19	19
SCI1	SCI1 transmit interrupt	20	20
System	SW interrupt (SSI)	21	21
Reserved		22	22
HET	HET interrupt 2	23	23
HECC1	HECC1 interrupt B	24	24
SCC	SCC interrupt B	25	25
SCI2	SCI2 transmit interrupt	26	26
MibADC	MibADC end Group 1 conversion	27	27
DMA	DMA Interrupt 1	28	28
GIO	GIO interrupt B	29	29
MibADC	MibADC end Group 2 conversion	30	30
SCI3	SCI3 error interrupt	31	31

Table 6. Interrupt Priority (IEM and CIM) (continued)

MODULES	INTERRUPT SOURCES	DEFAULT CIM INTERRUPT LEVEL/CHANNEL	IEM CHANNEL
Reserved		31	32–37
HECC2	HECC2 interrupt A	31	38
HECC2	HECC2 interrupt B	31	39
SCI3	SCI3 receive interrupt	31	40
SCI3	SCI3 transmit interrupt	31	41
I2C4	I2C4 interrupt	31	42
I2C5	I2C5 interrupt	31	43
Reserved		31	44–47

For more detailed functional information on the IEM, see the *TMS470R1x Interrupt Expansion Module (IEM) Reference Guide* (literature number SPNU211). For more detailed functional information on the CIM, see the *TMS470R1x System Module Reference Guide* (literature number SPNU189).

expansion bus module (EBM)

The expansion bus module (EBM) is a standalone module used to bond out both general-purpose input/output pins and expansion bus interface pins. This module supports the multiplexing of the GIO and the expansion bus interface functions. The module also supports 8- and 16- bit expansion bus memory interface mappings as well as mapping of the following expansion bus signals:

- 27-bit address bus (EBADDR[26:0] for x8, 19-bit address bus (EBADDR[18:0] for x16
- 8- or 16-bit data bus (EBDATA[7:0] or EBDATA[15:0])
- 2 write strobes (EBWR[1:0])
- 2 memory chip selects (EBCS[6:5])
- 1 output enable (EBOE)
- 1 external hold signal for interfacing to slow memories (EBHOLD)
- 1 DMA request line (EBDMAREQ[0])

Table 7 shows the multiplexing of I/O signals with the expansion bus interface signals. The mapping of these pins varies depending on the memory mode.

Table 7. Expansion Bus Mux Mapping⁽¹⁾

GIO	EXPANSION BUS MODULE PINS	
	x8 ⁽²⁾	x16 ⁽²⁾
GIOB[0]	EBDMAREQ[0]	EBDMAREQ[0]
GIOC[0]	EBOE	EBOE
GIOC[2:1]	EBWR[1:0]	EBWR[1:0]
GIOC[4:3]	EBCS[6:5]	EBCS[6:5]
GIOD[5:0]	EBADDR[5:0]	EBADDR[5:0]
GIOE[7:0]	EBDATA[7:0]	EBDATA[7:0]
GIOF[7:0]	EBADDR[13:6]	EBDATA[15:8]
GIOG[7:0]	EBADDR[21:14]	EBADDR[13:6]
GIOH[5]	EBHOLD	EBHOLD
I2C5SDA	EBADDR[26]	EBADDR[18]
I2C5SCL	EBADDR[25]	EBADDR[17]
I2C4SCL	EBADDR[24]	EBADDR[16]
I2C4SDA	EBADDR[23]	EBADDR[15]
GIOH[0]	EBADDR[22]	EBADDR[14]

(1) For more detailed information, see the *TMS470R1x Expansion Bus Module (EBM) Reference Guide* (literature number SPNU222) and the *TMS470R1x General Purpose Input/Output Reference Guide* (literature number SPNU192).

(2) X8 refers to size of memory in 8-bits; X16 refers to size of memory in 16-bits.

Table 8 lists the names of the expansion bus interface signals and their functions.

Table 8. Expansion Bus Pins

PIN	DESCRIPTION
EBDMAREQ	Expansion bus DMA request
EBOE	Expansion bus pin enable
EBWR	Expansion bus write strobe EBWR[1] controls EBDATA[15:8] and EBWR[0] controls EBDATA[7:0]
EBCS	Expansion bus chip select
EBADDR	Expansion bus address pins
EBDATA	Expansion bus data pins
EBHOLD	Expansion bus hold: An external device may assert this signal to add wait states to an expansion bus transaction.

MibADC

The multi-buffered analog-to-digital converter (MibADC) accepts an analog signal and converts the signal to a 10-bit digital value.

The B1M MibADC module can function in two modes: compatibility mode, where its programmer's model is compatible with the TMS470R1x ADC module and its digital results are stored in digital result registers; or in buffered mode, where the digital result registers are replaced with three FIFO buffers, one for each conversion group [event, group1 (G1), and group2 (G2)]. In buffered mode, the MibADC buffers can be serviced by interrupts or by the DMA.

MibADC event trigger enhancements

The MibADC includes two major enhancements over the event-triggering capability of the TMS470R1x ADC.

- Both group 1 and the event group can be configured for event-triggered operation, providing up to two event-triggered groups.
- The trigger source and polarity can be selected individually for both group1 and the event group from the options identified in [Table 9](#).

Table 9. MibADC Event Hookup Configuration

EVENT #	SOURCE SELECT BITS FOR G1 OR EVENT (G1SRC[1:0] OR EVSRC[1:0])	SIGNAL PIN NAME
EVENT1	00	ADEVT
EVENT2	01	HET18
EVENT3	10	Reserved
EVENT4	11	Reserved

For group1, these event-triggered selections are configured via the group 1 source select bits (G1SRC[1:0]) in the AD event source register (ADEVTSRC[5:4]). For the event group, these event-triggered selections are configured via the event group source select bits (EVSRC[1:0]) in the AD event source register (ADEVTSRC[1:0]).

For more detailed functional information on the MibADC, see the *TMS470R1x Multi-Buffered Analog-to-Digital Converter (MibADC) Reference Guide* (literature number SPNU206).

JTAG Interface

There are two main test access ports (TAPs) on the device:

- TMS470R1x CPU TAP
- Device TAP for factory test

Some of the JTAG pins are shared among these two TAPs. The hookup is illustrated in [Figure 2](#).

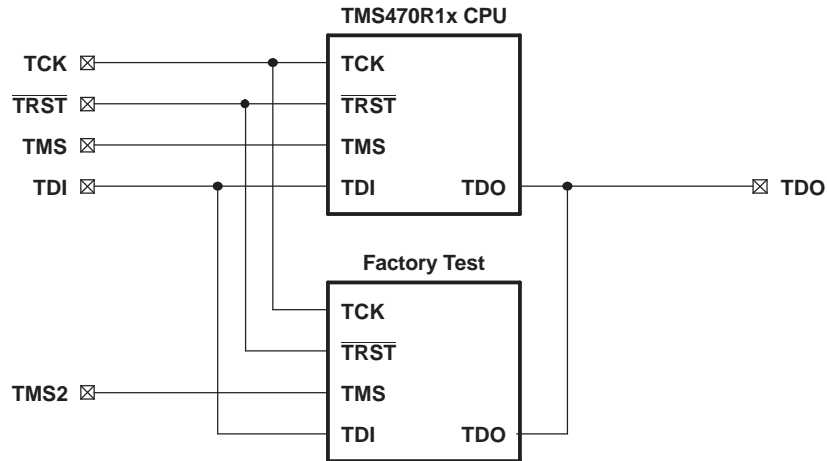

Figure 2. JTAG Interface

documentation support

Extensive documentation supports all of the TMS470 microcontroller family generation of devices. The types of documentation available include data sheets with design specifications; complete user's guides for all devices and development support tools; and hardware and software applications. Useful reference documentation includes:

- Bulletin
 - *TMS470 Microcontroller Family Product Bulletin* (literature number SPNB086)
- User's Guides
 - *TMS470R1x System Module Reference Guide* (literature number SPNU189)
 - *TMS470R1x General Purpose Input/Output (GPIO) Reference Guide* (literature number SPNU192)
 - *TMS470R1x Direct Memory Access (DMA) Controller Reference Guide* (literature number SPNU194)
 - *TMS470R1x Direct Memory Access (DMA) Controller Reference Guide* (literature number SPNU194)
 - *TMS470R1x Serial Peripheral Interface (SPI) Reference Guide* (literature number SPNU195)
 - *TMS470R1x Serial Communication Interface (SCI) Reference Guide* (literature number SPNU196)
 - *TMS470R1x Controller Area Network (CAN) Reference Guide* (literature number SPNU197)
 - *TMS470R1x High End Timer (HET) Reference Guide* (literature number SPNU199)
 - *TMS470R1x External Clock Prescale (ECP) Reference Guide* (literature number SPNU202)
 - *TMS470R1x MultiBuffered Analog to Digital (MibADC) Reference Guide* (literature number SPNU206)
 - *TMS470R1x Zero Pin Phase Locked Loop (ZPLL) Clock Module Reference Guide* (literature number SPNU212)
 - *TMS470R1x Digital Watchdog Timer Reference Guide* (literature number SPNU244)
 - *TMS470R1x Interrupt Expansion Module (IEM) Reference Guide* (literature number SPNU211)
 - *TMS470R1x Class II Serial Interface B (C2SIb) Reference Guide* (literature number SPNU214)
 - *TMS470R1x Class II Serial Interface A (C2SIa) Reference Guide* (literature number SPNU218)
 - *TMS470R1x Expansion Bus Module (EBM) Reference Guide* (literature number SPNU222)
 - *TMS470R1x Inter-Integrated Circuit (I2C) Reference Guide* (literature number SPNU223)
 - *TMS470R1x JTAG Security Module (JSM) Reference Guide* (literature number SPNU245)
 - *TMS470R1x Memory Security Module (MSM) Reference Guide* (literature number SPNU246)
 - *TMS470 Peripherals Overview Reference Guide* (literature number SPNU248)
- Errata Sheet
 - *TMS470R1B1M TMS470 Microcontrollers Silicon Errata* (literature number SPNZ139)

Device and Development-Support Tool Nomenclature

To designate the stages in the product development cycle, TI assigns prefixes to the part numbers of all DSP devices and support tools. Each DSP commercial family member has one of three prefixes: TMX, TMP, or TMS (e.g., **TMS470R1B1M**). Texas Instruments recommends two of three possible prefix designators for its support tools: TMDX and TMDS. These prefixes represent evolutionary stages of product development from engineering prototypes (TMX/TMDX) through fully qualified production devices/tools (TMS/TMDS).

Device development evolutionary flow:

TMX Experimental device that is not necessarily representative of the final device's electrical specifications

TMP Final silicon die that conforms to the device's electrical specifications but has not completed quality and reliability verification

TMS Fully qualified production device

Support tool development evolutionary flow:

TMDX Development-support product that has not yet completed Texas Instruments internal qualification testing.

TMDS Fully qualified development-support product

TMX and TMP devices and TMDX development-support tools are shipped against the following disclaimer:

"Developmental product is intended for internal evaluation purposes."

TMS devices and TMDS development-support tools have been characterized fully, and the quality and reliability of the device have been demonstrated fully. TI's standard warranty applies.

Predictions show that prototype devices (TMX or TMP) have a greater failure rate than the standard production devices. Texas Instruments recommends that these devices not be used in any production system because their expected end-use failure rate still is undefined. Only qualified production devices are to be used.

[Figure 3](#) illustrates the numbering and symbol nomenclature for the TMS470R1x family.

TMS470R1B1M

16/32-Bit RISC Flash Microcontroller

SPNS109A—SEPTEMBER 2005—REVISED AUGUST 2006

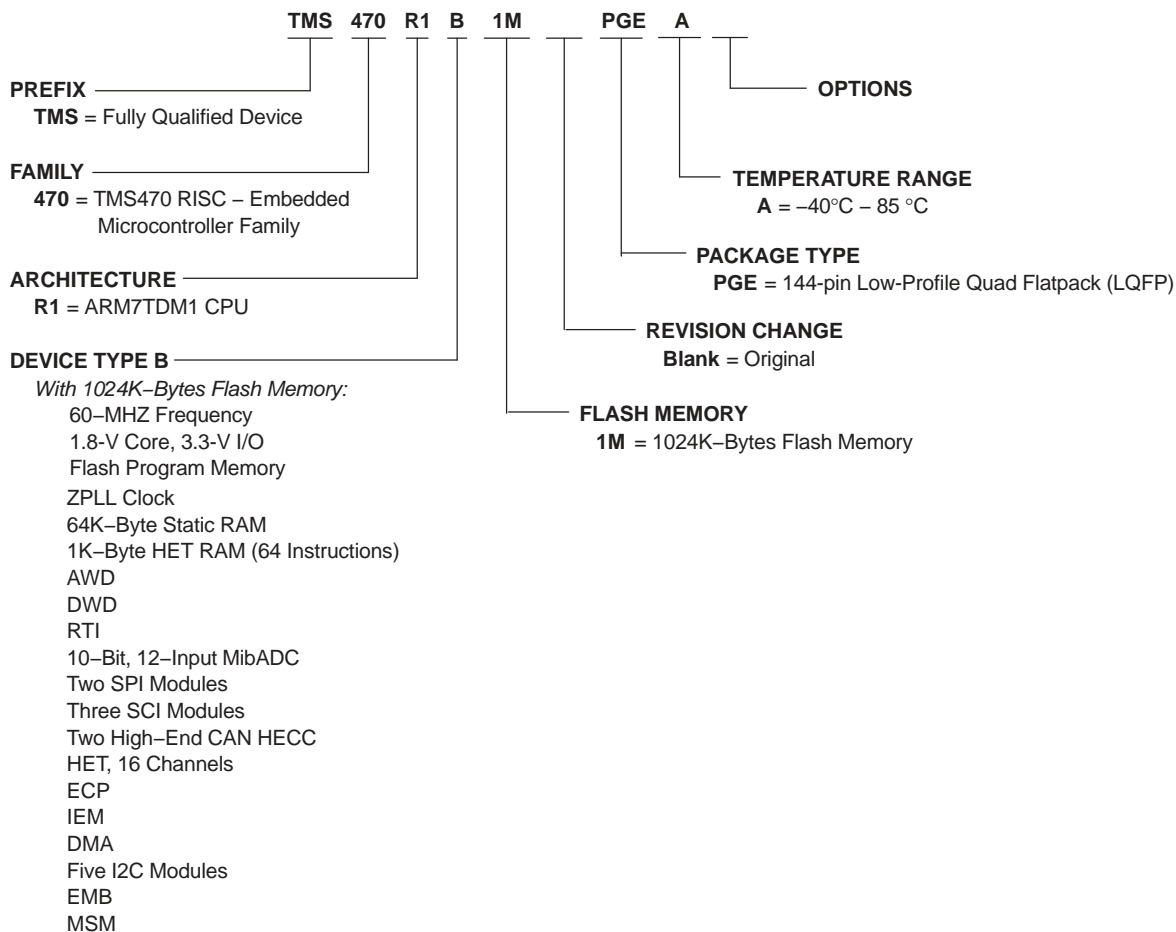
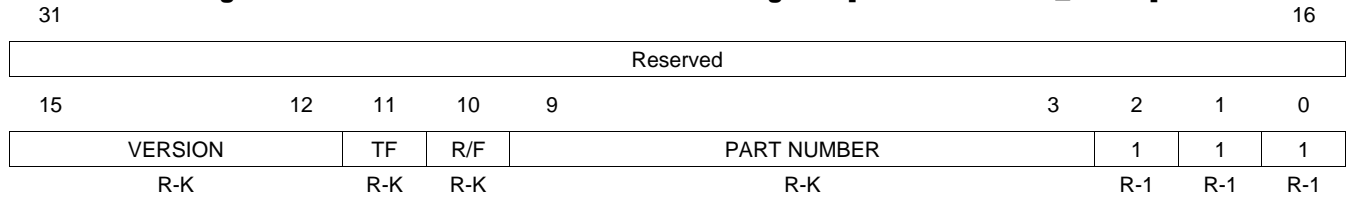

Figure 3. TMS470R1x Family Nomenclature

device identification code register

The device identification code register identifies the silicon version, the technology family (TF), a ROM or flash device, and an assigned device-specific part number (see Table 10). The B1M device identification code register value is 0xnA5F.

Figure 4. TMS470 Device ID Bit Allocation Register [offset = 0xFFFF_FFF0h]



LEGEND:

For bits 3-15: R = Read only, -K = Value constant after $\overline{\text{RESET}}$.

For bits 0-2: R = Read only, -1 = Value after $\overline{\text{RESET}}$.

Table 10. TMS470 Device ID Bit Allocation Register Field Descriptions

Bit	Field	Value	Description
31-16	Reserved		Reads are undefined and writes have no effect.
15-12	VERSION		Silicon version (revision) bits These bits identify the silicon version of the device.
11	TF	0 1	Technology family bit This bit distinguishes the technology family core power supply: 0 3.3 V for F10/C10 devices 1 1.8 V for F05/C05 devices
10	R/F	0 1	ROM/flash bit This bit distinguishes between ROM and flash devices: 0 Flash device 1 ROM device
9-3	PART NUMBER		Device-specific part number bits These bits identify the assigned device-specific part number. The assigned device-specific part number for the B1M device is 1001011.
2-0	1		Mandatory High Bits 2, 1, and 0 are tied high by default.

DEVICE ELECTRICAL SPECIFICATIONS AND TIMING PARAMETERS

Absolute Maximum Ratings

over operating free-air temperature range, A version (unless otherwise noted)⁽¹⁾

Supply voltage range:	$V_{CC}^{(2)}$	–0.3 V to 2.5 V
Supply voltage range:	V_{CCIO} , V_{CCAD} , V_{CCP} (flash pump) ⁽²⁾	–0.3 V to 4.1 V
Input voltage range:	All 5 V tolerant input pins	– 0.3 V to 6.0 V
	All other input pins	–0.3 V to 4.1 V
Input clamp current:	I_{IK} ($V_I < 0$ or $V_I > V_{CCIO}$) All pins except ADIN[0:11], \overline{PORRST} , \overline{TRST} , TEST, and TCK	±20 mA
	I_{IK} ($V_I < 0$ or $V_I > V_{CCAD}$) ADIN[0:11]	±10 mA
Operating free-air temperature range, T_A :	A version	–40°C to 85°C
Operating junction temperature range, T_J :		–40°C to 150°C
Storage temperature range, T_{stg} :		–40°C to 150°C

(1) Stresses beyond those listed under "absolute maximum ratings" may cause permanent damage to the device. These are stress ratings only, and functional operation of the device at these or any other conditions beyond those indicated under "recommended operating conditions" is not implied. Exposure to absolute-maximum-rated conditions for extended periods may affect device reliability.

(2) All voltage values are with respect to their associated grounds.

Device Recommended Operating Conditions⁽¹⁾

			MIN	NOM	MAX	UNIT
V_{CC}	Digital logic supply voltage (Core)	SYSCLK = 48 MHz (pipeline mode enabled)	1.71		2.05	V
		SYSCLK = 60 MHz (pipeline mode enabled)	1.81		2.05	
V_{CCIO}	Digital logic supply voltage (I/O)		3		3.6	V
V_{CCAD}	ADC supply voltage		3		3.6	V
V_{CCP}	Flash pump supply voltage		3		3.6	V
V_{SS}	Digital logic supply ground			0		V
V_{SSAD}	ADC supply ground ⁽¹⁾		–0.1		0.1	V
T_A	Operating free-air temperature	A version	–40		85	° C
T_J	Operating junction temperature		–40		150	° C

(1) All voltages are with respect to V_{SS} , except V_{CCAD} , which is with respect to V_{SSAD} .

ELECTRICAL CHARACTERISTICS

over recommended operating free-air temperature range⁽¹⁾

PARAMETER		TEST CONDITIONS	MIN	TYP ⁽²⁾	MAX	UNIT		
V _{hys}	Input hysteresis		0.15			V		
V _{IL}	Low-level input voltage	All inputs ⁽³⁾	-0.3		0.8	V		
V _{IH}	High-level input voltage	All inputs	2		V _{CCIO} + 0.3	V		
V _{IH}	Input threshold voltage	AWD only ⁽⁴⁾	1.35		1.8	V		
V _{OL}	Low-level output voltage ⁽⁵⁾		I _{OL} = I _{OL} MAX		0.2 V _{CCIO}	V		
			I _{OL} = 50 μA		0.2			
V _{OH}	High-level output voltage ⁽⁵⁾		I _{OH} = I _{OH} MIN		0.8 V _{CCIO}	V		
			I _{OH} = 50 μA		V _{CCIO} - 0.2			
I _{IC}	Input clamp current (I/O pins) ⁽⁶⁾		V _I < V _{SSIO} - 0.3 or V _I > V _{CCIO} + 0.3		-2	2	mA	
I _I	Input current (3.3 V input pins)	I _{IL} Pulldown	V _I = V _{SS}		-1	1	μA	
		I _{IH} Pulldown	V _I = V _{CCIO}		5	40		
		I _{IL} Pullup	V _I = V _{SS}		-40	-5		
		I _{IH} Pullup	V _I = V _{CCIO}		-1	1		
		All other pins	No pullup or pulldown		-1	1		
	Input current (5 V tolerant input pins)			V _I = V _{SS}		-1	1	μA
				V _I = V _{CCIO}		1	5	
				V _I = 5 V		5	25	
				V _I = 5.5 V		25	50	
	I _{OL}	Low-level output current	CLKOUT, AWD, TDI, TDO, TMS, TMS2	V _{OL} = V _{OL} MAX		8		mA
$\overline{\text{RST}}$			4					
All other 3.3 V I/O ⁽⁷⁾			2					
5 V tolerant			4					
I _{OH}	High-level output current	CLKOUT, TDI, TDO, TMS, TMS2	V _{OH} = V _{OH} MIN		-8		mA	
		$\overline{\text{RST}}$			-4			
		All other 3.3 V I/O ⁽⁷⁾			-2			
		5 V tolerant			-4			
I _{CC}	V _{CC} Digital supply current (operating mode)		SYSCLK = 48 MHz, ICLK = 24 MHz, V _{CC} = 2.05 V		110	mA		
	V _{CC} Digital supply current (standby mode) ⁽⁸⁾⁽⁹⁾		SYSCLK = 60 MHz, ICLK = 30 MHz, V _{CC} = 2.05 V		125	mA		
	V _{CC} Digital supply current (halt mode) ⁽⁸⁾⁽⁹⁾		OSCIN = 5 MHz, V _{CC} = 2.05 V		1.30	mA		
	V _{CC} Digital supply current (halt mode) ⁽⁸⁾⁽⁹⁾		All frequencies, V _{CC} = 2.05 V		700	μA		

- (1) Source currents (out of the device) are negative while sink currents (into the device) are positive.
- (2) The typical values indicated in this table are the expected values during operation under normal operating conditions: nominal V_{CC}, V_{CCIO}, or V_{CCAD}, room temperature.
- (3) This does not apply to the $\overline{\text{PORRST}}$ pin. For $\overline{\text{PORRST}}$ exceptions, see the $\overline{\text{RST}}$ and $\overline{\text{PORRST}}$ Timings section.
- (4) These values help to determine the external RC network circuit. For more details, see the *TMS470R1x System Module Reference Guide* (literature number SPNU189).
- (5) V_{OL} and V_{OH} are linear with respect to the amount of load current (I_{OL}/I_{OH}) applied.
- (6) Parameter does not apply to input-only or output-only pins.
- (7) Some of the 2 mA buffers on this device are zero-dominant buffers, as indicated by a -z in the Output Current column of the Terminal Functions table. If two of these buffers are shorted together and one is outputting a low level and the other is outputting a high level, the resulting value will always be low.
- (8) For flash banks/pumps in sleep mode.
- (9) For reduced power consumption in low power mode, CANSRX and CANSTX should be driven output LOW.

ELECTRICAL CHARACTERISTICS (continued)

over recommended operating free-air temperature range

PARAMETER		TEST CONDITIONS	MIN	TYP ⁽²⁾	MAX	UNIT
I _{CCIO}	V _{CCIO} Digital supply current (operating mode)	No DC load, V _{CCIO} = 3.6 V ⁽¹⁰⁾			15	mA
	V _{CCIO} Digital supply current (standby mode) ⁽⁹⁾	No DC load, V _{CCIO} = 3.6 V ⁽¹⁰⁾			10	μA
	V _{CCIO} Digital supply current (halt mode) ⁽⁹⁾	No DC load, V _{CCIO} = 3.6 V ⁽¹⁰⁾			10	μA
I _{CCAD}	V _{CCAD} supply current (operating mode)	All frequencies, V _{CCAD} = 3.6 V			15	mA
	V _{CCAD} supply current (standby mode)	All frequencies, V _{CCAD} = 3.6 V			10	μA
	V _{CCAD} supply current (halt mode)	All frequencies, V _{CCAD} = 3.6 V			10	μA
I _{CCP}	V _{CCP} pump supply current	SYSCLK = 48 MHz, V _{CCP} = 3.6 V read operation			45	mA
		SYSCLK = 60 MHz, V _{CCP} = 3.6 V read operation			55	mA
		V _{CCP} = 3.6 V program and erase			70	mA
		V _{CCP} = 3.6 V standby mode operation ⁽⁸⁾			10	μA
		V _{CCP} = 3.6 V halt mode operation ⁽⁸⁾			10	μA
C _I	Input capacitance			2	pF	
C _O	Output capacitance			3	pF	

(10) I/O pins configured as inputs or outputs with no load. All pulldown inputs ≤ 0.2 V. All pullup inputs ≥ V_{CCIO} - 0.2 V.

Parameter Measurement Information

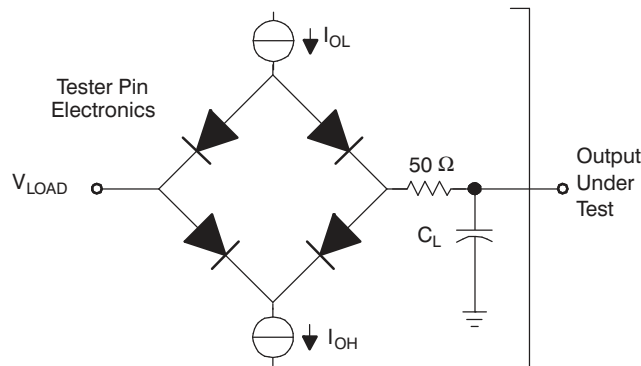

Where: I_{OL} = I_{OL} MAX for the respective pin^(A)
I_{OH} = I_{OH} MIN for the respective pin^(A)
V_{LOAD} = 1.5 V
C_L = 150-pF typical load-circuit capacitance^(B)

- A. For these values, see the "Electrical Characteristics over Recommended Operating Free-Air Temperature Range" table.
- B. All timing parameters measured using an external load capacitance of 150 pF unless otherwise noted.

Figure 5. Test Load Circuit

Timing Parameter Symbology

Timing parameter symbols have been created in accordance with JEDEC Standard 100. To shorten the symbols, some of the pin names and other related terminology have been abbreviated as follows:

CM	Compaction, CMPCT	RD	Read
CO	CLKOUT	RST	Reset, \overline{RST}
ER	Erase	RX	SCInRX
ICLK	Interface clock	S	Slave mode
M	Master mode	SCC	SCInCLK
OSC, OSCI	OSCIN	SIMO	SPInSIMO
OSCO	OSCOOUT	SOMI	SPInSOMI
P	Program, PROG	SPC	SPInCLK
R	Ready	SYS	System clock
R0	Read margin 0, RDMRGN0	TX	SCInTX
R1	Read margin 1, RDMRGN1		

Lowercase subscripts and their meanings are:

a	access time	r	rise time
c	cycle time (period)	su	setup time
d	delay time	t	transition time
f	fall time	v	valid time
h	hold time	w	pulse duration (width)

The following additional letters are used with these meanings:

H	High	X	Unknown, changing, or don't care level
L	Low	Z	High impedance
V	Valid		

External Reference Resonator/Crystal Oscillator Clock Option

The oscillator is enabled by connecting the appropriate fundamental 4–10 MHz resonator/crystal and load capacitors across the external OSCIN and OSCOUT pins as shown in Figure 6a. The oscillator is a single-stage inverter held in bias by an integrated bias resistor. This resistor is disabled during leakage test measurement and HALT mode. **TI strongly encourages each customer to submit samples of the device to the resonator/crystal vendors for validation.** The vendors are equipped to determine what load capacitors will best tune their resonator/crystal to the microcontroller device for optimum start-up and operation over temperature/voltage extremes.

An external oscillator source can be used by connecting a 1.8-V clock signal to the OSCIN pin and leaving the OSCOUT pin unconnected (open) as shown in Figure 6b.

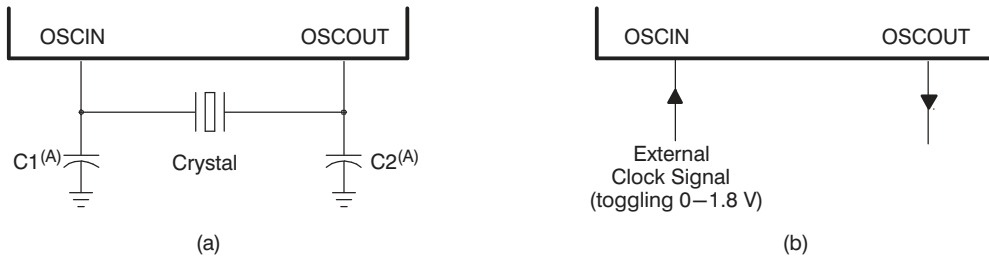

A. The values of C1 and C2 should be provided by the resonator/crystal vendor.

Figure 6. Crystal/Clock Connection

ZPLL AND CLOCK SPECIFICATIONS

Timing Requirements for ZPLL Circuits Enabled or Disabled

		MIN	TYP	MAX	UNIT
$f_{(OSC)}$	Input clock frequency	4		10	MHz
$t_{c(OISC)}$	Cycle time, OSCIN	100			ns
$t_{w(OISCIL)}$	Pulse duration, OSCIN low	15			ns
$t_{w(OISCIH)}$	Pulse duration, OSCIN high	15			ns
$f_{(OSCRST)}$	OSC FAIL frequency ⁽¹⁾		53		kHz

- (1) Causes a device reset (specifically a clock reset) by setting the RST OSC FAIL (GLBCTRL.15) and the OSC FAIL flag (GLBSTAT.1) bits equal to 1. For more detailed information on these bits and device resets, see the *TMS470R1x System Module Reference Guide* (literature number SPNU189).

Switching Characteristics over Recommended Operating Conditions for Clocks⁽¹⁾⁽²⁾⁽³⁾

PARAMETER		TEST CONDITIONS ⁽⁴⁾	MIN	MAX	UNIT
$f_{(SYS)}$	System clock frequency ⁽⁵⁾	Pipeline mode enabled		60 ⁽⁶⁾	MHz
		Pipeline mode disabled		24	MHz
$f_{(CONFIG)}$	System clock frequency - flash config mode			24	MHz
$f_{(ICLK)}$	Interface clock frequency	Pipeline mode enabled		30	MHz
		Pipeline mode disabled		24	MHz
$f_{(ECLK)}$	External clock output frequency for ECP module	Pipeline mode enabled		30	MHz
		Pipeline mode disabled		24	MHz
$t_{c(SYS)}$	Cycle time, system clock	Pipeline mode enabled	16.7		ns
		Pipeline mode disabled	41.6		ns
$t_{c(CONFIG)}$	Cycle time, system clock - flash config mode		41.6		ns
$t_{c(ICLK)}$	Cycle time, interface clock	Pipeline mode enabled	33.3		ns
		Pipeline mode disabled	41.6		ns
$t_{c(ECLK)}$	Cycle time, ECP module external clock output	Pipeline mode enabled	33.3		ns
		Pipeline mode disabled	41.6		ns

- (1) $f_{(SYS)} = M \times f_{(OSC)}/R$, where $M = \{8\}$, $R = \{1,2,3,4,5,6,7,8\}$ when $PLLDIS = 0$. R is the system-clock divider determined by the CLKDIVPRE [2:0] bits in the global control register (GLBCTRL[2:0]) and M is the PLL multiplier determined by the MULT4 bit also in the GLBCTRL register (GLBCTRL.3).
- $f_{(SYS)} = f_{(OSC)}/R$, where $R = \{1,2,3,4,5,6,7,8\}$ when $PLLDIS = 1$.
- $f_{(ICLK)} = f_{(SYS)}/X$, where $X = \{1,2,3,4,5,6,7,8,9,10,11,12,13,14,15,16\}$. X is the interface clock divider ratio determined by the PCR0[4:1] bits in the SYS module.
- (2) $f_{(ECLK)} = f_{(ICLK)}/N$, where $N = \{1 \text{ to } 256\}$. N is the ECP prescale value defined by the ECPCTRL[7:0] register bits in the ECP module.
- (3) Only ZPLL mode is available. FM mode must not be turned on.
- (4) Pipeline mode enabled or disabled is determined by the ENPIPE bit (FMREGOPT.0).
- (5) Flash Vread must be set to 5 V to achieve maximum system clock frequency.
- (6) Operating V_{CC} range for this system clock frequency is 1.81 to 2.05 V.

Switching Characteristics over Recommended Operating Conditions for External Clocks⁽¹⁾⁽²⁾⁽³⁾

(see [Figure 7](#) and [Figure 8](#))

PARAMETER		TEST CONDITIONS	MIN	MAX	UNIT
$t_{w(COL)}$	Pulse duration, CLKOUT low	SYSCLK or MCLK ⁽⁴⁾	$0.5t_{c(SYS)} - t_f$		ns
		ICLK: X is even or 1 ⁽⁵⁾	$0.5t_{c(ICLK)} - t_f$		
		ICLK: X is odd and not 1 ⁽⁵⁾	$0.5t_{c(ICLK)} + 0.5t_{c(SYS)} - t_f$		
$t_{w(COH)}$	Pulse duration, CLKOUT high	SYSCLK or MCLK ⁽⁴⁾	$0.5t_{c(SYS)} - t_f$		ns
		ICLK: X is even or 1 ⁽⁵⁾	$0.5t_{c(ICLK)} - t_f$		
		ICLK: X is odd and not 1 ⁽⁵⁾	$0.5t_{c(ICLK)} - 0.5t_{c(SYS)} - t_f$		
$t_{w(EOL)}$	Pulse duration, ECLK low	N is even and X is even or odd	$0.5t_{c(ECLK)} - t_f$		ns
		N is odd and X is even	$0.5t_{c(ECLK)} - t_f$		
		N is odd and X is odd and not 1	$0.5t_{c(ECLK)} + 0.5t_{c(SYS)} - t_f$		
$t_{w(EOH)}$	Pulse duration, ECLK high	N is even and X is even or odd	$0.5t_{c(ECLK)} - t_f$		ns
		N is odd and X is even	$0.5t_{c(ECLK)} - t_f$		
		N is odd and X is odd and not 1	$0.5t_{c(ECLK)} - 0.5t_{c(SYS)} - t_f$		

- (1) X = {1,2,3,4,5,6,7,8,9,10,11,12,13,14,15,16}. X is the interface clock divider ratio determined by the PCR0[4:1] bits in the SYS module.
- (2) N = {1 to 256}. N is the ECP prescale value defined by the ECPCTRL[7:0] register bits in the ECP module.
- (3) CLKOUT/ECLK pulse durations (low/high) are a function of the OSCIN pulse durations when PLLDIS is active.
- (4) Clock source bits are selected as either SYSCLK (CLKCNTL[6:5] = 11 binary) or MCLK (CLKCNTL[6:5] = 10 binary).
- (5) Clock source bits are selected as ICLK (CLKCNTL[6:5] = 01 binary).

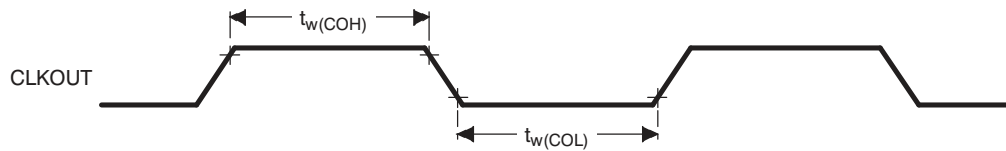

Figure 7. CLKOUT Timing Diagram

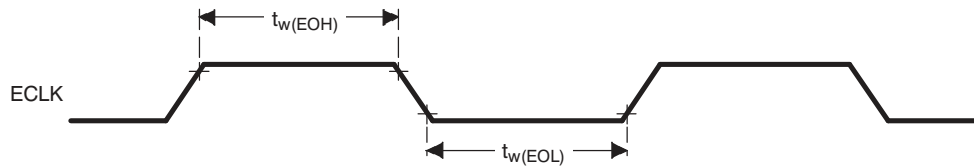

Figure 8. ECLK Timing Diagram

RST AND PORRST TIMINGS

Timing Requirements for PORRST

(see Figure 9)

		MIN	MAX	UNIT
V_{CCPORL}	V_{CC} low supply level when \overline{PORRST} must be active during power up		0.6	V
V_{CCPORH}	V_{CC} high supply level when \overline{PORRST} must remain active during power up and become active during power down	1.5		V
$V_{CCIOPORL}$	V_{CCIO} low supply level when \overline{PORRST} must be active during power up		1.1	V
$V_{CCIOPORH}$	V_{CCIO} high supply level when \overline{PORRST} must remain active during power up and become active during power down	2.75		V
V_{IL}	Low-level input voltage after $V_{CCIO} > V_{CCIOPORH}$		$0.2 V_{CCIO}$	V
$V_{IL(PORRST)}$	Low-level input voltage of \overline{PORRST} before $V_{CCIO} > V_{CCIOPORL}$		0.5	V
$t_{su(PORRST)r}$	Setup time, \overline{PORRST} active before $V_{CCIO} > V_{CCIOPORL}$ during power up	0		ms
$t_{su(VCCIO)r}$	Setup time, $V_{CCIO} > V_{CCIOPORL}$ before $V_{CC} > V_{CCPORL}$	0		ms
$t_{h(PORRST)r}$	Hold time, \overline{PORRST} active after $V_{CC} > V_{CCPORH}$	1		ms
$t_{su(PORRST)f}$	Setup time, \overline{PORRST} active before $V_{CC} \leq V_{CCPORH}$ during power down	8		μ s
$t_{h(PORRST)rio}$	Hold time, \overline{PORRST} active after $V_{CC} > V_{CCIOPORH}$	1		ms
$t_{h(PORRST)d}$	Hold time, \overline{PORRST} active after $V_{CC} < V_{CCPORL}$	0		ms
$t_{su(PORRST)fo}$	Setup time, \overline{PORRST} active before $V_{CC} \leq V_{CCIOPORH}$ during power down	0		ns
$t_{su(VCCIO)f}$	Setup time, $V_{CC} < V_{CCPORL}$ before $V_{CCIO} < V_{CCIOPORL}$	0		ns

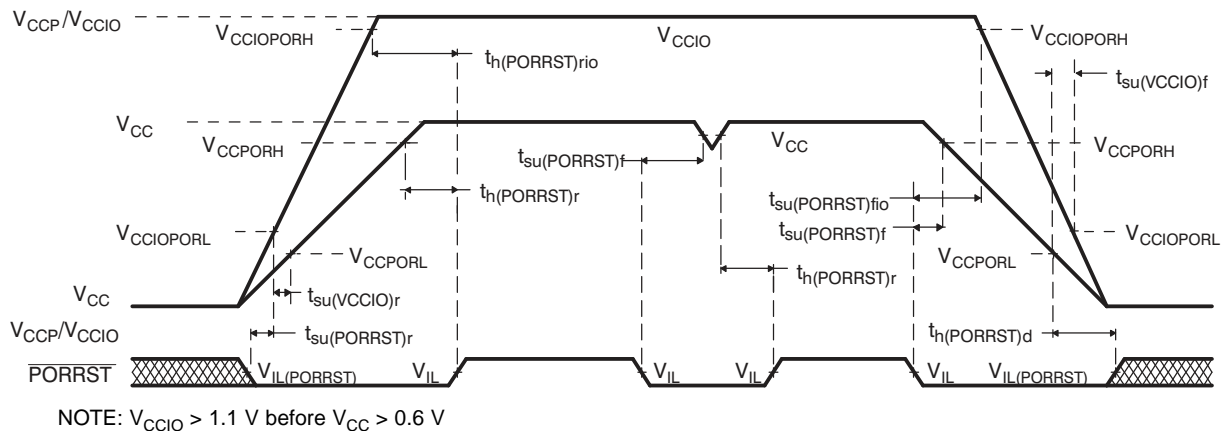

Figure 9. \overline{PORRST} Timing Diagram

Switching Characteristics over Recommended Operating Conditions for $\overline{RST}^{(1)}$

PARAMETER		MIN	MAX	UNIT
$t_{v(RST)}$	Valid time, \overline{RST} active after \overline{PORRST} inactive	$4112t_{c(OSC)}$		ns
	Valid time, \overline{RST} active (all others)	$8t_{c(SYS)}$		
t_{fsu}	Flash start up time, from \overline{RST} inactive to fetch of first instruction from flash (flash pump stabilization time)	$836t_{c(OSC)}$		ns

(1) Specified values do NOT include rise/fall times. For rise and fall timings, see the "switching characteristics for output timings versus load capacitance" table.

JTAG SCAN INTERFACE TIMING (JTAG CLOCK SPECIFICATION 10-MHz AND 50-pF LOAD ON TDO OUTPUT)

		MIN	MAX	UNIT
$t_{c(JTAG)}$	Cycle time, JTAG low and high period	50		ns
$t_{su(TDI/TMS - TCKr)}$	Setup time, TDI, TMS before TCK rise (TCKr)	15		ns
$t_{h(TCKr - TDI/TMS)}$	Hold time, TDI, TMS after TCKr	15		ns
$t_{h(TCKf - TDO)}$	Hold time, TDO after TCKf	10		ns
$t_{d(TCKf - TDO)}$	Delay time, TDO valid after TCK fall (TCKf)		45	ns

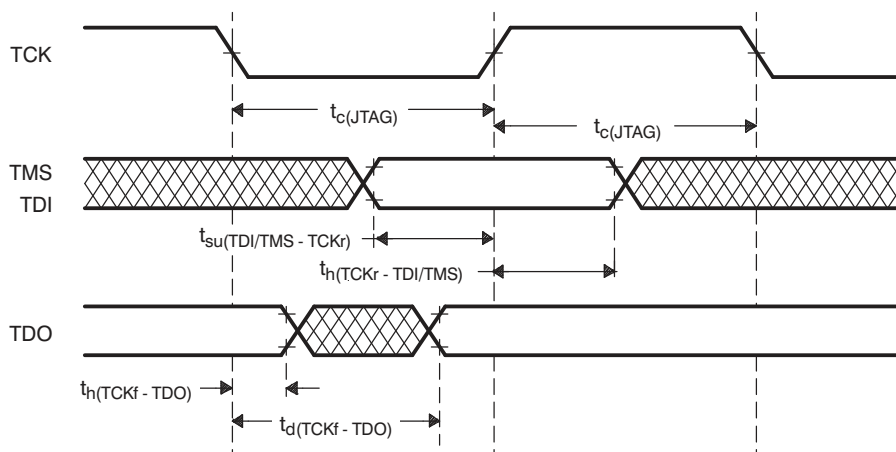

Figure 10. JTAG Scan Timings

OUTPUT TIMINGS

Switching Characteristics for Output Timings versus Load Capacitance (C_L)

(see Figure 11)

PARAMETER		MIN	MAX	UNIT	
t _r	Rise time, AWD, CLKOUT, $\overline{\text{TDI}}$, $\overline{\text{TDO}}$, TMS, TMS2	C _L = 15 pF	0.5	2.5	ns
		C _L = 50 pF	1.5	5.0	
		C _L = 100 pF	3.0	9.0	
		C _L = 150 pF	4.5	12.5	
t _f	Fall time, AWD, CLKOUT, $\overline{\text{TDI}}$, $\overline{\text{TDO}}$, TMS, TMS2	C _L = 15 pF	0.5	2.5	ns
		C _L = 50 pF	1.5	5.0	
		C _L = 100 pF	3.0	9.0	
		C _L = 150 pF	4.5	12.5	
t _r	Rise time, $\overline{\text{RST}}$	C _L = 15 pF	2.5	8	ns
		C _L = 50 pF	5	14	
		C _L = 100 pF	9	23	
		C _L = 150 pF	13	32	
t _r	Rise time, 4mA, 5 V tolerant pins	C _L = 15 pF	3	10	ns
		C _L = 50 pF	3.5	12	
		C _L = 100 pF	7	21	
		C _L = 150 pF	9	28	
t _f	Fall time, 4mA, 5 V tolerant pins	C _L = 15 pF	2	8	ns
		C _L = 50 pF	2.5	9	
		C _L = 100 pF	8	25	
		C _L = 150 pF	11	35	
t _r	Rise time, all other output pins	C _L = 15 pF	2.5	10	ns
		C _L = 50 pF	6.0	25	
		C _L = 100 pF	12	45	
		C _L = 150 pF	18	65	
t _f	Fall time, all other output pins	C _L = 15 pF	3	10	ns
		C _L = 50 pF	8.5	25	
		C _L = 100 pF	16	45	
		C _L = 150 pF	23	65	

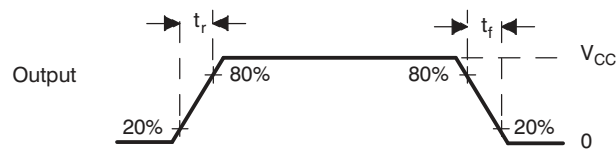

Figure 11. CMOS-Level Outputs

INPUT TIMINGS

Timing Requirements for Input Timings⁽¹⁾

(see Figure 12)

		MIN	MAX	UNIT
t_{pw}	Input minimum pulse width	$t_{c(ICKL)} + 10$		ns

(1) $t_{c(ICKL)}$ = interface clock cycle time = $1/f_{(ICKL)}$

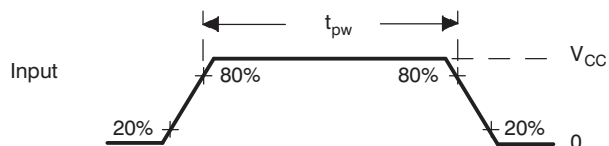

Figure 12. CMOS-Level Inputs

FLASH TIMINGS

Timing Requirements for Program Flash⁽¹⁾

		MIN	TYP	MAX	UNIT
$t_{prog(16-bit)}$	Half word (16-bit) programming time	4	16	200	μ s
$t_{prog(Total)}$	1M-byte programming time ⁽²⁾		8	32	s
$t_{erase(sector)}$	Sector erase time		1.7		s
t_{wec}	Write/erase cycles at $T_A = -40^\circ\text{C}$ to 85°C	50000			cycles
$t_{fp(\overline{RST})}$	Flash pump settling time from \overline{RST} to SLEEP		$167t_{c(SYS)}$		ns
$t_{fp(SLEEP)}$	Initial flash pump settling time from SLEEP to STANDBY		$167t_{c(SYS)}$		ns
$t_{fp(STANDBY)}$	Initial flash pump settling time from STANDBY to ACTIVE		$84t_{c(SYS)}$		ns

(1) For more detailed information on the flash core sectors, see the *flash program and erase* section of this data sheet.

(2) The 1M-byte programming time includes overhead of state machine.

SPIn MASTER MODE TIMING PARAMETERS

SPIn Master Mode External Timing Parameters

(CLOCK PHASE = 0, SPInCLK = output, SPInSIMO = output, and SPInSOMI = input)⁽¹⁾⁽²⁾⁽³⁾ (see Figure 13)

NO.			MIN	MAX	UNIT
1	$t_{c(SPC)M}$	Cycle time, SPInCLK ⁽⁴⁾	100	$256t_{c(ICLK)}$	ns
2(5)	$t_{w(SPCH)M}$	Pulse duration, SPInCLK high (clock polarity = 0)	$0.5t_{c(SPC)M} - t_r$	$0.5t_{c(SPC)M} + 5$	
	$t_{w(SPCL)M}$	Pulse duration, SPInCLK low (clock polarity = 1)	$0.5t_{c(SPC)M} - t_f$	$0.5t_{c(SPC)M} + 5$	
3(5)	$t_{w(SPCL)M}$	Pulse duration, SPInCLK low (clock polarity = 0)	$0.5t_{c(SPC)M} - t_f$	$0.5t_{c(SPC)M} + 5$	
	$t_{w(SPCH)M}$	Pulse duration, SPInCLK high (clock polarity = 1)	$0.5t_{c(SPC)M} - t_r$	$0.5t_{c(SPC)M} + 5$	
4(5)	$t_{d(SPCH-SIMO)M}$	Delay time, SPInCLK high to SPInSIMO valid (clock polarity = 0)		10	
	$t_{d(SPCL-SIMO)M}$	Delay time, SPInCLK low to SPInSIMO valid (clock polarity = 1)		10	
5(5)	$t_{v(SPCL-SIMO)M}$	Valid time, SPInSIMO data valid after SPInCLK low (clock polarity = 0)	$t_{c(SPC)M} - 5 - t_f$		
	$t_{v(SPCH-SIMO)M}$	Valid time, SPInSIMO data valid after SPInCLK high (clock polarity = 1)	$t_{c(SPC)M} - 5 - t_r$		
6(5)	$t_{su(SOMI-SPCL)M}$	Setup time, SPInSOMI before SPInCLK low (clock polarity = 0)	6		
	$t_{su(SOMI-SPCH)M}$	Setup time, SPInSOMI before SPInCLK high (clock polarity = 1)	6		
7(5)	$t_{v(SPCL-SOMI)M}$	Valid time, SPInSOMI data valid after SPInCLK low (clock polarity = 0)	4		
	$t_{v(SPCH-SOMI)M}$	Valid time, SPInSOMI data valid after SPInCLK high (clock polarity = 1)	4		

(1) The MASTER bit (SPInCTRL2.3) is set and the CLOCK PHASE bit (SPInCTRL2.0) is cleared.

(2) $t_{c(ICLK)}$ = interface clock cycle time = $1/f_{(ICLK)}$

(3) For rise and fall timings, see the "Switching Characteristics for Output Timings versus Load Capacitance" table.

(4) When the SPI is in master mode, the following must be true:

For PS values from 1 to 255: $t_{c(SPC)M} \geq (PS + 1)t_{c(ICLK)} \geq 100$ ns, where PS is the prescale value set in the SPInCTL1[12:5] register bits.

For PS values of 0: $t_{c(SPC)M} = 2t_{c(ICLK)} \geq 100$ ns.

(5) The active edge of the SPInCLK signal referenced is controlled by the CLOCK POLARITY bit (SPInCTRL2.1).

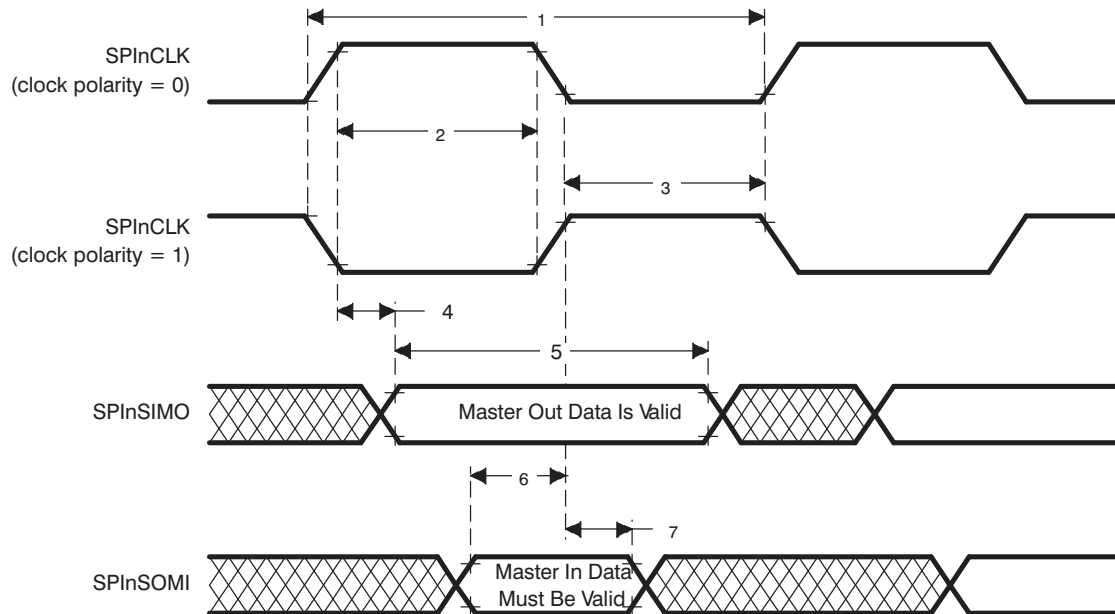

Figure 13. SPIn Master Mode External Timing (CLOCK PHASE = 0)

SPI_n Master Mode External Timing Parameters

(CLOCK PHASE = 1, SPInCLK = output, SPInSIMO = output, and SPInSOMI = input)⁽¹⁾⁽²⁾⁽³⁾ (see Figure 14)

NO.			MIN	MAX	UNIT
1	$t_{c(SPC)M}$	Cycle time, SPInCLK ⁽⁴⁾	100	$256t_{c(ICLK)}$	ns
2 ⁽⁵⁾	$t_{w(SPCH)M}$	Pulse duration, SPInCLK high (clock polarity = 0)	$0.5t_{c(SPC)M} - t_f$	$0.5t_{c(SPC)M} + 5$	
	$t_{w(SPCL)M}$	Pulse duration, SPInCLK low (clock polarity = 1)	$0.5t_{c(SPC)M} - t_f$	$0.5t_{c(SPC)M} + 5$	
3 ⁽⁵⁾	$t_{w(SPCL)M}$	Pulse duration, SPInCLK low (clock polarity = 0)	$0.5t_{c(SPC)M} - t_f$	$0.5t_{c(SPC)M} + 5$	
	$t_{w(SPCH)M}$	Pulse duration, SPInCLK high (clock polarity = 1)	$0.5t_{c(SPC)M} - t_f$	$0.5t_{c(SPC)M} + 5$	
4 ⁽⁵⁾	$t_{v(SIMO-SPCH)M}$	Valid time, SPInCLK high after SPInSIMO data valid (clock polarity = 0)	$0.5t_{c(SPC)M} - 10$		
	$t_{v(SIMO-SPCL)M}$	Valid time, SPInCLK low after SPInSIMO data valid (clock polarity = 1)	$0.5t_{c(SPC)M} - 10$		
5 ⁽⁵⁾	$t_{v(SPCH-SIMO)M}$	Valid time, SPInSIMO data valid after SPInCLK high (clock polarity = 0)	$0.5t_{c(SPC)M} - 5 - t_f$		
	$t_{v(SPCL-SIMO)M}$	Valid time, SPInSIMO data valid after SPInCLK low (clock polarity = 1)	$0.5t_{c(SPC)M} - 5 - t_f$		
6 ⁽⁵⁾	$t_{su(SOMI-SPCH)M}$	Setup time, SPInSOMI before SPInCLK high (clock polarity = 0)	6		
	$t_{su(SOMI-SPCL)M}$	Setup time, SPInSOMI before SPInCLK low (clock polarity = 1)	6		
7 ⁽⁵⁾	$t_{v(SPCH-SOMI)M}$	Valid time, SPInSOMI data valid after SPInCLK high (clock polarity = 0)	4		
	$t_{v(SPCL-SOMI)M}$	Valid time, SPInSOMI data valid after SPInCLK low (clock polarity = 1)	4		

- (1) The MASTER bit (SPInCTRL2.3) is set and the CLOCK PHASE bit (SPInCTRL2.0) is set.
- (2) $t_{c(ICLK)}$ = interface clock cycle time = $1/f_{ICLK}$
- (3) For rise and fall timings, see the "Switching Characteristics for Output Timings versus Load Capacitance" table.
- (4) When the SPI is in master mode, the following must be true:
For PS values from 1 to 255: $t_{c(SPC)M} \geq (PS + 1)t_{c(ICLK)} \geq 100$ ns, where PS is the prescale value set in the SPInCTL1[12:5] register bits.
For PS values of 0: $t_{c(SPC)M} = 2t_{c(ICLK)} \geq 100$ ns.
- (5) The active edge of the SPInCLK signal referenced is controlled by the CLOCK POLARITY bit (SPInCTRL2.1).

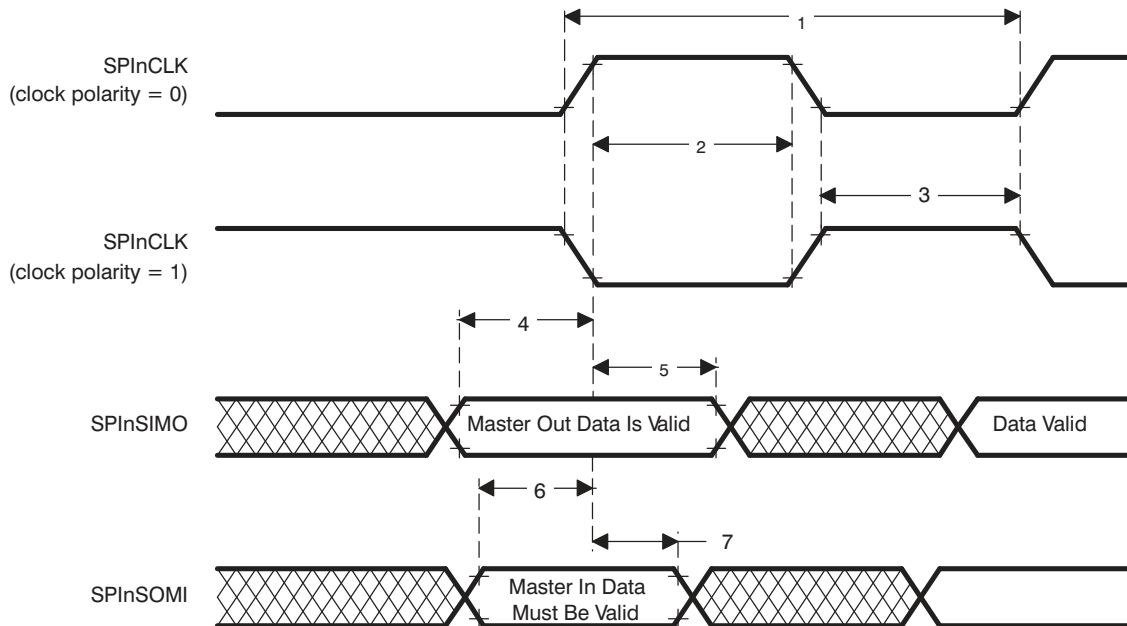

Figure 14. SPI_n Master Mode External Timing (CLOCK PHASE = 1)

SPIn SLAVE MODE TIMING PARAMETERS

SPIn Slave Mode External Timing Parameters

(CLOCK PHASE = 0, SPInCLK = input, SPInSIMO = input, and SPInSOMI = output)⁽¹⁾⁽²⁾⁽³⁾⁽⁴⁾ (see Figure 15)

NO.			MIN	MAX	UNIT
1	$t_{c(SPC)S}$	Cycle time, SPInCLK ⁽⁵⁾	100	$256t_{c(ICLK)}$	
2 ⁽⁶⁾	$t_{w(SPCH)S}$	Pulse duration, SPInCLK high (clock polarity = 0)	$0.5t_{c(SPC)S} - 0.25t_{c(ICLK)}$	$0.5t_{c(SPC)S} + 0.25t_{c(ICLK)}$	
	$t_{w(SPCL)S}$	Pulse duration, SPInCLK low (clock polarity = 1)	$0.5t_{c(SPC)S} - 0.25t_{c(ICLK)}$	$0.5t_{c(SPC)S} + 0.25t_{c(ICLK)}$	
3 ⁽⁶⁾	$t_{w(SPCL)S}$	Pulse duration, SPInCLK low (clock polarity = 0)	$0.5t_{c(SPC)S} - 0.25t_{c(ICLK)}$	$0.5t_{c(SPC)S} + 0.25t_{c(ICLK)}$	
	$t_{w(SPCH)S}$	Pulse duration, SPInCLK high (clock polarity = 1)	$0.5t_{c(SPC)S} - 0.25t_{c(ICLK)}$	$0.5t_{c(SPC)S} + 0.25t_{c(ICLK)}$	
4 ⁽⁶⁾	$t_{d(SPCH-SOMI)S}$	Delay time, SPInCLK high to SPInSOMI valid (clock polarity = 0)		$6 + t_r$	
	$t_{d(SPCL-SOMI)S}$	Delay time, SPInCLK low to SPInSOMI valid (clock polarity = 1)		$6 + t_r$	
5 ⁽⁶⁾	$t_{v(SPCH-SOMI)S}$	Valid time, SPInSOMI data valid after SPInCLK high (clock polarity = 0)	$t_{c(SPC)S} - 6 - t_r$		ns
	$t_{v(SPCL-SOMI)S}$	Valid time, SPInSOMI data valid after SPInCLK low (clock polarity = 1)	$t_{c(SPC)S} - 6 - t_r$		
6 ⁽⁶⁾	$t_{su(SIMO-SPCL)S}$	Setup time, SPInSIMO before SPInCLK low (clock polarity = 0)	6		
	$t_{su(SIMO-SPCH)S}$	Setup time, SPInSIMO before SPInCLK high (clock polarity = 1)	6		
7 ⁽⁶⁾	$t_{v(SPCL-SIMO)S}$	Valid time, SPInSIMO data valid after SPInCLK low (clock polarity = 0)	6		
	$t_{v(SPCH-SIMO)S}$	Valid time, SPInSIMO data valid after SPInCLK high (clock polarity = 1)	6		

- (1) The MASTER bit (SPInCTRL2.3) is cleared and the CLOCK PHASE bit (SPInCTRL2.0) is cleared.
- (2) If the SPI is in slave mode, the following must be true: $t_{c(SPC)S} \geq (PS + 1)t_{c(ICLK)}$, where PS = prescale value set in SPInCTL1[12:5].
- (3) For rise and fall timings, see the "Switching Characteristics for Output Timings versus Load Capacitance" table.
- (4) $t_{c(ICLK)}$ = interface clock cycle time = $1/f_{ICLK}$
- (5) When the SPIn is in slave mode, the following must be true:
 For PS values from 1 to 255: $t_{c(SPC)S} \geq (PS + 1)t_{c(ICLK)} \geq 100$ ns, where PS is the prescale value set in the SPInCTL1[12:5] register bits.
 For PS values of 0: $t_{c(SPC)S} = 2t_{c(ICLK)} \geq 100$ ns.
- (6) The active edge of the SPInCLK signal referenced is controlled by the CLOCK POLARITY bit (SPInCTRL2.1).

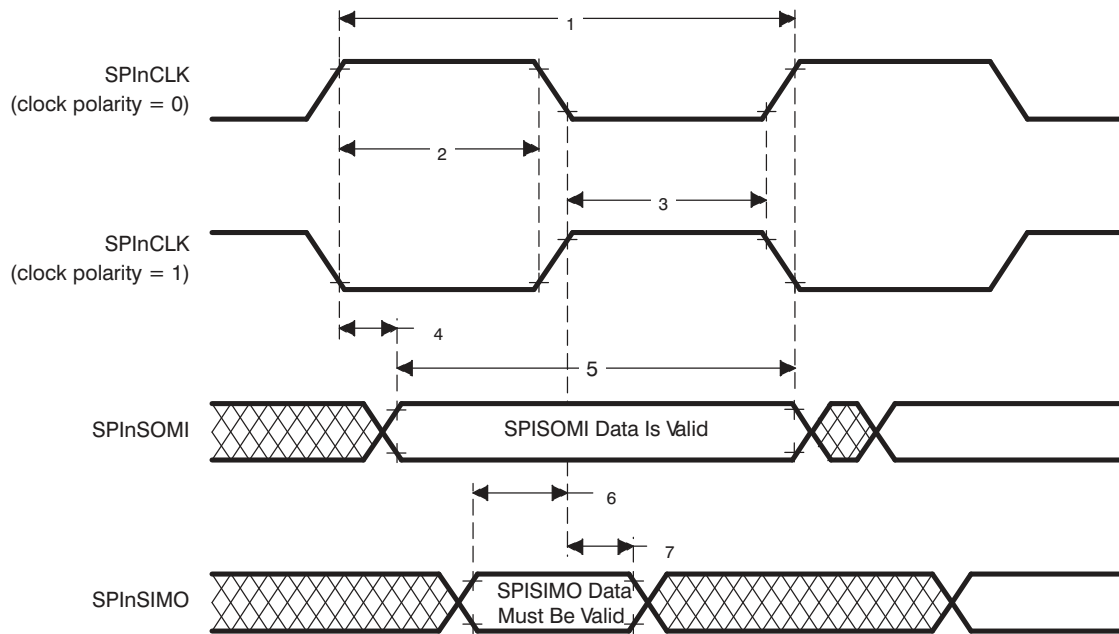

Figure 15. SPIn Slave Mode External Timing (CLOCK PHASE = 0)

SPIn Slave Mode External Timing Parameters

(CLOCK PHASE = 1, SPInCLK = input, SPInSIMO = input, and SPInSOMI = output) ⁽¹⁾⁽²⁾⁽³⁾⁽⁴⁾ (see Figure 16)

NO.		MIN	MAX	UNIT
1	$t_{c(SPC)S}$ Cycle time, SPInCLK ⁽⁵⁾	100	$256t_{c(ICLK)}$	ns
2 ⁽⁶⁾	$t_{w(SPCH)S}$ Pulse duration, SPInCLK high (clock polarity = 0)	$0.5t_{c(SPC)S} - 0.25t_{c(ICLK)}$	$0.5t_{c(SPC)S} + 0.25t_{c(ICLK)}$	
	$t_{w(SPCL)S}$ Pulse duration, SPInCLK low (clock polarity = 1)	$0.5t_{c(SPC)S} - 0.25t_{c(ICLK)}$	$0.5t_{c(SPC)S} + 0.25t_{c(ICLK)}$	
3 ⁽⁶⁾	$t_{w(SPCL)S}$ Pulse duration, SPInCLK low (clock polarity = 0)	$0.5t_{c(SPC)S} - 0.25t_{c(ICLK)}$	$0.5t_{c(SPC)S} + 0.25t_{c(ICLK)}$	
	$t_{w(SPCH)S}$ Pulse duration, SPInCLK high (clock polarity = 1)	$0.5t_{c(SPC)S} - 0.25t_{c(ICLK)}$	$0.5t_{c(SPC)S} + 0.25t_{c(ICLK)}$	
4 ⁽⁶⁾	$t_{v(SOMI-SPCH)S}$ Valid time, SPInCLK high after SPInSOMI data valid (clock polarity = 0)	$0.5t_{c(SPC)S} - 6 - t_r$		
	$t_{v(SOMI-SPCL)S}$ Valid time, SPInCLK low after SPInSOMI data valid (clock polarity = 1)	$0.5t_{c(SPC)S} - 6 - t_f$		
5 ⁽⁶⁾	$t_{v(SPCH-SOMI)S}$ Valid time, SPInSOMI data valid after SPInCLK high (clock polarity = 0)	$0.5t_{c(SPC)S} - 6 - t_r$		
	$t_{v(SPCL-SOMI)S}$ Valid time, SPInSOMI data valid after SPInCLK low (clock polarity = 1)	$0.5t_{c(SPC)S} - 6 - t_f$		
6 ⁽⁶⁾	$t_{su(SIMO-SPCH)S}$ Setup time, SPInSIMO before SPInCLK high (clock polarity = 0)	6		
	$t_{su(SIMO-SPCL)S}$ Setup time, SPInSIMO before SPInCLK low (clock polarity = 1)	6		
7 ⁽⁶⁾	$t_{v(SPCH-SIMO)S}$ Valid time, SPInSIMO data valid after SPInCLK high (clock polarity = 0)	6		
	$t_{v(SPCL-SIMO)S}$ Valid time, SPInSIMO data valid after SPInCLK low (clock polarity = 1)	6		

- (1) The MASTER bit (SPInCTRL2.3) is cleared and the CLOCK PHASE bit (SPInCTRL2.0) is set.
- (2) If the SPI is in slave mode, the following must be true: $t_{c(SPC)S} \geq (PS + 1) t_{c(ICLK)}$, where PS = prescale value set in SPInCTL1[12:5].
- (3) For rise and fall timings, see the "Switching Characteristics for Output Timings versus Load Capacitance" table.
- (4) $t_{c(ICLK)}$ = interface clock cycle time = $1/f_{(ICLK)}$
- (5) When the SPIn is in slave mode, the following must be true:
For PS values from 1 to 255: $t_{c(SPC)S} \geq (PS + 1)t_{c(ICLK)} \geq 100$ ns, where PS is the prescale value set in the SPInCTL1[12:5] register bits.
For PS values of 0: $t_{c(SPC)S} = 2t_{c(ICLK)} \geq 100$ ns.
- (6) The active edge of the SPInCLK signal referenced is controlled by the CLOCK POLARITY bit (SPInCTRL2.1).

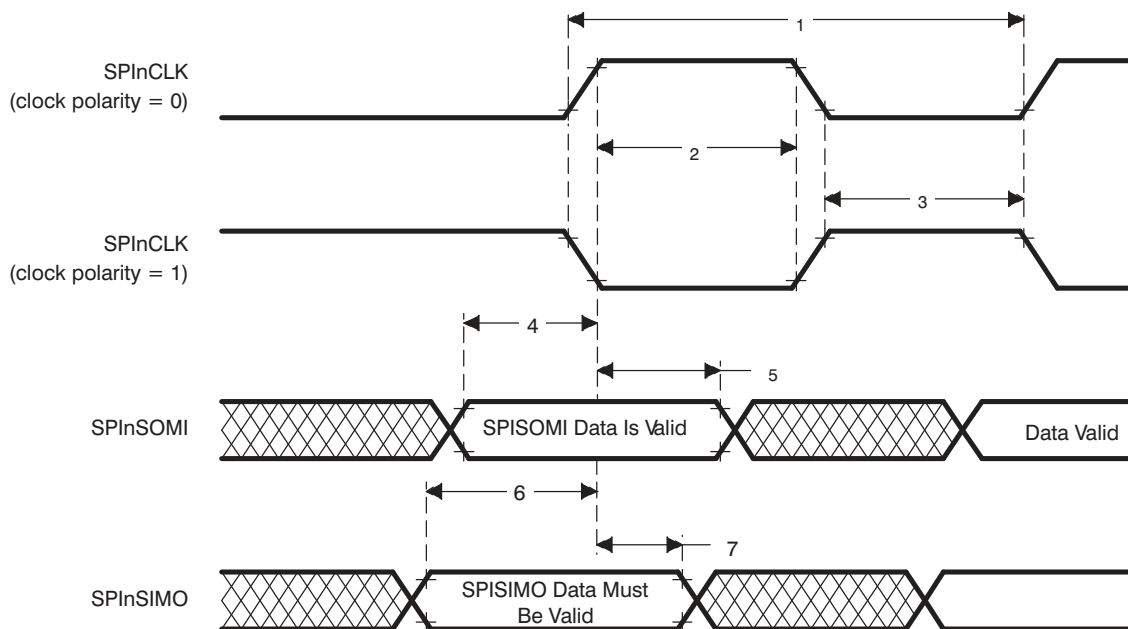

Figure 16. SPIn Slave Mode External Timing (CLOCK PHASE = 1)

SCI_n ISOSYNCHRONOUS MODE TIMINGS - INTERNAL CLOCK

Timing Requirements for Internal Clock SCI_n Isosynchronous Mode⁽¹⁾⁽²⁾⁽³⁾

(see Figure 17)

		(BAUD + 1) IS EVEN OR BAUD = 0		(BAUD + 1) IS ODD AND BAUD ≠ 0		UNIT
		MIN	MAX	MIN	MAX	
$t_{c(SCC)}$	Cycle time, SCInCLK	$2t_{c(ICKL)}$	$2^{24} t_{c(ICKL)}$	$3t_{c(ICKL)}$	$(2^{24} - 1) t_{c(ICKL)}$	ns
$t_w(SCCL)$	Pulse duration, SCInCLK low	$0.5t_{c(SCC)} - t_f$	$0.5t_{c(SCC)} + 5$	$0.5t_{c(SCC)} + 0.5t_{c(ICKL)} - t_f$	$0.5t_{c(SCC)} + 0.5t_{c(ICKL)}$	ns
$t_w(SCCH)$	Pulse duration, SCInCLK high	$0.5t_{c(SCC)} - t_f$	$0.5t_{c(SCC)} + 5$	$0.5t_{c(SCC)} - 0.5t_{c(ICKL)} - t_f$	$0.5t_{c(SCC)} - 0.5t_{c(ICKL)}$	ns
$t_d(SCCH-TXV)$	Delay time, SCInCLK high to SCInTX valid		10		10	ns
$t_v(TX)$	Valid time, SCInTX data after SCInCLK low	$t_{c(SCC)} - 10$		$t_{c(SCC)} - 10$		ns
$t_{su}(RX-SCCL)$	Setup time, SCInRX before SCInCLK low	$t_{c(ICKL)} + t_f + 20$		$t_{c(ICKL)} + t_f + 20$		ns
$t_v(SCCL-RX)$	Valid time, SCInRX data after SCInCLK low	$-t_{c(ICKL)} + t_f + 20$		$-t_{c(ICKL)} + t_f + 20$		ns

(1) BAUD = 24-bit concatenated value formed by the SCI[H,M,L]BAUD registers.

(2) $t_{c(ICKL)}$ = interface clock cycle time = $1/f_{(ICKL)}$

(3) For rise and fall timings, see the "switching characteristics for output timings versus load capacitance" table.

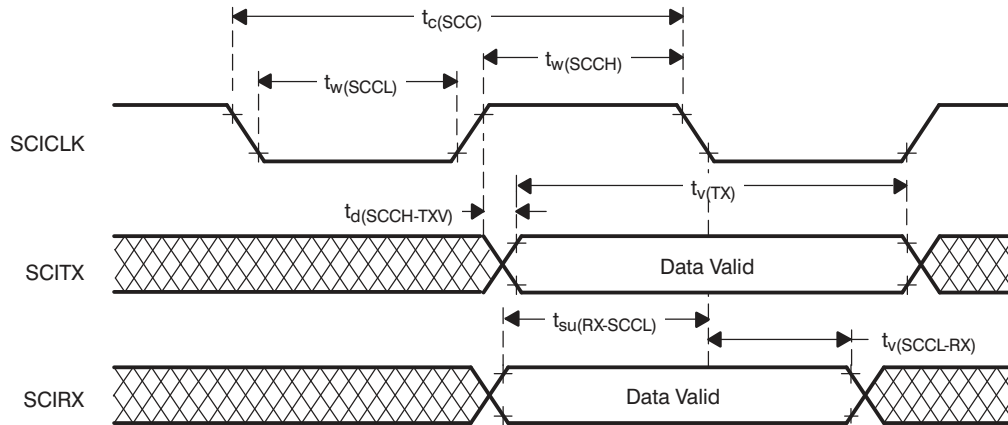

A. Data transmission/reception characteristics for isosynchronous mode with internal clocking are similar to the asynchronous mode. Data transmission occurs on the SCICLK rising edge, and data reception occurs on the SCICLK falling edge.

Figure 17. SCI_n Isosynchronous Mode Timing Diagram for Internal Clock

SCIn ISOSYNCHRONOUS MODE TIMINGS - EXTERNAL CLOCK

Timing Requirements for External Clock SCIn Isosynchronous Mode⁽¹⁾⁽²⁾

(see Figure 18)

		MIN	MAX	UNIT
$t_{c(SCC)}$	Cycle time, SCInCLK ⁽³⁾	$8t_{c(ICLK)}$		ns
$t_{w(SCCH)}$	Pulse duration, SCInCLK high	$0.5t_{c(SCC)} - 0.25t_{c(ICLK)}$	$0.5t_{c(SCC)} + 0.25t_{c(ICLK)}$	ns
$t_{w(SCCL)}$	Pulse duration, SCInCLK low	$0.5t_{c(SCC)} - 0.25t_{c(ICLK)}$	$0.5t_{c(SCC)} + 0.25t_{c(ICLK)}$	ns
$t_{d(SCCH-TXV)}$	Delay time, SCInCLK high to SCInTX valid		$2t_{c(ICLK)} + 12 + t_r$	ns
$t_{v(TX)}$	Valid time, SCInTX data after SCInCLK low	$2t_{c(SCC)} - 10$		ns
$t_{su(RX-SCCL)}$	Setup time, SCInRX before SCInCLK low	0		ns
$t_{v(SCCL-RX)}$	Valid time, SCInRX data after SCInCLK low	$2t_{c(ICLK)} + 10$		ns

(1) $t_{c(ICLK)}$ = interface clock cycle time = $1/f_{(ICLK)}$

(2) For rise and fall timings, see the "switching characteristics for output timings versus load capacitance" table.

(3) When driving an external SCInCLK, the following must be true: $t_{c(SCC)} \geq 8t_{c(ICLK)}$.

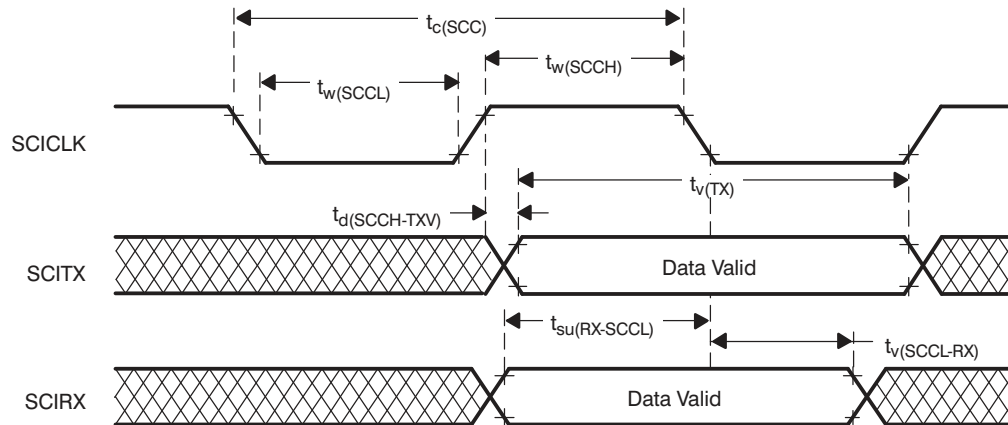

- A. Data transmission / reception characteristics for isosynchronous mode with external clocking are similar to the asynchronous mode. Data transmission occurs on the SCICLK rising edge, and data reception occurs on the SCICLK falling edge.

Figure 18. SCIn Isosynchronous Mode Timing Diagram for External Clock

STANDARD CAN CONTROLLER (SCC) MODE TIMINGS

Dynamic Characteristics for the CANSTX and CANSRX Pins

PARAMETER		MIN	MAX	UNIT
$t_d(\text{CANSTX})$	Delay time, transmit shift register to CANSTX pin ⁽¹⁾		15	ns
$t_d(\text{CANSRX})$	Delay time, CANSRX pin to receive shift register		5	ns

(1) These values do not include the rise/fall times of the output buffer.

EXPANSION BUS MODULE TIMING

Expansion Bus Timing Parameters

−40°C ≤ T_j ≤ 150°C, 3.0 V ≤ V_{CC} ≤ 3.6 V (see Figure 20 and Figure 21)

		MIN	MAX	UNIT
t _{c(CO)}	Cycle time, CLKOUT	20.8		ns
t _{d(COH-EBADV)}	Delay time, CLKOUT high to EBADDR valid		21.4	ns
t _{h(COH-EBADIV)}	Hold time, EBADDR invalid after CLKOUT high		12.4	ns
t _{d(COH-EBOE)}	Delay time, CLKOUT high to $\overline{\text{EBOE}}$ fall		11.4	ns
t _{h(COH-EBOEH)}	Hold time, $\overline{\text{EBOE}}$ rise after CLKOUT high		11.4	ns
t _{d(COL-EBWR)}	Delay time, CLKOUT low to write strobe ($\overline{\text{EBWR}}$) low		11.3	ns
t _{h(COL-EBWRH)}	Hold time, $\overline{\text{EBWR}}$ high after CLKOUT low		11.6	ns
t _{su(EBRDATV-COH)}	Setup time, EBDATA valid before CLKOUT high (READ) ⁽¹⁾	15.2		ns
t _{h(COH-EBRDATIV)}	Hold time, EBDATA invalid after CLKOUT high (READ)		(−14.7)	ns
t _{d(COL-EBWDATV)}	Delay time, CLKOUT low to EBDATA valid (WRITE) ⁽²⁾		16.1	ns
t _{h(COL-EBWDATIV)}	Hold time, EBDATA invalid after CLKOUT low (WRITE)		14.7	ns
SECONDARY TIMES				
t _{d(COH-EBCS0)}	Delay, CLKOUT high to $\overline{\text{EBCS0}}$ fall		13.6	ns
t _{h(COH-EBCS0H)}	Hold, $\overline{\text{EBCS0}}$ rise after CLKOUT high		13.2	ns
t _{su(COH-EBHOLDL)}	Setup time, $\overline{\text{EBHOLD}}$ low to CLKOUT high ⁽¹⁾	10.9		ns
t _{su(COH-EBHOLDH)}	Setup time, $\overline{\text{EBHOLD}}$ high to CLKOUT high ⁽¹⁾	10.5		ns

- (1) Setup time is the minimum time under worst case conditions. Data with less setup time will not work.
- (2) Valid after CLKOUT goes low for write cycles.

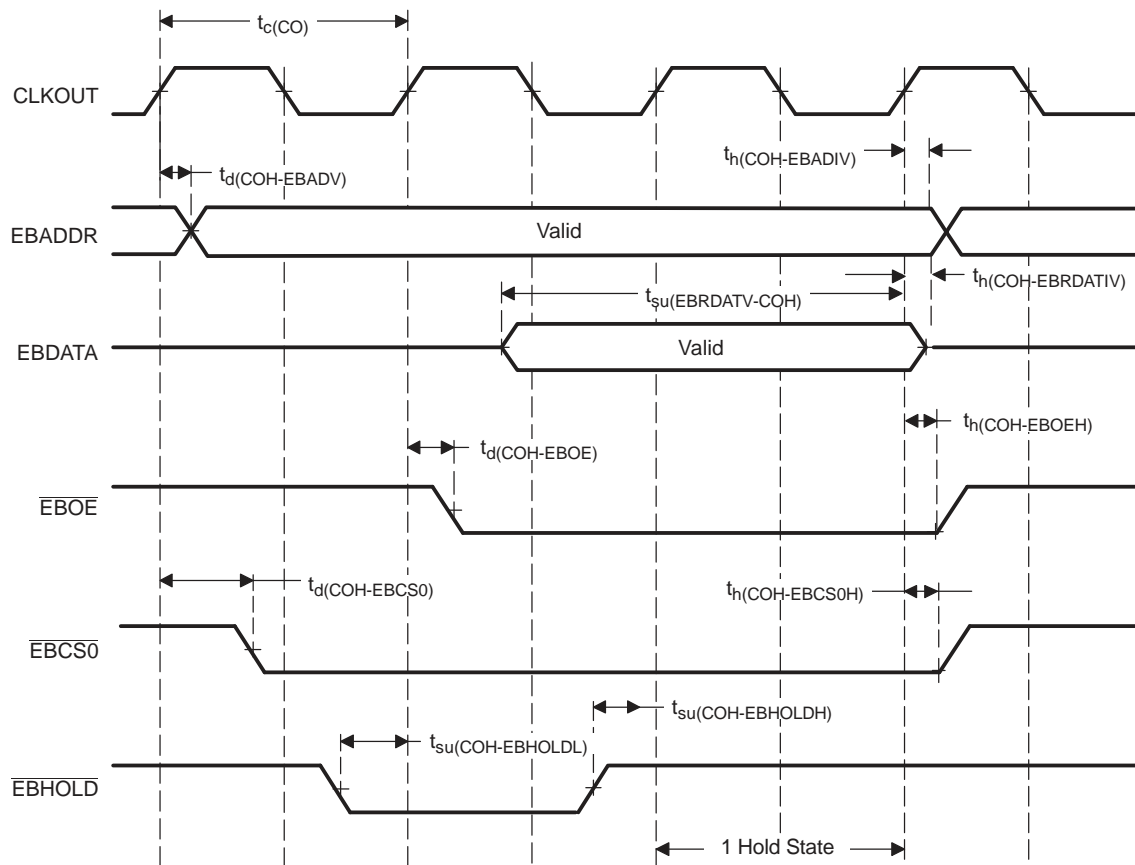

Figure 20. Expansion Memory Signal Timing - Reads

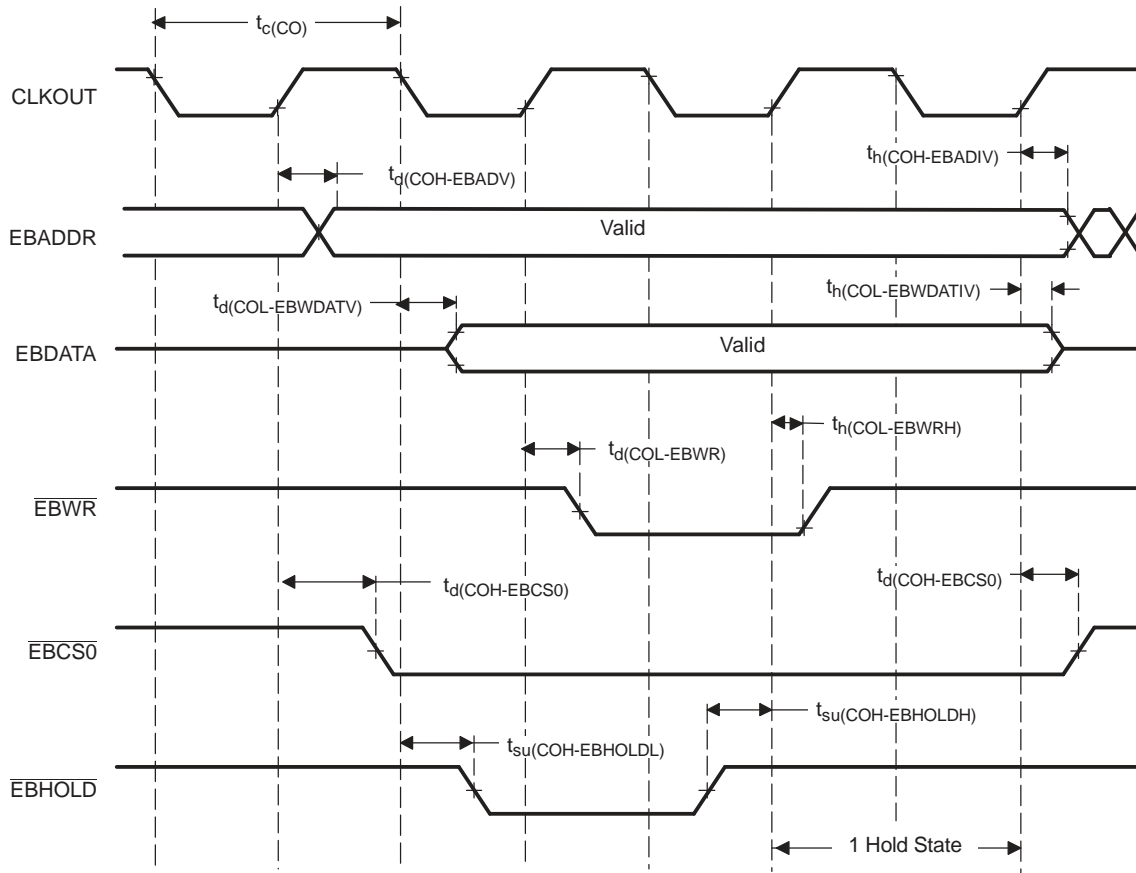

Figure 21. Expansion Memory Signal Timing - Writes

HIGH-END TIMER (HET) TIMINGS

Minimum PWM Output Pulse Width:

This is equal to one high resolution clock period (HRP). The HRP is defined by the 6-bit high resolution prescale factor (hr), which is user defined, giving prescale factors of 1 to 64, with a linear increment of codes.

Therefore, the minimum PWM output pulse width = $HRP(\min) = hr(\min)/SYSCLK = 1/SYSCLK$

For example, for a SYSCLK of 30 MHz, the minimum PWM output pulse width = $1/30 = 33.33\text{ns}$

Minimum Input Pulses that Can Be Captured:

The input pulse width must be greater or equal to the low resolution clock period (LRP), i.e., the HET loop (the HET program must fit within the LRP). The LRP is defined by the 3-bit loop-resolution prescale factor (lr), which is user defined, with a power of 2 increment of codes. That is, the value of lr can be 1, 2, 4, 8, 16, or 32.

Therefore, the minimum input pulse width = $LRP(\min) = hr(\min) * lr(\min)/SYSCLK = 1 * 1/SYSCLK$

For example, with a SYSCLK of 30 MHz, the minimum input pulse width = $1 * 1/30 = 33.33 \text{ ns}$

NOTE:

Once the input pulse width is greater than LRP, the resolution of the measurement is still HRP. (That is, the captured value gives the number of HRP clocks inside the pulse.)

Abbreviations:

hr = HET high resolution divide rate = 1, 2, 3,...63, 64

lr = HET low resolution divide rate = 1, 2, 4, 8, 16, 32

High resolution clock period = $HRP = hr/SYSCLK$

Loop resolution clock period = $LRP = hr*lr/SYSCLK$

MULTI-BUFFERED A-TO-D CONVERTER (MibADC)

The multi-buffered A-to-D converter (MibADC) has a separate power bus for its analog circuitry that enhances the A-to-D performance by preventing digital switching noise on the logic circuitry, which could be present on V_{SS} and V_{CC}, from coupling into the A-to-D analog stage. All A-to-D specifications are given with respect to AD_{REFLO} unless otherwise noted.

Resolution	10 bits (1024 values)
Monotonic	Assured
Output conversion code	00h to 3FFh [00 for V _{AI} ≤ AD _{REFLO} ; 3FF for V _{AI} ≥ AD _{REFHI}]

Table 17. MibADC Recommended Operating Conditions⁽¹⁾

		MIN	MAX	UNIT
AD _{REFHI}	A-to-D high-voltage reference source	V _{SSAD}	V _{CCAD}	V
AD _{REFLO}	A-to-D low-voltage reference source	V _{SSAD}	V _{CCAD}	V
V _{AI}	Analog input voltage	V _{SSAD} - 0.3	V _{CCAD} + 0.3	V
I _{AIC}	Analog input clamp current ⁽²⁾ (V _{AI} < V _{SSAD} - 0.3 or V _{AI} > V _{CCAD} + 0.3)	-2	2	mA

- (1) For V_{CCAD} and V_{SSAD} recommended operating conditions, see the "Device Recommended Operating Conditions" table.
(2) Input currents into any ADC input channel outside the specified limits could affect conversion results of other channels.

Table 18. Operating Characteristics over Full Ranges of Recommended Operating Conditions⁽¹⁾⁽²⁾

PARAMETER	DESCRIPTION/CONDITIONS	MIN	TYP	MAX	UNIT	
R _I	Analog input resistance	See Figure 22 .		250	500	Ω
C _I	Analog input capacitance	See Figure 22 .			10	pF
		Conversion			30	pF
I _{AIL}	Analog input leakage current	See Figure 22 .		-1	1	μA
I _{ADREFHI}	AD _{REFHI} input current	AD _{REFHI} = 3.6 V, AD _{REFLO} = V _{SSAD}			5	mA
CR	Conversion range over which specified accuracy is maintained	AD _{REFHI} - AD _{REFLO}		3	3.6	V
E _{DNL}	Differential nonlinearity error	Difference between the actual step width and the ideal value. See Figure 23 .			±1.5	LSB
E _{INL}	Integral nonlinearity error	Maximum deviation from the best straight line through the MibADC. MibADC transfer characteristics, excluding the quantization error. See Figure 24 .			±2	LSB
E _{TOT}	Total error/Absolute accuracy	Maximum value of the difference between an analog value and the ideal midstep value. See Figure 25 .			±2	LSB

- (1) V_{CCAD} = AD_{REFHI}
(2) 1 LSB = (AD_{REFHI} - AD_{REFLO})/2¹⁰ for the MibADC

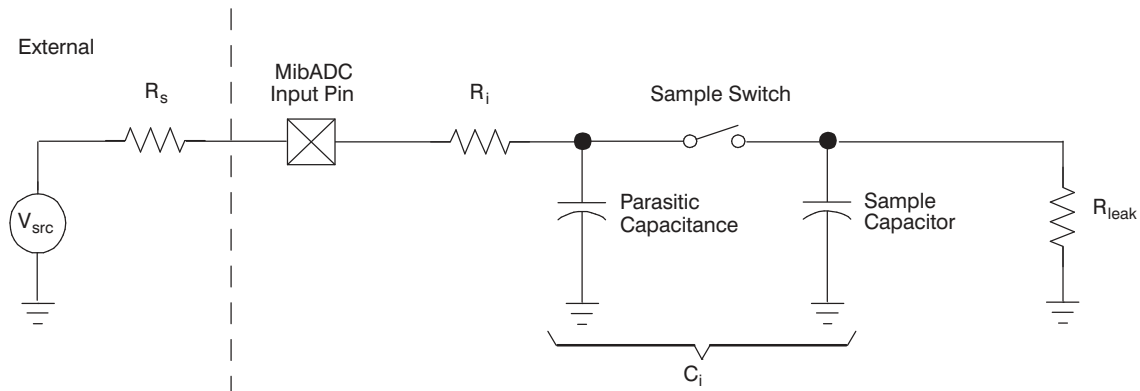

Figure 22. MibADC Input Equivalent Circuit

Table 19. Multi-Buffer ADC Timing Requirements

		MIN	NOM	MAX	UNIT
$t_{c(ADCLK)}$	Cycle time, MibADC clock	0.05			μs
$t_{d(SH)}$	Delay time, sample and hold time	1			μs
$t_{d(\odot)}$	Delay time, conversion time	0.55			μs
$t_{d(SHC)}^{(1)}$	Delay time, total sample/hold and conversion time	1.55			μs

(1) This is the minimum sample/hold and conversion time that can be achieved. These parameters are dependent on many factors; for more details, see the *TMS470R1x Multi-Buffered Analog-to-Digital Converter (MibADC) Reference Guide* (literature number SPNU206).

The differential nonlinearity error shown in [Figure 23](#) (sometimes referred to as differential linearity) is the difference between an actual step width and the ideal value of 1 LSB.

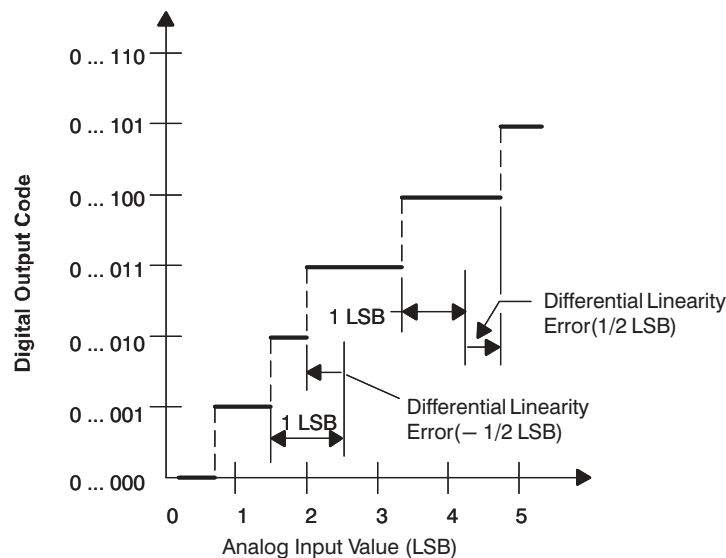

A. $1 \text{ LSB} = (AD_{REFHI} - AD_{REFLO})/2^{10}$

Figure 23. Differential Nonlinearity (DNL)

The integral nonlinearity error shown in Figure 24 (sometimes referred to as linearity error) is the deviation of the values on the actual transfer function from a straight line.

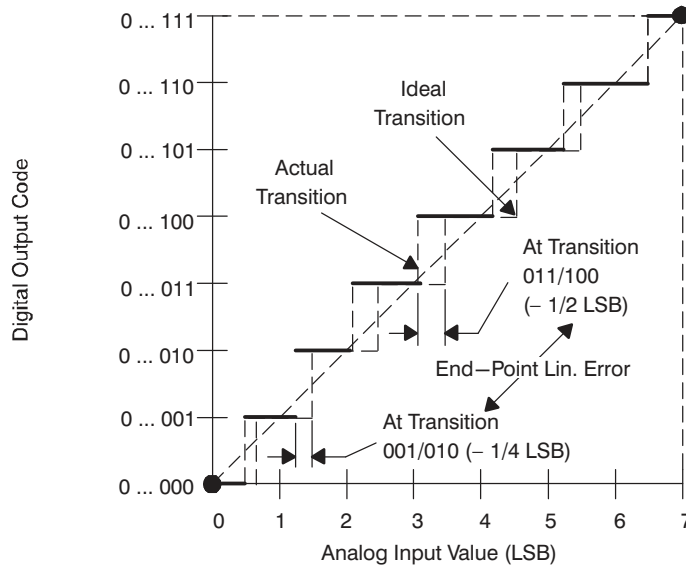

A. $1 \text{ LSB} = (AD_{\text{REFHI}} - AD_{\text{REFLO}})/2^{10}$

Figure 24. Integral Nonlinearity (INL) Error

The absolute accuracy or total error of an MibADC as shown in Figure 25 is the maximum value of the difference between an analog value and the ideal midstep value.

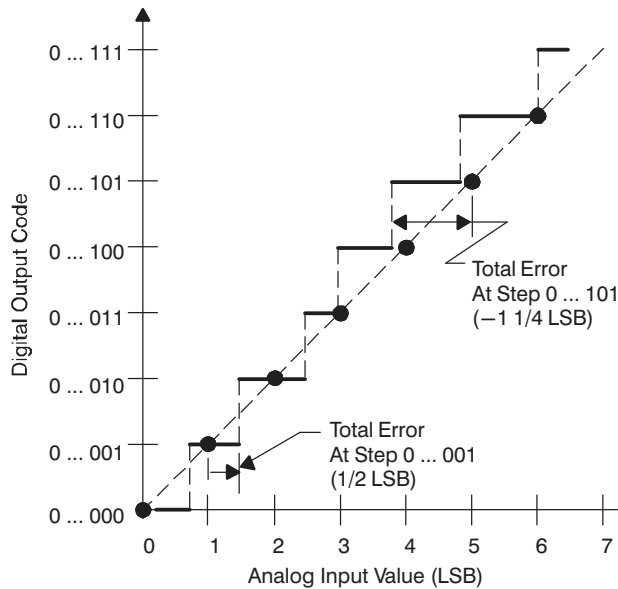

A. $1 \text{ LSB} = (AD_{\text{REFHI}} - AD_{\text{REFLO}})/2^{10}$

Figure 25. Absolute Accuracy (Total) Error

TMS470R1B1M
16/32-Bit RISC Flash Microcontroller

SPNS109A—SEPTEMBER 2005—REVISED AUGUST 2006

Thermal Resistance Characteristics

PARAMETER	°C/W
$R_{\theta JA}$	43
$R_{\theta JC}$	5

Revision History

This revision history highlights the changes made to the device-specific datasheet SPNS109.

Table 12. Revision History

SPNS109 to SPNS109A
Added note to $\overline{\text{PORRST}}$ Timing Diagram.
Changed T_A range to -40°C to 85°C on t_{wec} in "Timing Requirements for Program Flash" table.
Changed t_{wec} MIN value to 50000 and deleted TYP value in "Timing Requirements for Program Flash" table.
Changed $t_{\text{erase(sector)}}$ TYP value to 1.7 in "Timing Requirements for Program Flash" table.

PACKAGING INFORMATION

Orderable Device	Status ⁽¹⁾	Package Type	Package Drawing	Pins	Package Qty	Eco Plan ⁽²⁾	Lead/Ball Finish	MSL Peak Temp ⁽³⁾
TMS470R1B1MPGEA	NRND	LQFP	PGE	144	60	Green (RoHS & no Sb/Br)	CU NIPDAU	Level-3-260C-168 HR
TMS470R1B1MPGEAR	NRND	LQFP	PGE	144	500	Green (RoHS & no Sb/Br)	CU NIPDAU	Level-3-260C-168 HR

⁽¹⁾ The marketing status values are defined as follows:

ACTIVE: Product device recommended for new designs.

LIFEBUY: TI has announced that the device will be discontinued, and a lifetime-buy period is in effect.

NRND: Not recommended for new designs. Device is in production to support existing customers, but TI does not recommend using this part in a new design.

PREVIEW: Device has been announced but is not in production. Samples may or may not be available.

OBsolete: TI has discontinued the production of the device.

⁽²⁾ Eco Plan - The planned eco-friendly classification: Pb-Free (RoHS), Pb-Free (RoHS Exempt), or Green (RoHS & no Sb/Br) - please check <http://www.ti.com/productcontent> for the latest availability information and additional product content details.

TBD: The Pb-Free/Green conversion plan has not been defined.

Pb-Free (RoHS): TI's terms "Lead-Free" or "Pb-Free" mean semiconductor products that are compatible with the current RoHS requirements for all 6 substances, including the requirement that lead not exceed 0.1% by weight in homogeneous materials. Where designed to be soldered at high temperatures, TI Pb-Free products are suitable for use in specified lead-free processes.

Pb-Free (RoHS Exempt): This component has a RoHS exemption for either 1) lead-based flip-chip solder bumps used between the die and package, or 2) lead-based die adhesive used between the die and leadframe. The component is otherwise considered Pb-Free (RoHS compatible) as defined above.

Green (RoHS & no Sb/Br): TI defines "Green" to mean Pb-Free (RoHS compatible), and free of Bromine (Br) and Antimony (Sb) based flame retardants (Br or Sb do not exceed 0.1% by weight in homogeneous material)

⁽³⁾ MSL, Peak Temp. -- The Moisture Sensitivity Level rating according to the JEDEC industry standard classifications, and peak solder temperature.

Important Information and Disclaimer: The information provided on this page represents TI's knowledge and belief as of the date that it is provided. TI bases its knowledge and belief on information provided by third parties, and makes no representation or warranty as to the accuracy of such information. Efforts are underway to better integrate information from third parties. TI has taken and continues to take reasonable steps to provide representative and accurate information but may not have conducted destructive testing or chemical analysis on incoming materials and chemicals. TI and TI suppliers consider certain information to be proprietary, and thus CAS numbers and other limited information may not be available for release.

In no event shall TI's liability arising out of such information exceed the total purchase price of the TI part(s) at issue in this document sold by TI to Customer on an annual basis.

PGE (S-PQFP-G144)

PLASTIC QUAD FLATPACK

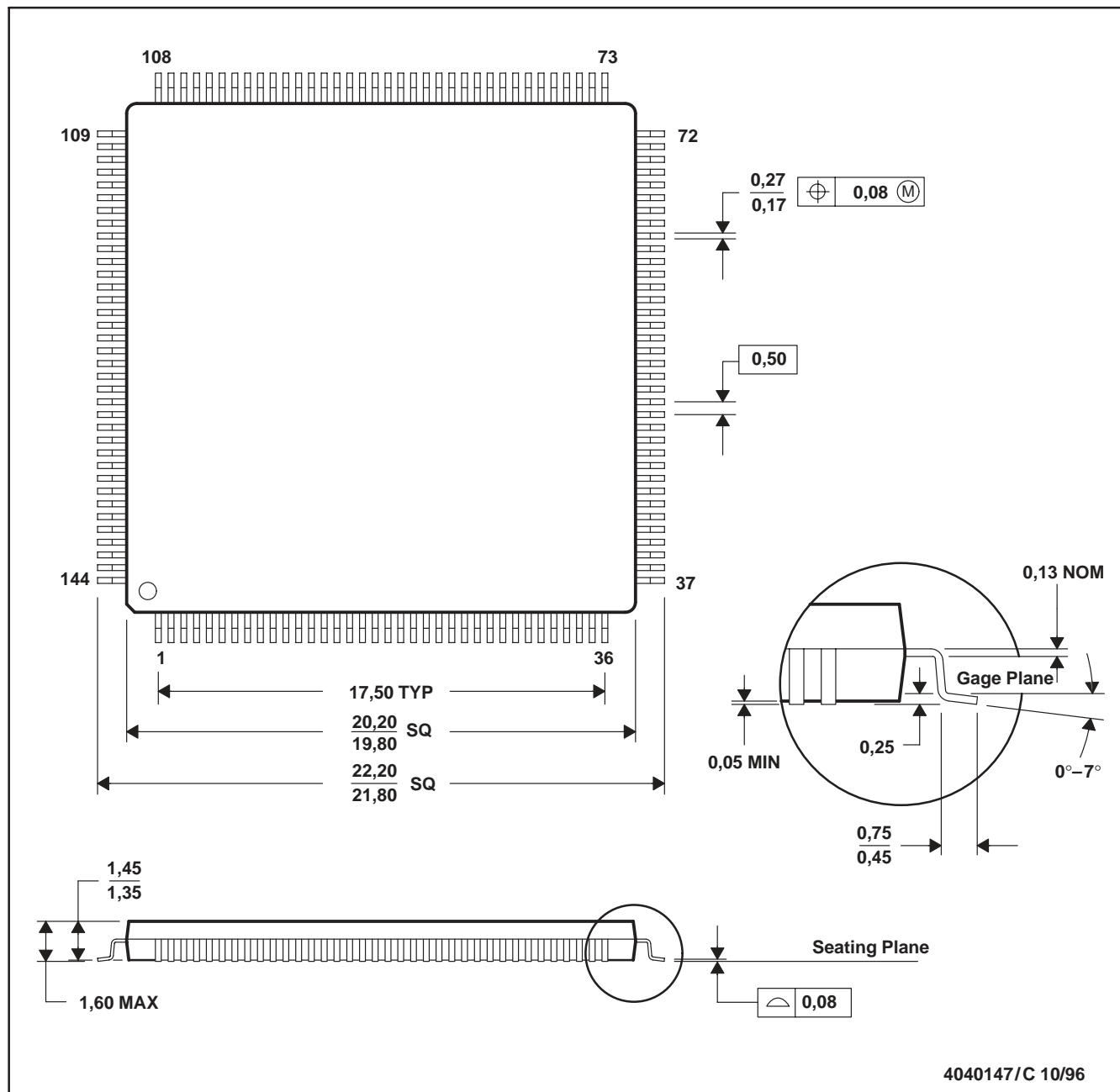

- NOTES: A. All linear dimensions are in millimeters.
 B. This drawing is subject to change without notice.
 C. Falls within JEDEC MS-026

IMPORTANT NOTICE

Texas Instruments Incorporated and its subsidiaries (TI) reserve the right to make corrections, modifications, enhancements, improvements, and other changes to its products and services at any time and to discontinue any product or service without notice. Customers should obtain the latest relevant information before placing orders and should verify that such information is current and complete. All products are sold subject to TI's terms and conditions of sale supplied at the time of order acknowledgment.

TI warrants performance of its hardware products to the specifications applicable at the time of sale in accordance with TI's standard warranty. Testing and other quality control techniques are used to the extent TI deems necessary to support this warranty. Except where mandated by government requirements, testing of all parameters of each product is not necessarily performed.

TI assumes no liability for applications assistance or customer product design. Customers are responsible for their products and applications using TI components. To minimize the risks associated with customer products and applications, customers should provide adequate design and operating safeguards.

TI does not warrant or represent that any license, either express or implied, is granted under any TI patent right, copyright, mask work right, or other TI intellectual property right relating to any combination, machine, or process in which TI products or services are used. Information published by TI regarding third-party products or services does not constitute a license from TI to use such products or services or a warranty or endorsement thereof. Use of such information may require a license from a third party under the patents or other intellectual property of the third party, or a license from TI under the patents or other intellectual property of TI.

Reproduction of TI information in TI data books or data sheets is permissible only if reproduction is without alteration and is accompanied by all associated warranties, conditions, limitations, and notices. Reproduction of this information with alteration is an unfair and deceptive business practice. TI is not responsible or liable for such altered documentation. Information of third parties may be subject to additional restrictions.

Resale of TI products or services with statements different from or beyond the parameters stated by TI for that product or service voids all express and any implied warranties for the associated TI product or service and is an unfair and deceptive business practice. TI is not responsible or liable for any such statements.

TI products are not authorized for use in safety-critical applications (such as life support) where a failure of the TI product would reasonably be expected to cause severe personal injury or death, unless officers of the parties have executed an agreement specifically governing such use. Buyers represent that they have all necessary expertise in the safety and regulatory ramifications of their applications, and acknowledge and agree that they are solely responsible for all legal, regulatory and safety-related requirements concerning their products and any use of TI products in such safety-critical applications, notwithstanding any applications-related information or support that may be provided by TI. Further, Buyers must fully indemnify TI and its representatives against any damages arising out of the use of TI products in such safety-critical applications.

TI products are neither designed nor intended for use in military/aerospace applications or environments unless the TI products are specifically designated by TI as military-grade or "enhanced plastic." Only products designated by TI as military-grade meet military specifications. Buyers acknowledge and agree that any such use of TI products which TI has not designated as military-grade is solely at the Buyer's risk, and that they are solely responsible for compliance with all legal and regulatory requirements in connection with such use.

TI products are neither designed nor intended for use in automotive applications or environments unless the specific TI products are designated by TI as compliant with ISO/TS 16949 requirements. Buyers acknowledge and agree that, if they use any non-designated products in automotive applications, TI will not be responsible for any failure to meet such requirements.

Following are URLs where you can obtain information on other Texas Instruments products and application solutions:

Products

Amplifiers	amplifier.ti.com
Data Converters	dataconverter.ti.com
DLP® Products	www.dlp.com
DSP	dsp.ti.com
Clocks and Timers	www.ti.com/clocks
Interface	interface.ti.com
Logic	logic.ti.com
Power Mgmt	power.ti.com
Microcontrollers	microcontroller.ti.com
RFID	www.ti-rfid.com
RF/IF and ZigBee® Solutions	www.ti.com/lprf

Applications

Audio	www.ti.com/audio
Automotive	www.ti.com/automotive
Broadband	www.ti.com/broadband
Digital Control	www.ti.com/digitalcontrol
Medical	www.ti.com/medical
Military	www.ti.com/military
Optical Networking	www.ti.com/opticalnetwork
Security	www.ti.com/security
Telephony	www.ti.com/telephony
Video & Imaging	www.ti.com/video
Wireless	www.ti.com/wireless

Mailing Address: Texas Instruments, Post Office Box 655303, Dallas, Texas 75265
Copyright © 2009, Texas Instruments Incorporated