

REV.	DATE	ECR NO.	DESCRIPTION
A	02/10/10	XXXXXX	UPDATE DRAWING FORMAT

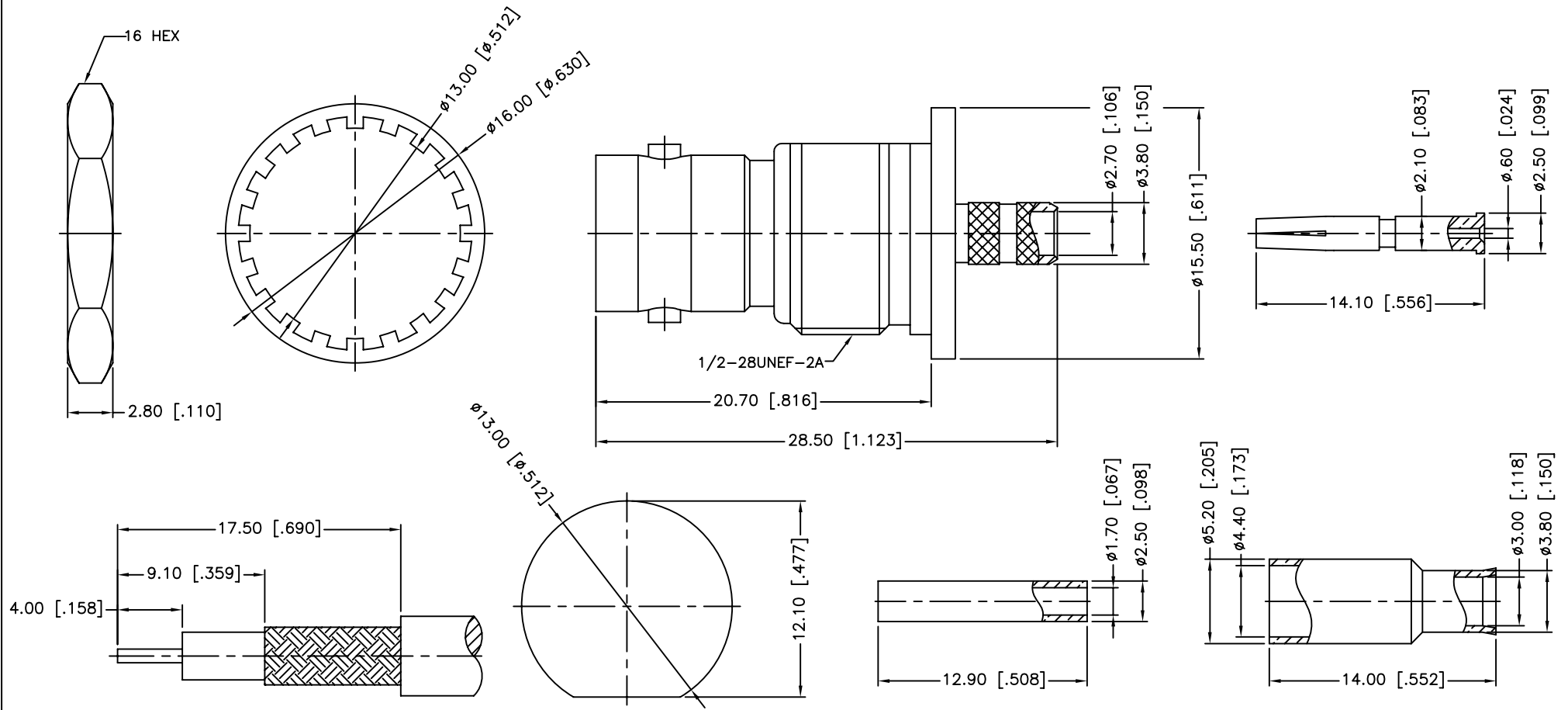

RECOMMENDED
CABLE STRIPPING DIM'S

RECOMMENDED
MOUNTING HOLE

- NOTES:
 1. CRIMPED FERRULE
 HEX CRIMP SIZE .178"
 2. CRIMPED CONTACT PIN,
 HEX CRIMP SIZE .068"

QTY	DESCRIPTION	MATERIAL	FINISH
1	HOUSING	BRASS	NICKEL
2	BODY	BRASS	NICKEL
3	INSULATOR	PTFE	NATURAL
4	INSULATOR	DELTRIN	NATURAL
5	BARREL	BRASS	NICKEL
6	LOCK WASHER	BRASS	NICKEL
7	HEX NUT	BRASS	NICKEL
8	CONTACT PIN	PHOSPHOR BRONZE	GOLD
9	SLEEVE	DELTRIN	NATURAL
10	FERRULE	COPPER	NICKEL

UNLESS OTHERWISE SPECIFIED DIMENSIONS ARE IN MILLIMETERS. DIMENSIONS IN [] ARE IN INCHES AND FOR CUSTOMER REFERENCE ONLY.

UNLESS OTHERWISE SPECIFIED TOLERANCES FOR MILLIMETERS ARE:
 0.5 - 8mm ± 0.20mm
 8 - 30mm ± 0.40mm
 30 - 120mm ± 0.50mm

UNLESS OTHERWISE SPECIFIED TOLERANCES FOR INCHES ARE:
 .020 - .315 = ± 0.007"
 .315 - 1.180 = ± 0.015"
 1.180 - 4.724 = ± 0.020"

APPROVALS	DATE
DRAWN TANGOR	02/10/10
CHECKED	
ISSUED	
SHEET 1 OF 1	
CAD FILE	C:/CONNEX/112252.DWG

Amphenol Connex

PART DESCRIPTION
**BNC BULKHEAD ISOLATED CRIMP JACK
 (FOR RG-174/U,188A/U,316/U)**

PART NO.
112252

DWG. NO.	112252.DWG	REV.	A	SIZE	A	SCALE	NA
----------	------------	------	---	------	---	-------	----

DO NOT SCALE DRAWING