

MAX680/MAX681

General Description

The MAX680/MAX681 are monolithic, CMOS, dual charge-pump voltage converters that provide $\pm 10V$ outputs from a +5V input voltage. The MAX680/MAX681 provide both a positive step-up charge pump to develop +10V from +5V input and an inverting charge pump to generate the -10V output. Both parts have an on-chip, 8kHz oscillator. The MAX681 has the capacitors internal to the package, and the MAX680 requires four external capacitors to produce both positive and negative voltages from a single supply.

The output source impedances are typically 150 Ω , providing useful output currents up to 10mA. The low quiescent current and high efficiency make this device suitable for a variety of applications that need both positive and negative voltages generated from a single supply.

The MAX864/MAX865 are also recommended for new designs. The MAX864 operates at up to 200kHz and uses smaller capacitors. The MAX865 comes in the smaller μ MAX package.

Applications

The MAX680/MAX681 can be used wherever a single positive supply is available and where positive and negative voltages are required. Common applications include generating $\pm 6V$ from a 3V battery and generating $\pm 10V$ from the standard +5V logic supply (for use with analog circuitry). Typical applications include:

- $\pm 6V$ from 3V Lithium Cell
- Hand-Held Instruments
- Data-Acquisition Systems
- Panel Meters
- $\pm 10V$ from +5V Logic Supply
- Battery-Operated Equipment
- Operational Amplifier Power Supplies

Pin Configurations

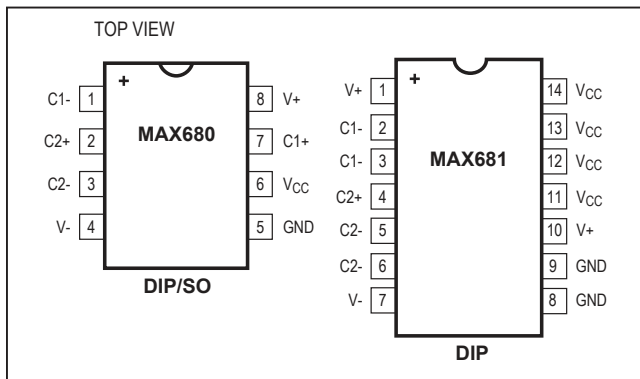

+5V to $\pm 10V$ Voltage Converters

Features

- 95% Voltage-Conversion Efficiency
- 85% Power-Conversion Efficiency
- +2V to +6V Voltage Range
- Only Four External Capacitors Required (MAX680)
- No Capacitors Required (MAX681)
- 500 μ A Supply Current
- Monolithic CMOS Design

Ordering Information

PART	TEMP. RANGE	PIN-PACKAGE
MAX680CPA	0°C to +70°C	8 Plastic DIP
MAX680CSA	0°C to +70°C	8 Narrow SO
MAX680C/D	0°C to +70°C	Dice
MAX680EPA	-40°C to +85°C	8 Plastic DIP
MAX680ESA	-40°C to +85°C	8 Narrow SO
MAX680MJA	-55°C to +125°C	8 CERDIP
MAX681CPD	0°C to +70°C	14 Plastic DIP
MAX681EPD	-40°C to +85°C	14 Plastic DIP

Typical Operating Circuits

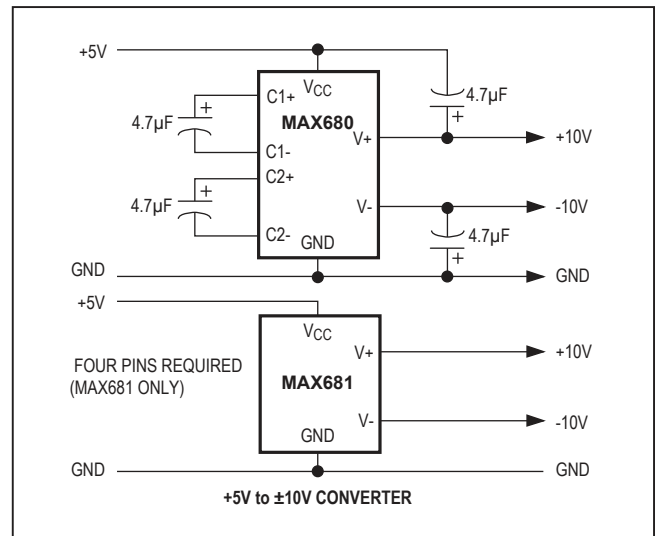

Absolute Maximum Ratings

V _{CC}	+6.2V	Continuous Power Dissipation (T _A = +70°C)
V ₊	+12V	8-Pin Plastic DIP (derate 9.09mW/°C above +70°C).....
V ₋	-12V	8-Pin Narrow SO (derate 5.88mW/°C above +70°C)....
V- Short-Circuit Duration	Continuous	8-Pin CERDIP (derate 8.00mW/°C above +70°C)
V ₊ Current	75mA	14-Pin Plastic DIP (derate 10.00mW/°C above +70°C) 800mW
V _{CC} ΔV/ΔT	1V/μs	Storage Temperature Range
		Lead Temperature (soldering, 10sec)

Stresses beyond those listed under "Absolute Maximum Ratings" may cause permanent damage to the device. These are stress ratings only, and functional operation of the device at these or any other conditions beyond those indicated in the operational sections of the specifications is not implied. Exposure to absolute maximum rating conditions for extended periods may affect device reliability.

Electrical Characteristics

(V_{CC} = +5V, test circuit Figure 1, T_A = +25°C, unless otherwise noted.)

PARAMETER	CONDITIONS	MIN	TYP	MAX	UNITS	
Supply Current	V _{CC} = 3V, T _A = +25°C, R _L = ∞		0.5	1	mA	
	V _{CC} = 5V, T _A = +25°C, R _L = ∞		1	2		
	V _{CC} = 5V, 0°C ≤ T _A ≤ +70°C, R _L = ∞			2.5		
	V _{CC} = 5V, -40°C ≤ T _A ≤ +85°C, R _L = ∞			3		
	V _{CC} = 5V, -55°C ≤ T _A ≤ +125°C, R _L = ∞			3		
Supply-Voltage Range	MIN ≤ T _A ≤ MAX, R _L = 10kΩ	2.0	1.5 to 6.0	6.0	V	
Positive Charge-Pump Output Source Resistance	I _{L+} = 10mA, I _{L-} = 0mA, V _{CC} = 5V, T _A = +25°C		150	250	Ω	
	I _{L+} = 5mA, I _{L-} = 0mA, V _{CC} = 2.8V, T _A = +25°C		180	300		
	I _{L+} = 10mA, I _{L-} = 0mA, V _{CC} = 5V	0°C ≤ T _A ≤ +70°C				325
		-40°C ≤ T _A ≤ +85°C				350
-55°C ≤ T _A ≤ +125°C				400		
Negative Charge-Pump Output Source Resistance	I _{L-} = 10mA, I _{L+} = 0mA, V ₊ = 10V, T _A = +25°C		90	150	Ω	
	I _{L-} = 5mA, I _{L+} = 0mA, V ₊ = 5.6V, T _A = +25°C		110	175		
	I _{L-} = 10mA, I _{L+} = 0mA, V _{CC} = 10V	0°C ≤ T _A ≤ +70°C				200
		-40°C ≤ T _A ≤ +85°C				200
-55°C ≤ T _A ≤ +125°C				250		
Oscillator Frequency		4	8		kHz	
Power Efficiency	R _L = 10kΩ		85		%	
Voltage-Conversion Efficiency	V ₊ , R _L = ∞	95	99		%	
	V ₊ , R _L = ∞	90	97			

Typical Operating Characteristics

($T_A = +25^\circ\text{C}$, unless otherwise noted.)

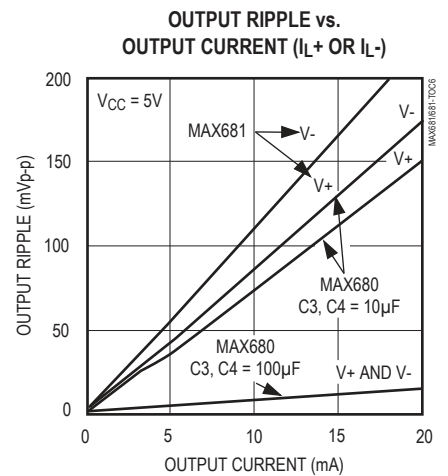
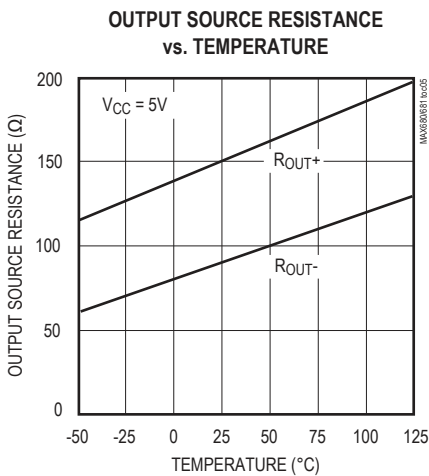
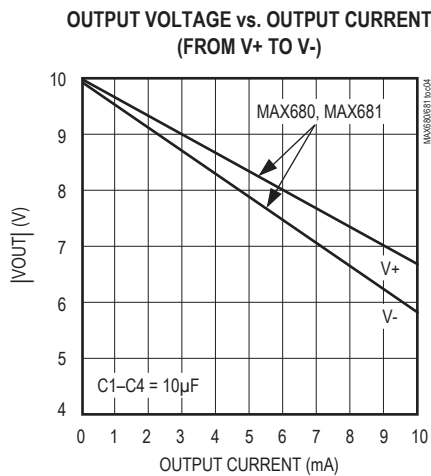
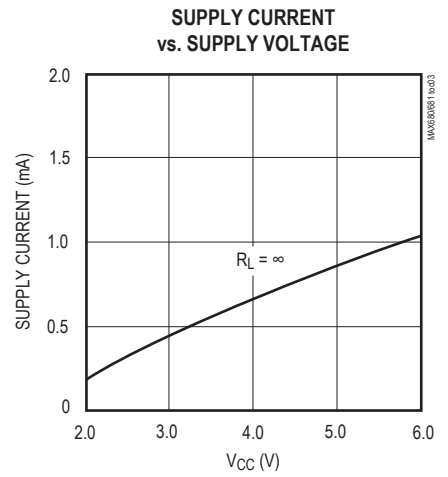
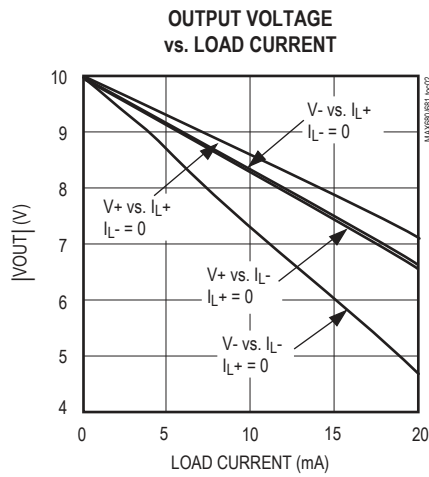
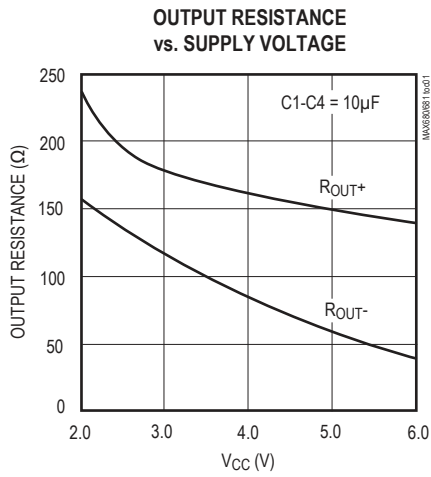

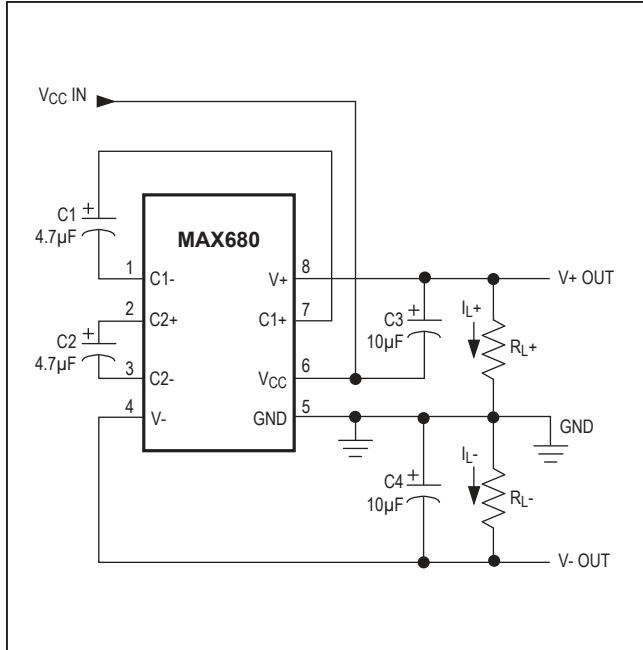

Figure 1. Test Circuit

Detailed Description

The MAX681 contains all circuitry needed to implement a dual charge pump. The MAX680 needs only four capacitors. These may be inexpensive electrolytic capacitors with values in the 1µF to 100µF range. The MAX681 contains two 1.5µF capacitors as C1 and C2, and two 2.2µF capacitors as C3 and C4. See *Typical Operating Characteristics*.

Figure 2a shows the idealized operation of the positive voltage converter. The on-chip oscillator generates a 50% duty-cycle clock signal. During the first half of the cycle, switches S2 and S4 are open, S1 and S3 are closed, and capacitor C1 is charged to the input voltage V_{CC} . During the second half-cycle, S1 and S3 are open, S2 and S4 are closed, and C1 is translated upward by V_{CC} volts. Assuming ideal switches and no load on C3, charge is transferred onto C3 from C1 such that the voltage on C3 will be $2V_{CC}$, generating the positive supply.

Figure 2b shows the negative converter. The switches of the negative converter are out of phase from the positive converter. During the second half of the clock cycle, S6 and S8 are open and S5 and S7 are closed, charging C2 from $V+$ (pumped up to $2V_{CC}$ by the positive charge pump) to GND. In the first half of the clock

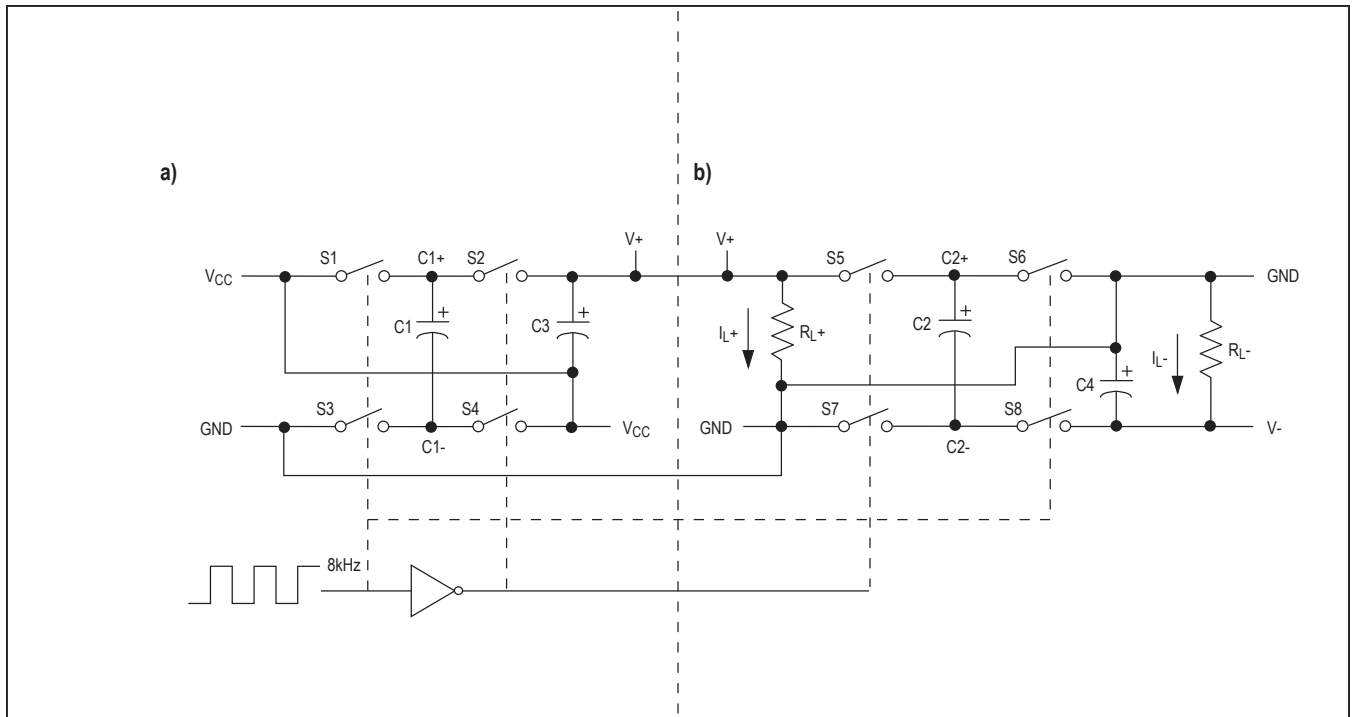

Figure 2. Idealized Voltage Quadrupler: a) Positive Charge Pump; b) Negative Charge Pump

cycle, S5 and S7 are open, S6 and S8 are closed, and the charge on C2 is transferred to C4, generating the negative supply. The eight switches are CMOS power MOSFETs. S1, S2, S4, and S5 are P-channel switches, while S3, S6, S7, and S8 are N-channel switches.

Efficiency Considerations

Theoretically, a charge-pump voltage multiplier can approach 100% efficiency under the following conditions:

- The charge-pump switches have virtually no offset and extremely low on-resistance
- Minimal power is consumed by the drive circuitry
- The impedances of the reservoir and pump capacitors are negligible

For the MAX680/MAX681, the energy loss per clock cycle is the sum of the energy loss in the positive and negative converters as below:

$$\begin{aligned} \text{LOSS}_{\text{TOT}} &= \text{LOSS}_{\text{POS}} + \text{LOSS}_{\text{NEG}} \\ &= \frac{1}{2} C1 [(V+)^2 - (V+)(V_{\text{CC}})] + \\ &\quad \frac{1}{2} C2 [(V+)^2 - (V-)^2] \end{aligned}$$

There will be a substantial voltage difference between $(V+ - V_{\text{CC}})$ and V_{CC} for the positive pump, and between $V+$ and $V-$, if the impedances of pump capacitors C1 and C2 are high relative to their respective output loads.

Larger C3 and C4 reservoir capacitor values reduce output ripple. Larger values of both pump and reservoir capacitors improve efficiency.

Maximum Operating Limits

The MAX680/MAX681 have on-chip zener diodes that clamp V_{CC} to approximately 6.2V, $V+$ to 12.4V, and $V-$ to -12.4V. Never exceed the maximum supply voltage: excessive current may be shunted by these diodes, potentially damaging the chip. The MAX680/MAX681 operate over the entire operating temperature range with an input voltage of +2V to +6V.

Applications

Positive and Negative Converter

The most common application of the MAX680/MAX681 is as a dual charge-pump voltage converter that provides positive and negative outputs of two times a positive input voltage. For applications where PC board space is at a premium, the MAX681, with its capacitors internal to the package, offers the smallest footprint. The simple circuit shown in Figure 3 performs the same function using the MAX680 with external capacitors C1 and C3 for the positive pump and C2 and C4 for the negative pump. In most applications, all four capacitors are low-cost, 10µF or 22µF polarized electrolytics. When using the MAX680 for low-current applications, 1µF can be used for C1 and C2 charge-pump capacitors, and 4.7µF for C3 and C4 reservoir capacitors. C1 and C3 must be rated at 6V or greater, and C2 and C4 must be rated at 12V or greater.

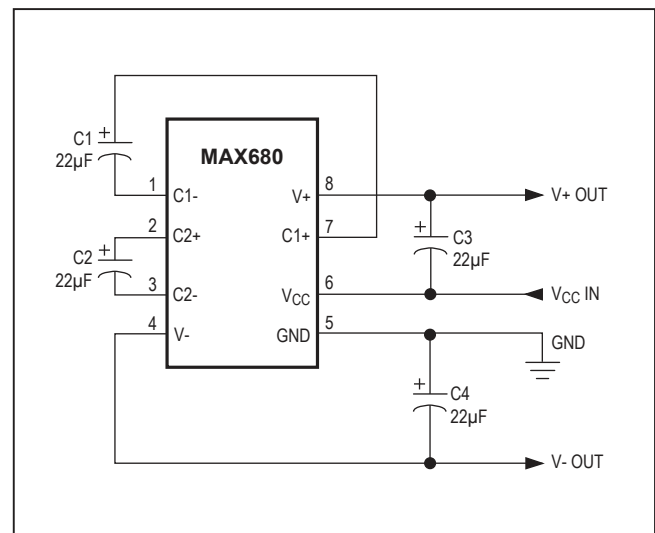

Figure 3. Positive and Negative Converter

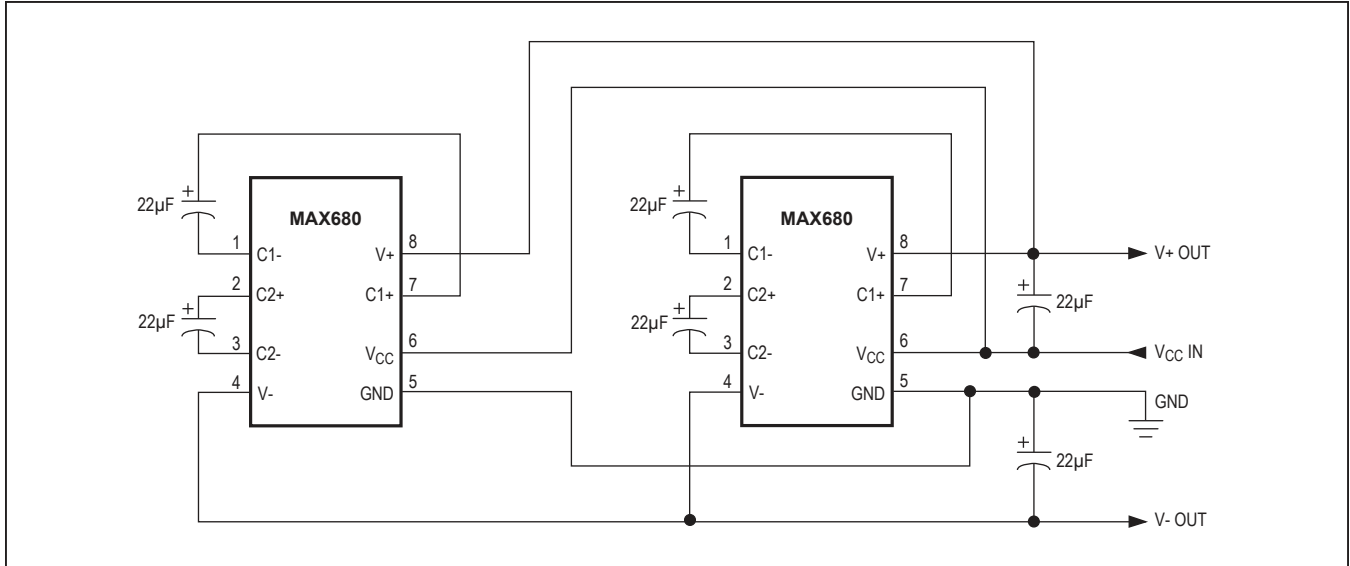

Figure 4. Paralleling MAX680s For Lower Source Resistance

The MAX680/MAX681 are **not** voltage regulators: the output source resistance of either charge pump is approximately 150Ω at room temperature with V_{CC} at 5V. Under light load with an input V_{CC} of 5V, V₊ will approach +10V and V₋ will be at -10V. However **both**, V₊ and V₋ will droop toward GND as the current drawn from **either** V₊ or V₋ increases, since the negative converter draws its power from the positive converter's output. To predict output voltages, treat the chips as two separate converters and analyze them separately. First, the droop of the negative supply (V_{DROP-}) equals the current drawn from V₋ (I_{L-}) times the source resistance of the negative converter (RS₋):

$$V_{DROPP-} = I_{L-} \times RS_{-}$$

Likewise, the positive supply droop (V_{DROP+}) equals the current drawn from the positive supply (I_{L+}) times the positive converter's source resistance (RS₊), except that the current drawn from the positive supply is the sum of the current drawn by the load on the positive supply (I_{L+}) plus the current drawn by the negative converter (I_{L-}):

$$(V_{DROPP+}) = I_{L+} \times RS_{+} = (I_{L+} + I_{L-}) \times RS_{+}$$

The positive output voltage will be:

$$V_{+} = 2V_{CC} - V_{DROPP+}$$

The negative output voltage will be:

$$V_{-} = (V_{+} - V_{DROPP-}) = -(2V_{CC} - V_{DROPP+} - V_{DROPP-})$$

The positive and negative charge pumps are tested and specified separately to provide the separate values of output source resistance for use in the above formulas. When the positive charge pump is tested, the negative charge pump is unloaded. When the negative charge pump is tested, the positive supply V₊ is from an external source, isolating the negative charge pump.

Calculate the ripple voltage on either output by noting that the current drawn from the output is supplied by the reservoir capacitor alone during one half-cycle of the clock. This results in a ripple of:

$$V_{RIPPLE} = \frac{1}{2} I_{OUT} (1/f_{PUMP})(1/CR)$$

For the nominal f_{PUMP} of 8kHz with 10µF reservoir capacitors, the ripple will be 30mV with I_{OUT} at 5mA. Remember that in most applications, the positive charge pump's I_{OUT} is the load current **plus** the current taken by the negative charge pump.

Paralleling Devices

Paralleling multiple MAX680/MAX681s reduces the output resistance of both the positive and negative converters. The effective output resistance is the output resistance of a single device divided by the number of devices. As Figure 4 shows, each MAX680 requires separate pump capacitors C1 and C2, but all can share a single set of reservoir capacitors.

±5V Regulated Supplies from a Single 3V Battery

Figure 5 shows a complete ±5V power supply using one 3V battery. The MAX680/MAX681 provide +6V at V+, which is regulated to +5V by the MAX666, and -6V, which is regulated to -5V by the MAX664. The MAX666 and MAX664 are pretrimmed at wafer sort and require

no external setting resistors, minimizing part count. The combined quiescent current of the MAX680/MAX681, MAX663, and MAX664 is less than 500µA, while the output current capability is 5mA. The MAX680/MAX681 input can vary from 3V to 6V without affecting regulation appreciably. With higher input voltage, more current can be drawn from the MAX680/MAX681 outputs. With 5V at V_{CC}, 10mA can be drawn from both regulated outputs simultaneously. Assuming 150Ω source resistance for both converters, with (I_{L+} + I_{L-}) = 20mA, the positive charge pump will droop 3V, providing +7V for the negative charge pump. The negative charge pump will droop another 1.5V due to its 10mA load, leaving -5.5V at V₋ sufficient to maintain regulation for the MAX664 at this current.

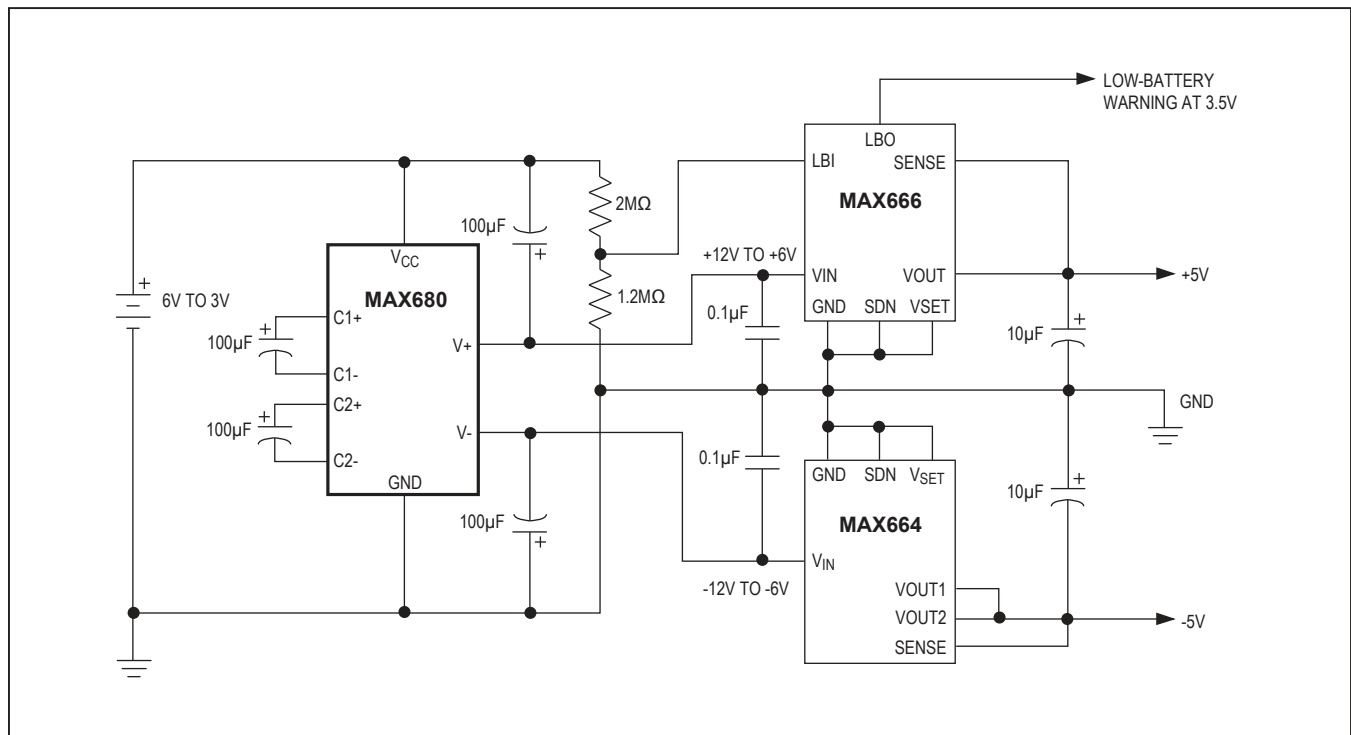
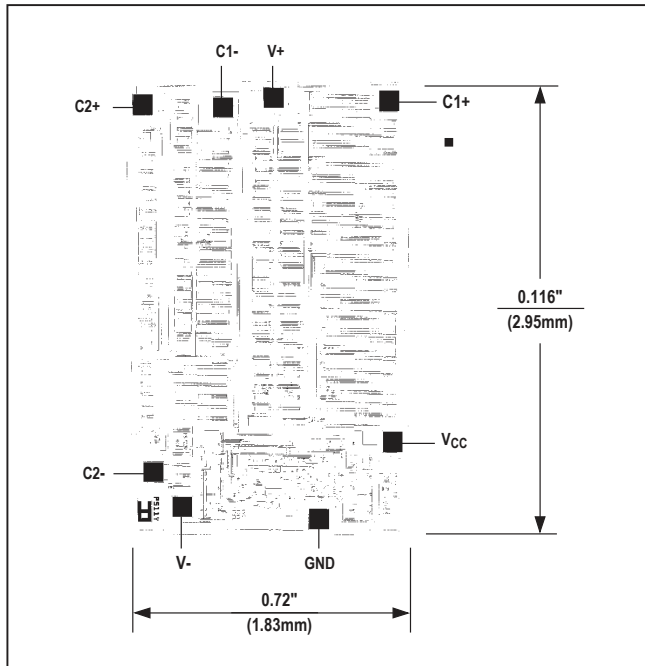

Figure 5. Regulated +5V and -5V from a Single Battery

Chip Topography



Package Information

For the latest package outline information and land patterns (footprints), go to www.maximintegrated.com/packages. Note that a "+", "#", or "-" in the package code indicates RoHS status only. Package drawings may show a different suffix character, but the drawing pertains to the package regardless of RoHS status.

TOP VIEW

END VIEW

SIDE VIEW

COMMON DIMENSIONS

SYMBOL	INCHES		MM	
	MIN.	MAX.	MIN.	MAX.
A	.053	.069	1.35	1.75
A1	.004	.010	0.10	0.25
b	.014	.019	0.35	0.49
c	.007	.010	0.19	0.25
E	.150	.157	3.80	4.00
e	.050 BSC		1.27 BSC	
H	.228	.244	5.80	6.20
L	.016	.050	0.40	1.27
α	0°	8°	0°	8°

VARIATION A

SYMBOL	INCHES		MM	
	MIN.	MAX.	MIN.	MAX.
D	.189	.197	4.80	5.00
N	8			
MS012	AA			
PKG. CODE	S8-2, S8-4, S8-5, S8-6F, S8-7F, S8-8F, S8-10F, S8-11F, S8-16F			

VARIATION B

SYMBOL	INCHES		MM	
	MIN.	MAX.	MIN.	MAX.
D	.337	.344	8.55	8.75
N	14			
MS012	AB			
PKG. CODE	S14-1, S14-4, S14-5, S14-6, S14M-4, S14M-5, S14M-6, S14M-7			

VARIATION C

SYMBOL	INCHES		MM	
	MIN.	MAX.	MIN.	MAX.
D	.386	.394	9.80	10.00
N	16			
MS012	AC			
PKG. CODE	S16-1, S16-3, S16-5, S16-6, S16-8, S16-7F, S16-9F, S16-10F, S16M-3, S16M-6			

NOTES:

- ALL DIMENSIONS ARE IN MILLIMETERS UNLESS OTHERWISE SPECIFIED.
- MATERIAL MUST COMPLY WITH BANNED AND RESTRICTED SUBSTANCES SPEC # 10-0131.
- DIMENSIONS D AND E DO NOT INCLUDE MOLD PROTRUSION. ALLOWABLE MOLD PROTRUSION IS 0.15 MM (.006") PER SIDE.
- LEADS TO BE COPLANAR WITHIN 0.10mm (.004").
- MEETS JEDEC MS012
- ALL DIMENSIONS APPLY TO BOTH LEADED (-) AND PbFREE (+) PKG. CODES.

-DRAWING NOT TO SCALE-

maxim integrated.

TITLE:
PACKAGE OUTLINE,
8L, 14L, 16L SOIC .150 INCH

APPROVAL	DOCUMENT CONTROL NO. 21-0041	REV. C	1/1
----------	---------------------------------	-----------	-----

For pricing, delivery, and ordering information, please visit Maxim Integrated's online storefront at <https://www.maximintegrated.com/en/storefront/storefront.html>.

Maxim Integrated cannot assume responsibility for use of any circuitry other than circuitry entirely embodied in a Maxim Integrated product. No circuit patent licenses are implied. Maxim Integrated reserves the right to change the circuitry and specifications without notice at any time. The parametric values (min and max limits) shown in the Electrical Characteristics table are guaranteed. Other parametric values quoted in this data sheet are provided for guidance.