

- 1 HOUSING MATERIAL: GLASS-FILLED POLYMER.
- 2 POST MATERIAL: COPPER ALLOY.
- 3 POST FINISH: DIN 41612 CLASS 2 IN CONTACT AREA. TIN PLATE ON POSTS.
- 4 FOR 1.57[.062] THICK PC BOARD APPLICATIONS, USE SEATING TOOL 768211-4. PROGRAMMABLE SEATING TOOL 768216-4 WITH PUSH PINS FOR MAKE FIRST CONTACTS ONLY, CAN ALSO BE USED.
- 5 PC BOARD HOLES REQUIRED FOR ACTION PIN CONTACTS ARE 1.151[.0453] DRILL DIAMETER PLATED THROUGH WITH 0.02-.08[.001-.003] COPPER AND 0.008[.0003] MINIMUM TIN-LEAD PLATING. FINISHED HOLE AFTER PLATING, 0.94-1.09[.037-.043] DIAMETER.
- 6 PART NUMBER, DATE CODE MARKED THIS APPROXIMATE AREA.
- 7 MARKING ON THIS SIDE.
- 8 FOR "MFBL" APPLICATIONS, A 2.36[.093] MINIMUM THICK PC BOARD IS REQUIRED. PROGRAMMABLE SEATING TOOL 768216-4 MUST BE USED.
- 9 TO BE 4.16[.164] REF FOR LAST MAKE PINS AFTER SEATING. POST LENGTH DIFFERENCE BETWEEN SHORT AND LONG PINS TO BE 0.76±0.2[.030±.008] AFTER SEATING.
- 10 THIS DIMENSION WILL BE 6.35±0.51[.250±.020] AFTER SEATING FOR PINS WITH 4.17[.164] REF MATING POST.

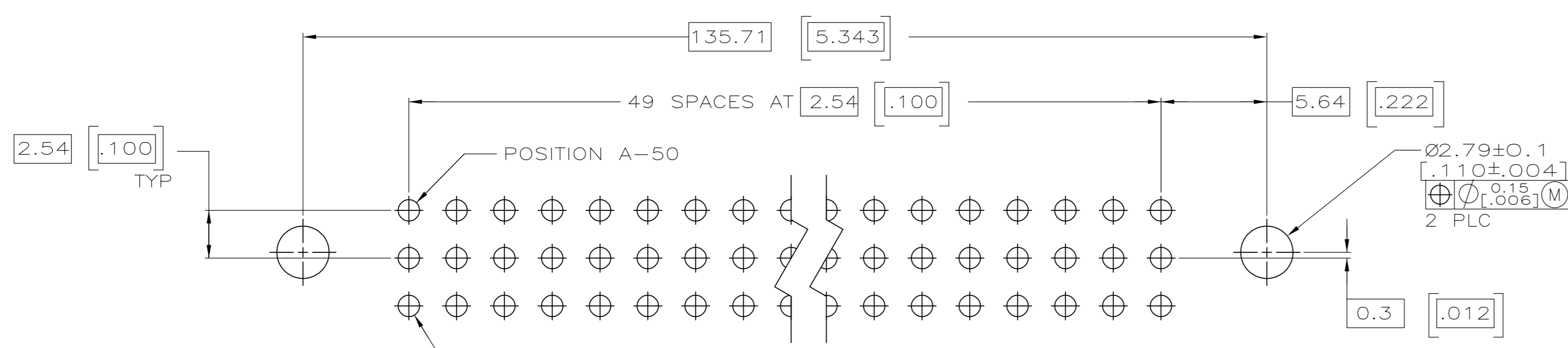
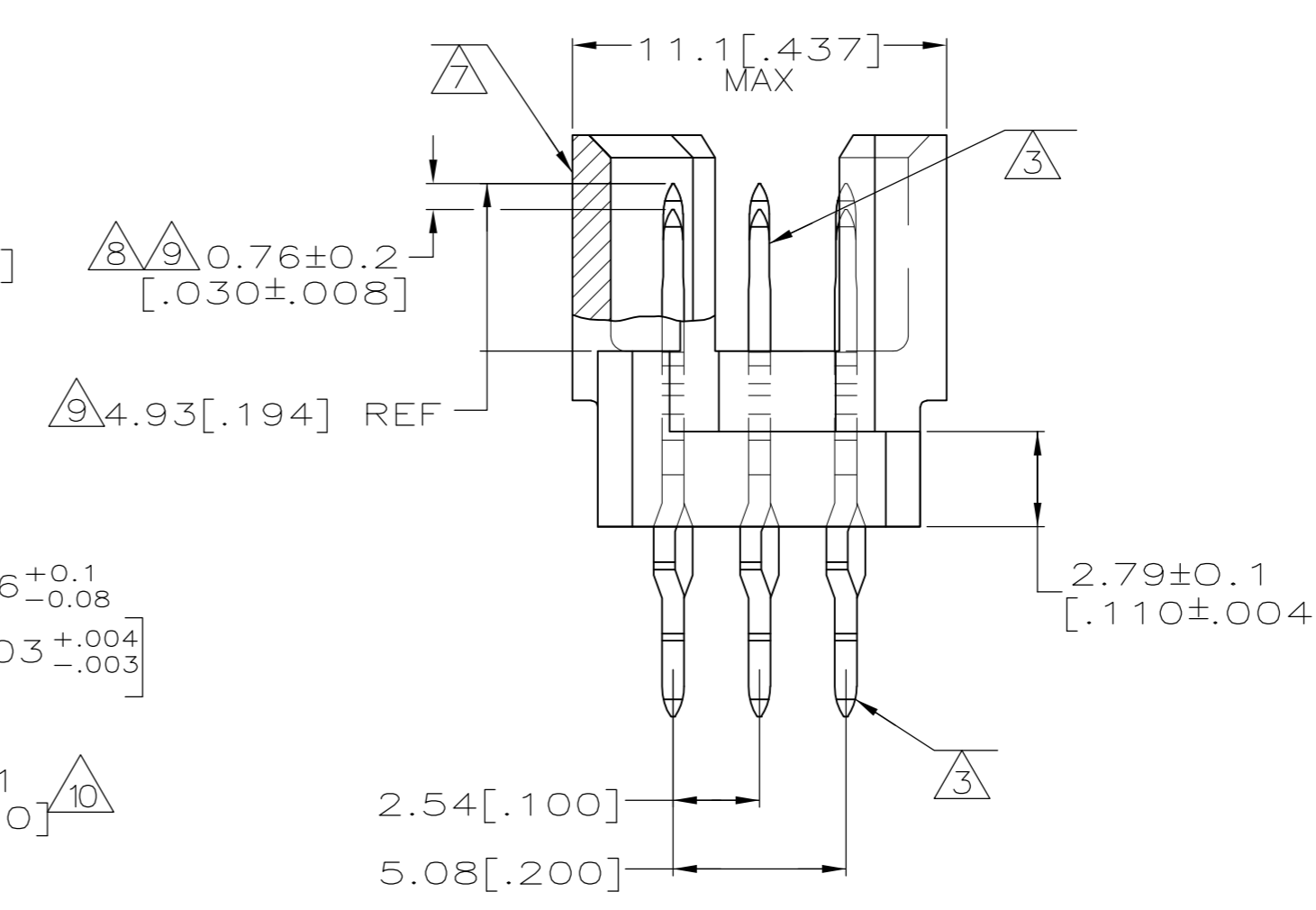

PC BOARD LAYOUT

1-50	X	X	X	150	5536096-5
POSITIONS LOADED	C	B	A	NO. OF LOADED POSITIONS	ASSY PART NUMBER
	ROWS LOADED				

THIS DRAWING IS A CONTROLLED DOCUMENT.		DWN J. POLIGNONE		Tyco Electronics Corporation Harrisburg, Pa 17105-3608	
DIMENSIONS: mm [INCHES]		CHK A. SHARPE		NAME	
TOLERANCES UNLESS OTHERWISE SPECIFIED:		APPD A. SHARPE		ASSEMBLY, PIN, EUROCARD, TYPE R, 150 POSITION, 6.35[.250] PRESS FIT POSTS, PROGRAMMABLE	
0 PLC ± -		PRODUCT SPEC		APPLICATION SPEC	
1 PLC ± -		SIZE		CAGE CODE	
2 PLC ± -		WEIGHT		DRAWING NO	
3 PLC ± 0.1[.005]		A1		00779	
4 PLC ± -		CUSTOMER DRAWING		SCALE 5:1	
ANGLES ± -		SHEET 1 OF 1		REV 01	