

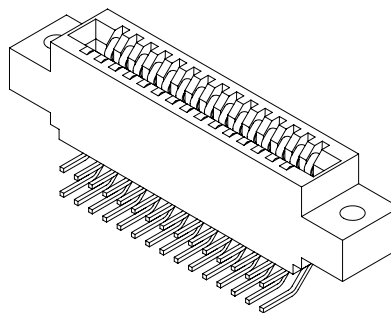

**.100" [2.54 mm] Contact Centers, .560" [14.22 mm] Profile, .400" [10.16 mm] Wide Body, Double Point Contact, Dip Solder/Wire Wrap/Right Angle/Card Extender**

**SPECIFICATIONS**

- Accommodates .062" ± .008" [1.57 mm ± 0.20 mm] PC board
- PPS, PBT or PA9T insulator
- 3 Amps current rating for one contact energized
- 30 milli Ohms maximum at rated current
- UL Flammability Rating: 94V-0



**TERMINATION TYPE**

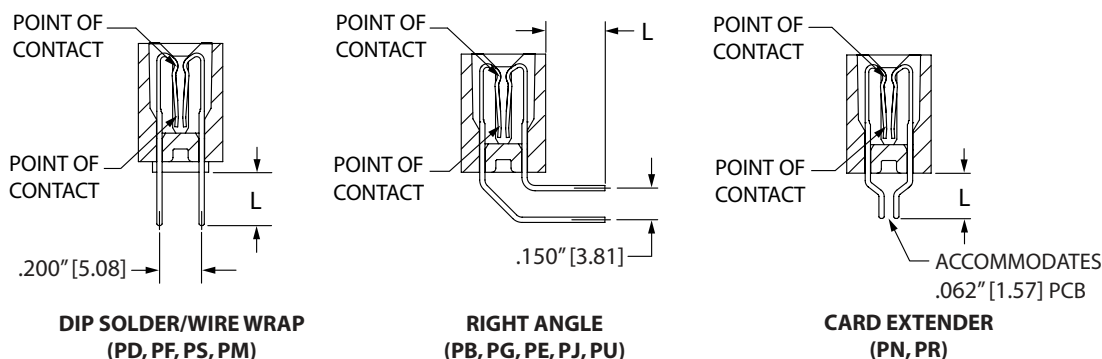

TERMINATION	TERMINATION TYPE	* POST LENGTH L ±.025" [0.64]	FITS MIN. HOLE SIZE	STANDOFF
PD	DIP SOLDER	.160" [4.06]	.043" [1.09]	YES
PS	DIP SOLDER	.190" [4.83]	.043" [1.09]	YES
PF	DIP SOLDER	.270" [6.86]	.043" [1.09]	YES
PM	WIRE WRAP	.560" [14.22]	.043" [1.09]	YES
PB	RIGHT ANGLE	.100" [2.54]	.043" [1.09]	NO
PG	RIGHT ANGLE	.140" [3.56]	.043" [1.09]	NO
PE	RIGHT ANGLE	.180" [4.57]	.043" [1.09]	NO
PU	RIGHT ANGLE	.250" [6.35]	.043" [1.09]	NO
PJ	RIGHT ANGLE	.500" [12.70]	.043" [1.09]	NO
PR	CARD EXTENDER	.225" [5.73]	N/A	NO
PN	CARD EXTENDER	.595" [15.12]	N/A	NO

\* OTHER POST LENGTHS AVAILABLE, CONTACT FACTORY.

**MOUNTING STYLE** (Standoffs included on straight terminations only.)

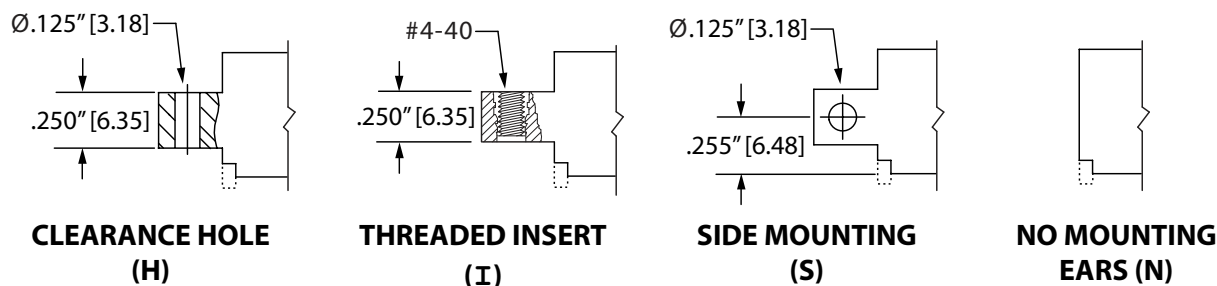



**.100" [2.54 mm] Contact Centers, .560" [14.22 mm] Profile, .400" [10.16 mm] Wide Body, Double Point Contact, Dip Solder/Wire Wrap/Right Angle/Card Extender**

### PART NUMBER OPTIONS

#### MATERIALS (INSULATOR/CONTACT)

- E = PBT/Phosphor Bronze
- R = PPS/Phosphor Bronze
- G = PA9T/Phosphor Bronze
- H = PBT/Beryllium Copper
- A = PPS/Beryllium Copper
- J = PA9T/Beryllium Copper

(Consult factory for other materials.)

Refer to Page 7 for Operating/Processing Temperatures

#### CONTACT FINISH - RoHS Compliant

All platings are Lead Free and have .000050" Nickel underplate

- | Contact Surface   | Termination              |
|-------------------|--------------------------|
| B = .000010" Gold | .000100" Pure Tin, Matte |
| C = .000030" Gold | .000100" Pure Tin, Matte |

#### CONTACT CENTERS

- C = .100" [2.54 mm]

#### NUMBER OF CONTACT POSITIONS

See Chart Below

**E B C 10 D PD H - Sxxx**

**MODIFICATION CODE** (Consult Factory)  
OMIT FOR STANDARD

#### MOUNTING STYLE (Opposite Page)

- H = Clearance Holes
- I = Threaded Inserts
- S = Side Mounting
- N = No Mounting

#### TERMINATION TYPE (Opposite Page)

- PD, PF, PS = .025" [0.64 mm] Square Dip Solder
- PM = .025" [0.64 mm] Square Wire Wrap
- PB, PG, PE, PJ, PU = .025" [0.64 mm] Square Right Angle
- PN, PR = .025" [0.64 mm] Square Card Extender

#### READOUT (Opposite Page)

- D = Dual

### DIMENSIONS Dimensions in [ ] are in millimeters, all others are in inches.

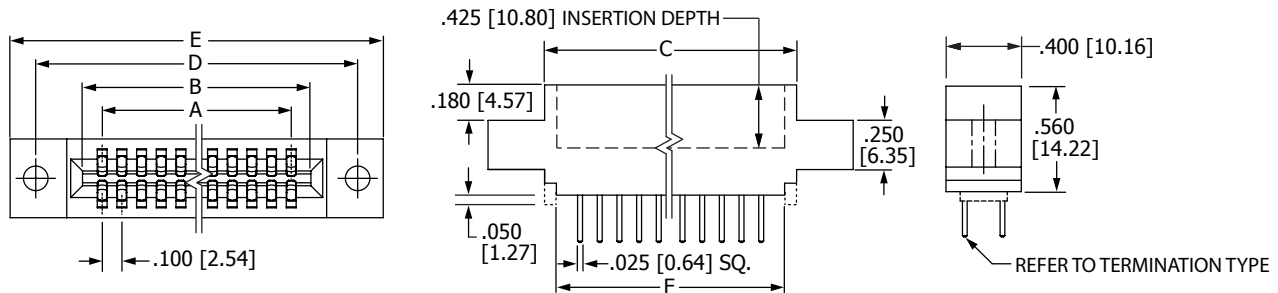

Tolerances on non-critical dimensions may vary slightly due to shrinkage differential per insulator material; Consult factory.

POSITIONS/ CONTACTS	INCHES						MILLIMETERS					
	A±.008	B±.008	C±.015	D±.010	E±.020	F±.015	A±0.20	B±0.20	C±0.38	D±0.25	E±0.51	F±0.38
06/12	0.500	0.700	0.860	1.175	1.435	0.740	12.70	17.78	21.84	29.85	36.45	18.80
07/14*	0.600	0.800	0.960	1.275	1.535	0.840	15.24	20.32	24.38	32.39	38.99	21.34
08/16	0.700	0.900	1.060	1.375	1.635	0.940	17.78	22.86	26.92	34.93	41.53	23.88
10/20	0.900	1.100	1.260	1.575	1.835	1.140	22.86	27.94	32.00	40.01	46.61	28.96
12/24*	1.100	1.300	1.460	1.775	2.035	1.340	27.94	33.02	37.08	45.09	51.69	34.04
13/26*	1.200	1.400	1.560	1.875	2.135	1.440	30.48	35.56	39.62	47.63	54.23	36.58
15/30	1.400	1.600	1.760	2.075	2.335	1.640	35.56	40.64	44.70	52.71	59.31	41.66
17/34*	1.600	1.800	1.960	2.275	2.535	1.840	40.64	45.72	49.78	57.79	64.39	46.74
18/36*	1.700	1.900	2.060	2.375	2.635	1.940	43.18	48.26	52.32	60.33	66.93	49.28
20/40	1.900	2.100	2.260	2.575	2.835	2.140	48.26	53.34	57.40	65.41	72.01	54.36
22/44*	2.100	2.300	2.460	2.775	3.035	2.340	53.34	58.42	62.48	70.49	77.09	59.44
24/48*	2.300	2.500	2.660	2.975	3.235	2.540	58.42	63.50	67.56	75.57	82.17	64.52
25/50*	2.400	2.600	2.760	3.075	3.335	2.640	60.96	66.04	70.10	78.11	84.71	67.06
28/56*	2.700	2.900	3.060	3.375	3.635	2.940	68.58	73.66	77.72	85.73	92.33	74.68
30/60	2.900	3.100	3.260	3.575	3.835	3.140	73.66	78.74	82.80	90.81	97.41	79.76
31/62*	3.000	3.200	3.360	3.675	3.935	3.240	76.20	81.28	85.34	93.35	99.95	82.30
35/70*	3.400	3.600	3.760	4.075	4.335	3.640	86.36	91.44	95.50	103.51	110.11	92.46
36/72*	3.500	3.700	3.860	4.175	4.435	3.740	88.90	93.98	98.04	106.05	112.65	95.00
40/80	3.900	4.100	4.260	4.575	4.835	4.140	99.06	104.14	108.20	116.21	122.81	105.16
43/86	4.200	4.400	4.560	4.875	5.135	4.440	106.68	111.76	115.82	123.83	130.43	112.78
44/88	4.300	4.500	4.660	4.975	5.235	4.540	109.22	114.30	118.36	126.37	132.97	115.32
49/98*	4.800	5.000	5.160	5.475	5.735	5.040	121.92	127.00	131.06	139.07	145.67	128.02
50/100	4.900	5.100	5.260	5.575	5.835	5.140	124.46	129.54	133.60	141.61	148.21	130.56
55/110*	5.400	5.600	5.760	6.075	6.335	5.640	137.16	142.24	146.30	154.31	160.91	143.26
60/120*	5.900	6.100	6.260	6.575	6.835	6.140	149.86	154.94	159.00	167.01	173.61	155.96
61/122*	6.000	6.200	6.360	6.675	6.935	6.240	152.40	157.48	161.54	169.55	176.15	158.50
65/130*	6.400	6.600	6.760	7.075	7.335	6.640	162.56	167.64	171.70	179.71	186.31	168.66
70/140*	6.900	7.100	7.260	7.575	7.835	7.140	175.26	180.34	184.40	192.41	199.01	181.36

\* Consult factory for availability.