



ON Semiconductor®

<http://onsemi.com>

STK681-360-E

Thick-Film Hybrid IC

Forward/Reverse Motor Driver

Overview

The STK681-360-E is a hybrid IC for use in PWM current control forward/reverse DC motor driver with brush.

Applications

- Office photocopiers, printers, etc.

Features

- Allows forward, reverse, and brake operations in accordance with the external input PWM signal.
- 5.8A peak startup output current and 8A peak brake output current.
- Built-in current detection resistor (0.05Ω : resistor tolerance $\pm 2\%$) and supports constant-current control.
- Obviate the need to design for the dead time in order to turn off the upper- and lower drive devices when switching between the forward and reverse operation mode.

Specifications

Absolute maximum ratings at $T_c = 25^\circ\text{C}$

Parameter	Symbol	Conditions	Ratings	unit
Maximum supply voltage 1	V _{cc1} max	V _{cc2} =0V	52	V
Maximum supply voltage 2	V _{cc2} max	No signal	-0.3 to +7.0	V
Input voltage	V _{IN} max	Logic input pins	-0.3 to +7.0	V
Output current1	I _O max	V _{DD} =5.0V, DC current	5.8	A
Brake current	I _{OB} max	V _{DD} =5.0V, square wave current, operating time 60ms (single pulse ,low side brake)	8	A
Allowable power dissipation	P _{dPK} max	No heat sink	3.1	W
Operating substrate temperature	T _c	Metal surface temperature of the package	105	°C
Junction temperature	T _j max		150	°C
Storage temperature	T _{stg}		-40 to +125	°C

Stresses exceeding Maximum Ratings may damage the device. Maximum Ratings are stress ratings only. Functional operation above the Recommended Operating Conditions is not implied. Extended exposure to stresses above the Recommended Operating Conditions may affect device reliability.

ORDERING INFORMATION

See detailed ordering and shipping information on page 12 of this data sheet.

STK681-360-E

Allowable Operating Ranges at $T_a = 25^\circ\text{C}$

Parameter	Symbol	Conditions	Ratings	unit
Operating supply voltage 1	Vcc1	With signals applied	10 to 30	V
Operating supply voltage 2	Vcc2	With signals applied	5±5%	V
Input voltage	V _{IN}	10,11,12,13,14,15,17pin	0 to Vcc2	V
Output current 1 *1,3	I _{O1}	Vcc2=5.0V, DC current, Tc ≤ 70°C	4.5	A
Output current 2 *1,3	I _{O2}	Vcc2=5.0V, DC current, Tc=90°C	3.7	A
Output current 2 *1,3	I _{O3}	Vcc2=5.0V, DC current, Tc=105°C	3.0	A
Brake current *1	I _{OB}	Vcc2=5.0V, square wave current, operating time 3.6ms, Low side brake, Tc=105°C	8.0	A
PMM pin frequency range *2	PWM	Minimum pulse width: at least 10μs	0 to 20	kHz
Recommended operating substrate temperature	Tc	No condensation	0 to 105	°C

Notes

*1 Refer to the graph for each conduction-period tolerance range for the output current and brake current.

*2 PWM pin (14pin) is active Low.

*3 Io1, Io2, Io3 connect Vref2 pin to GND and a current value when over-heating current control does not work.

Electrical Characteristics at Tc=25°C, VCC=24V, VDD=5.0V *4

Parameter	Symbol	Conditions	min	typ	max	unit
VCC2 supply current	I _{CCO}	Forward or reverse operation		2.6	3.5	mA
FET diode forward voltage	V _{df}	I _f =1A (R _L =23Ω)		0.8	1.4	V
Output saturation voltage 1	V _{sat1}	R _L =23Ω, F1, F2		0.09	0.15	V
Output saturation voltage 2	V _{sat2}	R _L =23Ω, F3, F4+ current detection resistor		0.11	0.17	V
Output leak current	I _{OL}	F1, F2, F3, and F4 OFF operation			50	μA
Input high voltage 1	V _{IH1}	IN1, IN2 pin	4.5			V
Input high voltage 2	V _{IH2}	PWM pin	4.5			V
Input low voltage	V _{IL}	IN1, IN2 and PWM pins			0.6	V
Input current	I _{IH1}	IN1, IN2 pins, V _{IH1} =5V	0.1	0.2	0.4	mA
Current setting voltage	V _{ref1}	Between V _{ref1} and S.P pins		0.29		V
PWM Input current	I _{ILP}	PWM pin, V _{IL} =GND	0.1	0.6	0.65	mA
PWM pin turn-on delay time	ton-*	Output current 1A		0.8		μs
PWM pin turn-on delay time	toff-*	Output current 1A		3.5		μs

Notes

*4: A fixed-voltage power supply must be used.

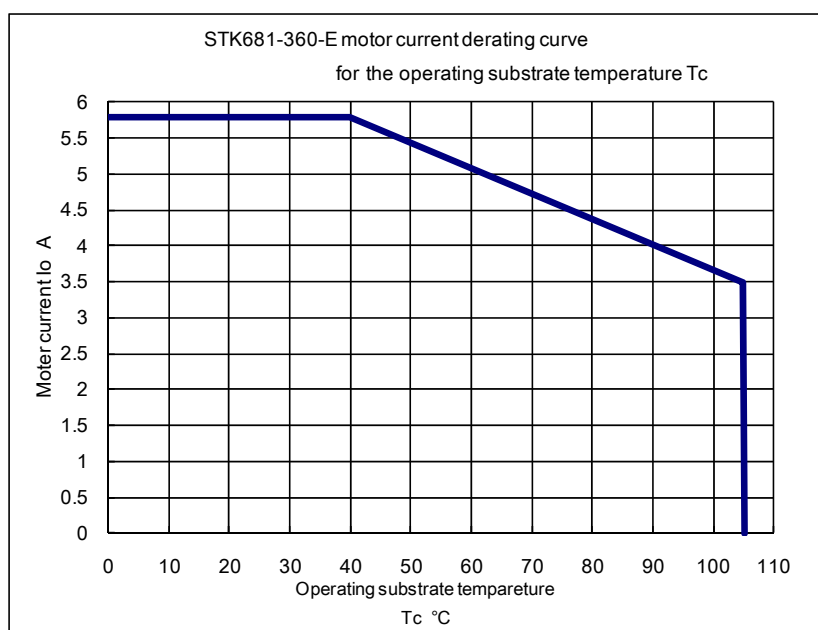

STK681-360-E

Notes

- The motor current I_o shown above is the range for DC and chopping operation.
The DC operating current range is within both the allowable V_{cc1} operating range and the derating curve shown in the figure.
- The operating substrate temperatures in the figure above are values measured when the motor is operating.
The temperature T_c varies with the ambient temperature T_a , the motor drive current, and whether the motor current is continuous or the state of its intermittent operation. Therefore T_c must be verified in an actual end product system.
- The T_c temperature should be checked in the center of the metal surface of the product package.

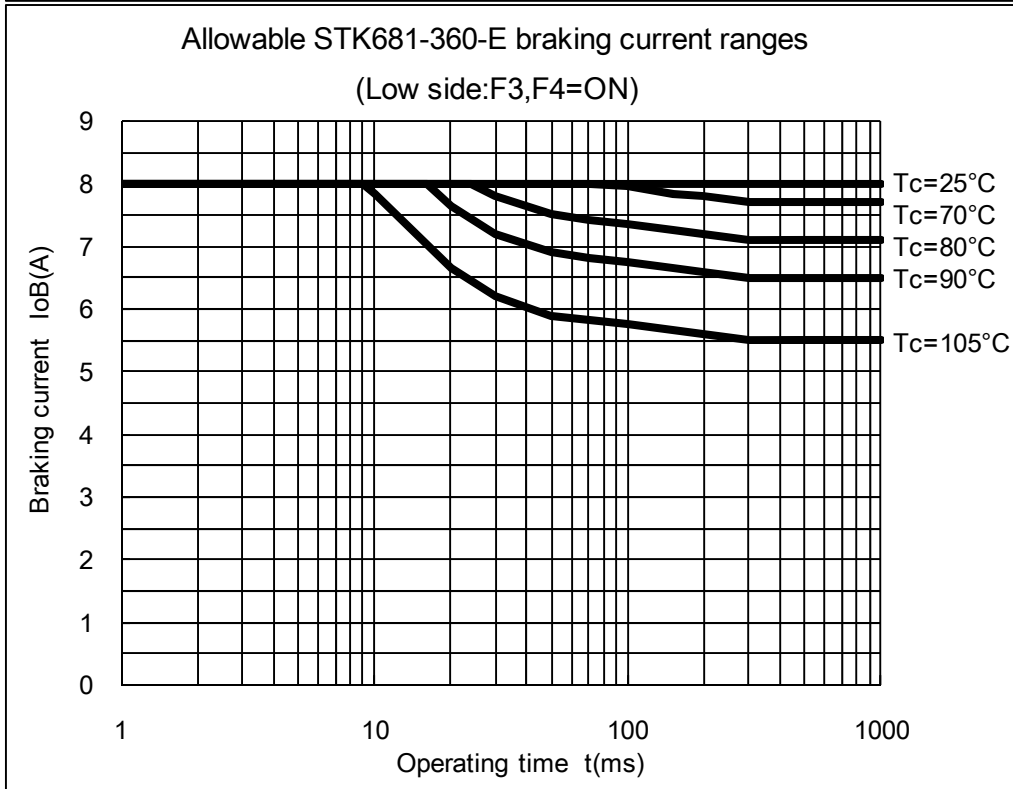
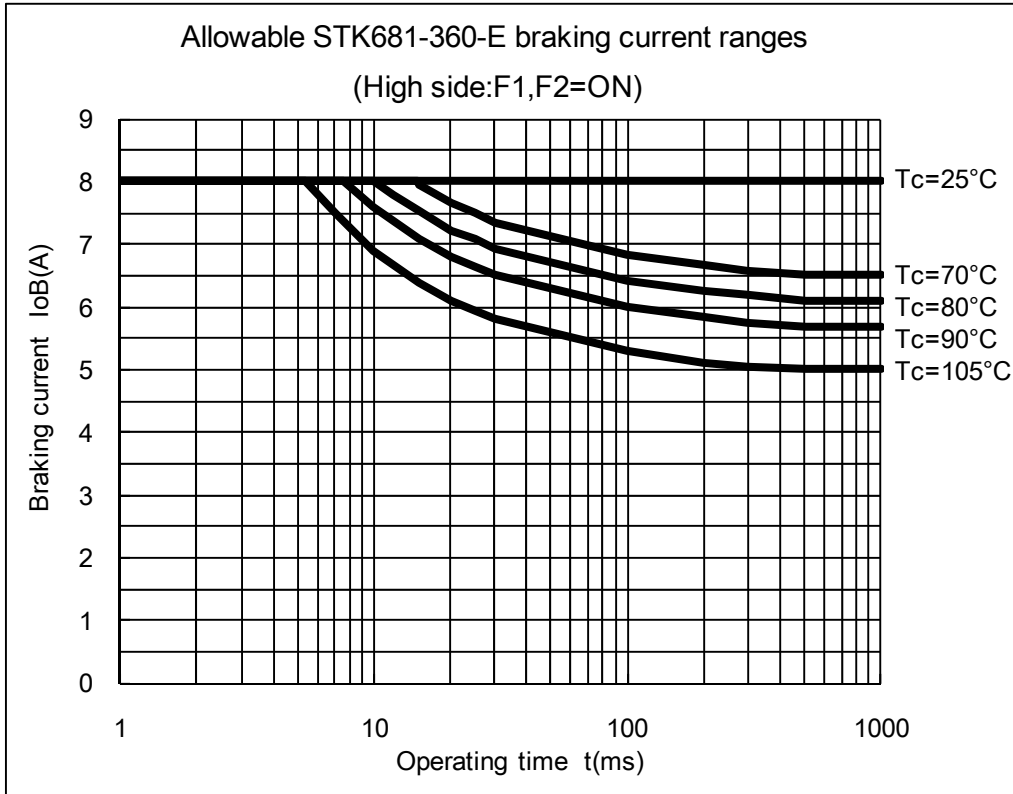

Block Diagram

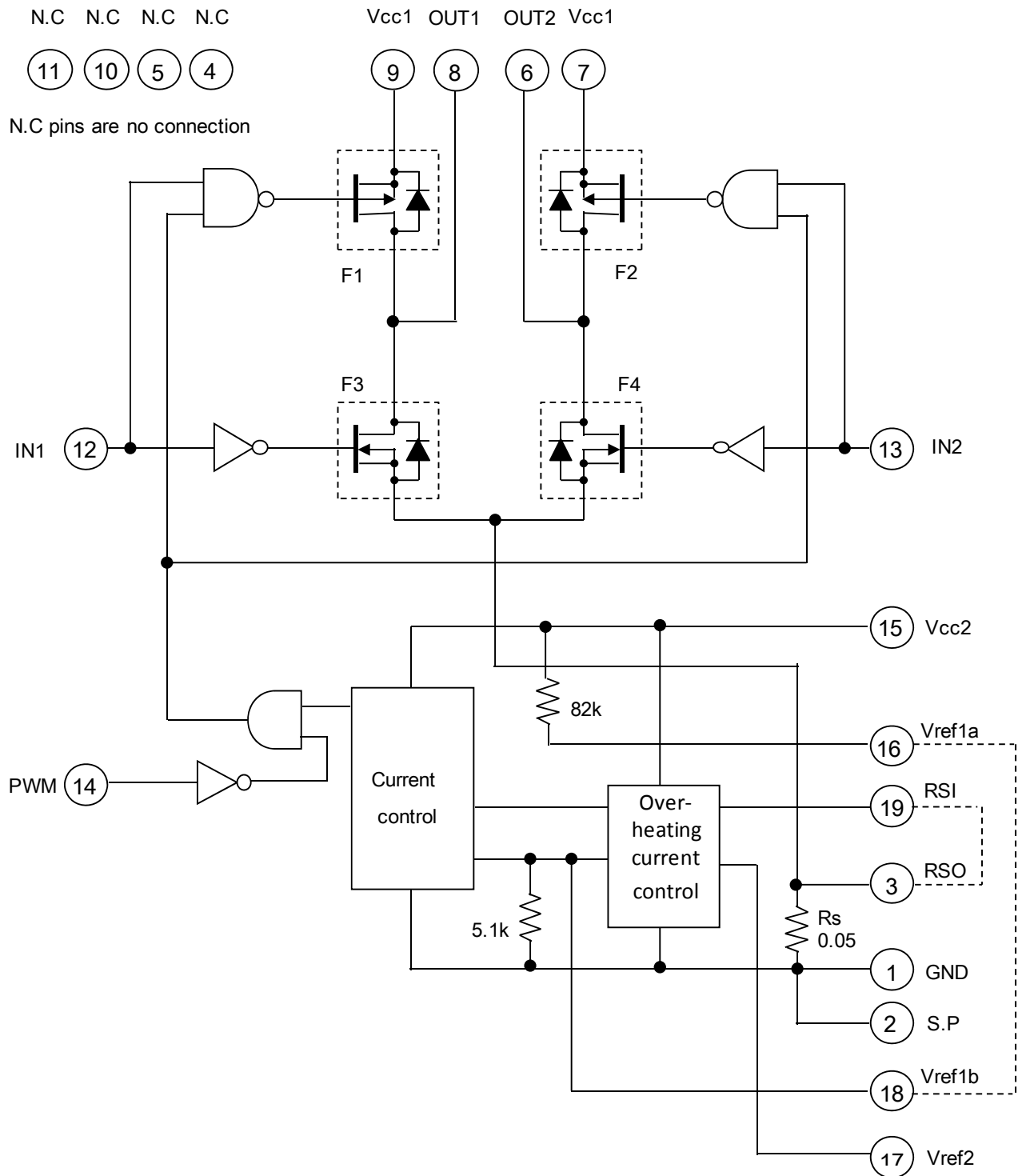

Sample Application Circuit

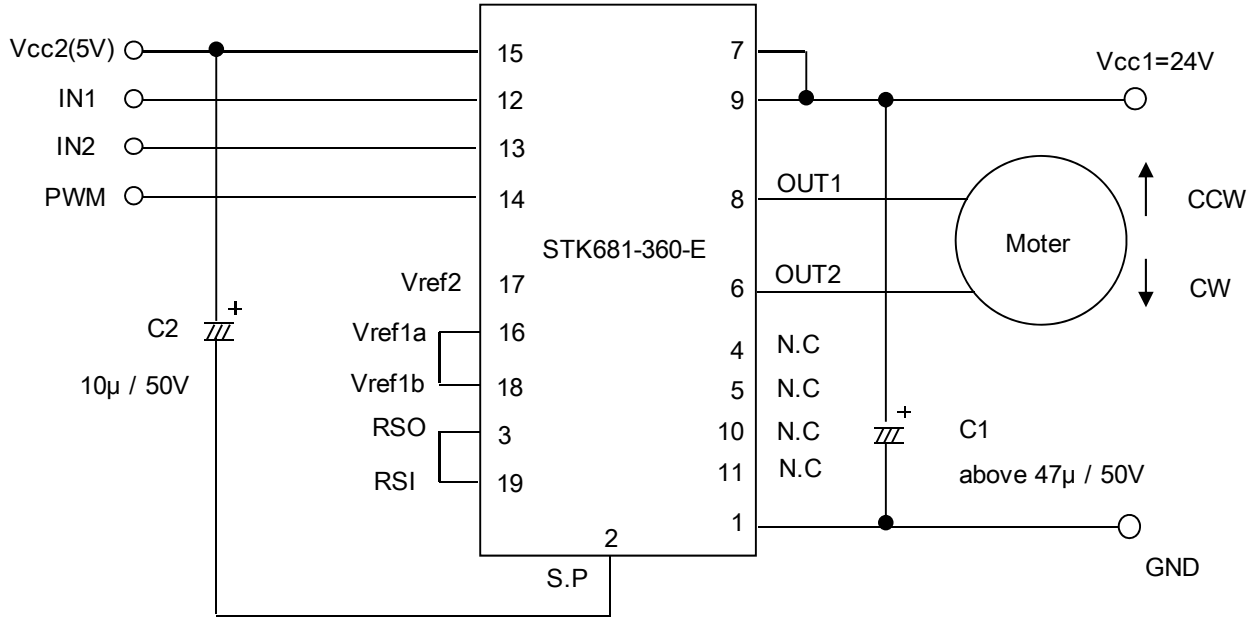

Motor Drive Conditions (H: High-level input; L: Low-Level Input)

	IN1	IN2	PWM	Function
Stop 1 (Standby)	H	H	L or H	The state where the motor is not turning
Stop 2 (Power supply to the motor is off due to an input during motor operation)	H	H	H	Power supply to the motor was turned off due to a stop signal being applied during motor operation.
	H	L	H	
	L	H	H	
Forward(CW)	H	L	L	An input signal that turns off the high and low side drive elements during forward/reverse switching is not required.
Reverse(CCW)	L	H	L	
Brake	L	L	L or H	The ground side MOSFET is in the on state.

* The state IN1 = IN2 = high, PWM = L is illegal during motor operation.

* PWM pin (14pin) is active Low.

Notes

- (1) The value of the power supply bypass capacitor C1 must be set so that the capacitor ripple current, which changes with the motor current, remains within the allowable range.
- (2) While the Vref2 pin is normally handled by being left open, note that the thermal protection circuit will no longer operate if this pin is connected to ground or the P.S pin.
- (3) Current is controlled by a constant-current chopping operation by transistors F1 and F2. The timing for the OUT1 or OUT2 output voltage and the F1 or F2 drain current is shown below.
- (4) Do not connect or wire any of the NC (unused) pins that appear in either the block diagram or the application circuit examples to the circuit pattern on the PCB.

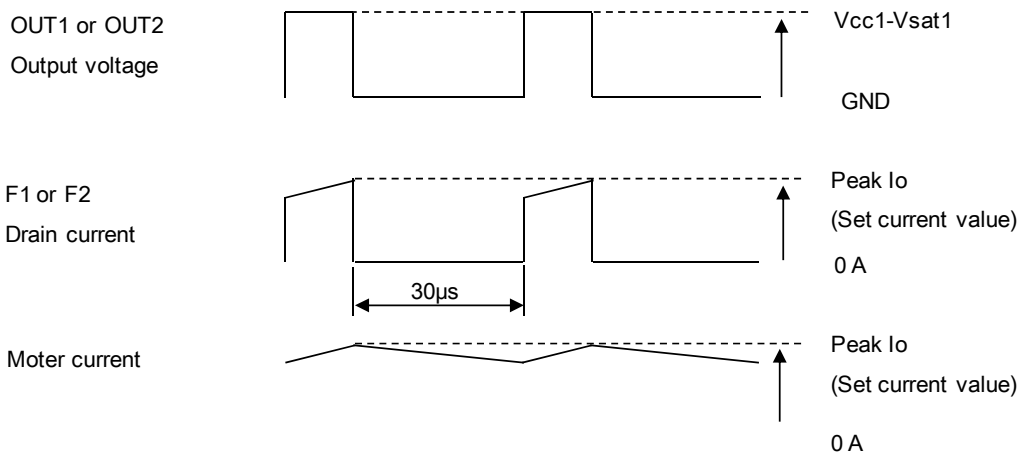

(5) Since the response time of the ground side drive element during forward/reverse direction switching is a few tens of microseconds, this product is not appropriate for H bridge applications. This device should only be used as a DC motor driver.

(6) Timing Charts

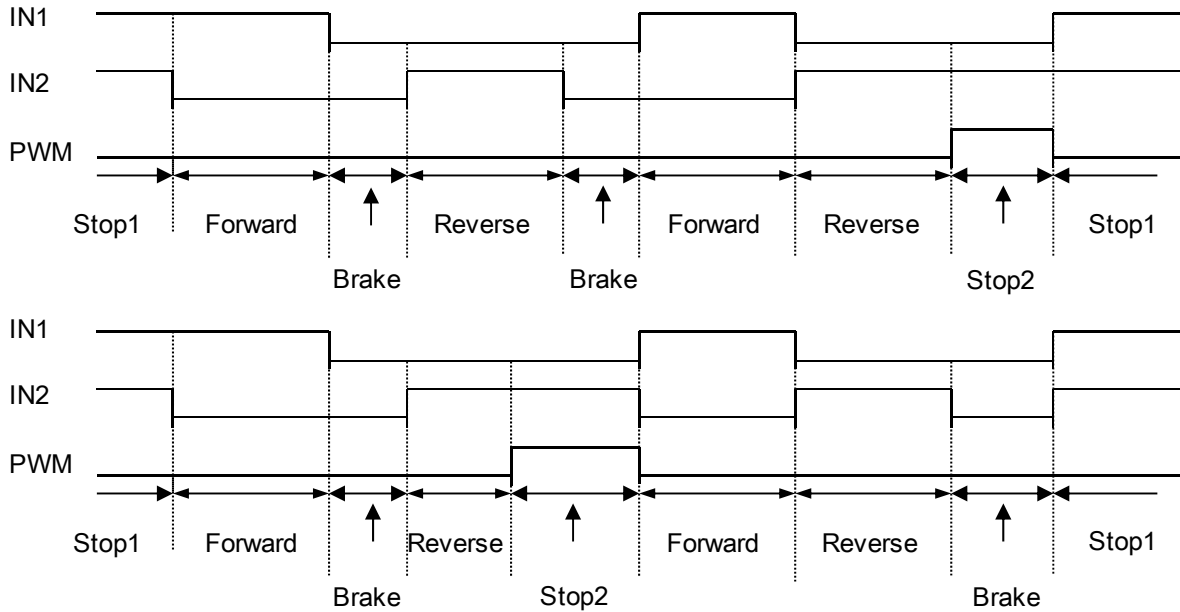

(7) Smoke emission warning: This hybrid IC may emit smoke if it is used under conditions that exceed its specifications.

I/O Functions of Each Pin

Pin name	Pin No	Functions
IN1	12	Input that controls the on/off state of F1 and F3. When high: F1: on, F3: off, when low: F1: off, F3: on.
IN2	13	Input that controls the on/off state of F2 and F4. When high: F2: on, F4: off, when low: F2: off, F4: on.
PWM	14	Input that forces F1 and F2 to the off state: when high F1 and F2 will be off. When low F1 and F2 will be on,
OUT1	8	Motor connection that outputs a source or sink current depending on the states of IN1 and IN2.
OUT2	6	Motor connection that outputs a source or sink current depending on the states of IN1 and IN2.
Vref1a	16	The current setting voltage (Vref1) is used by connecting Vrefa to Vrefb The peak Io level is determined by $I_{o(peak)} = V_{ref1} \div R_s$.
Vref1b	18	
Vref2	17	This pin should normally be left open. Connecting this pin to ground or the S.P pin disables the thermal protection circuit.
S.P	2	The Vref1 voltage can be reduced by connecting a resistor between Vref1 and the S.P pin.
RSO	3	This pin can be used to monitor the voltage across the current detection resistor Rs and is connected to the RSI pin.
RSI	19	Input for the circuit that compares with Vref1. This pin is used connected to the RSO pin.

Configuration of I/O Pin

<IN1,IN2>

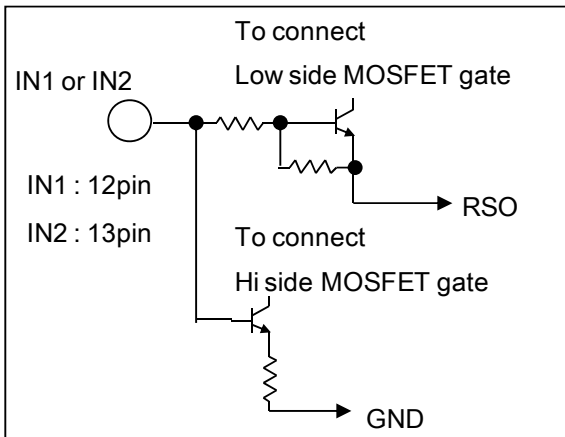

<PWM>

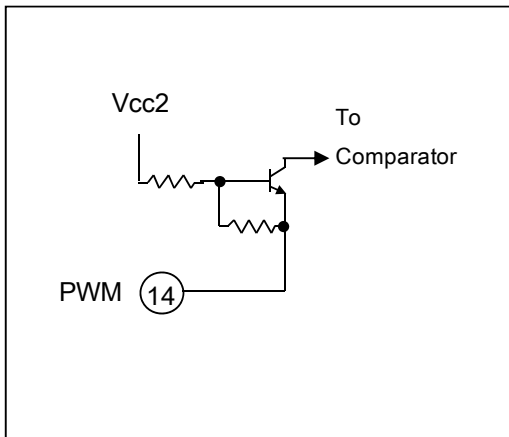

STK681-360-E

Package Dimensions

unit : mm

SIP19 29.2x14.4
CASE 127CF
ISSUE 0

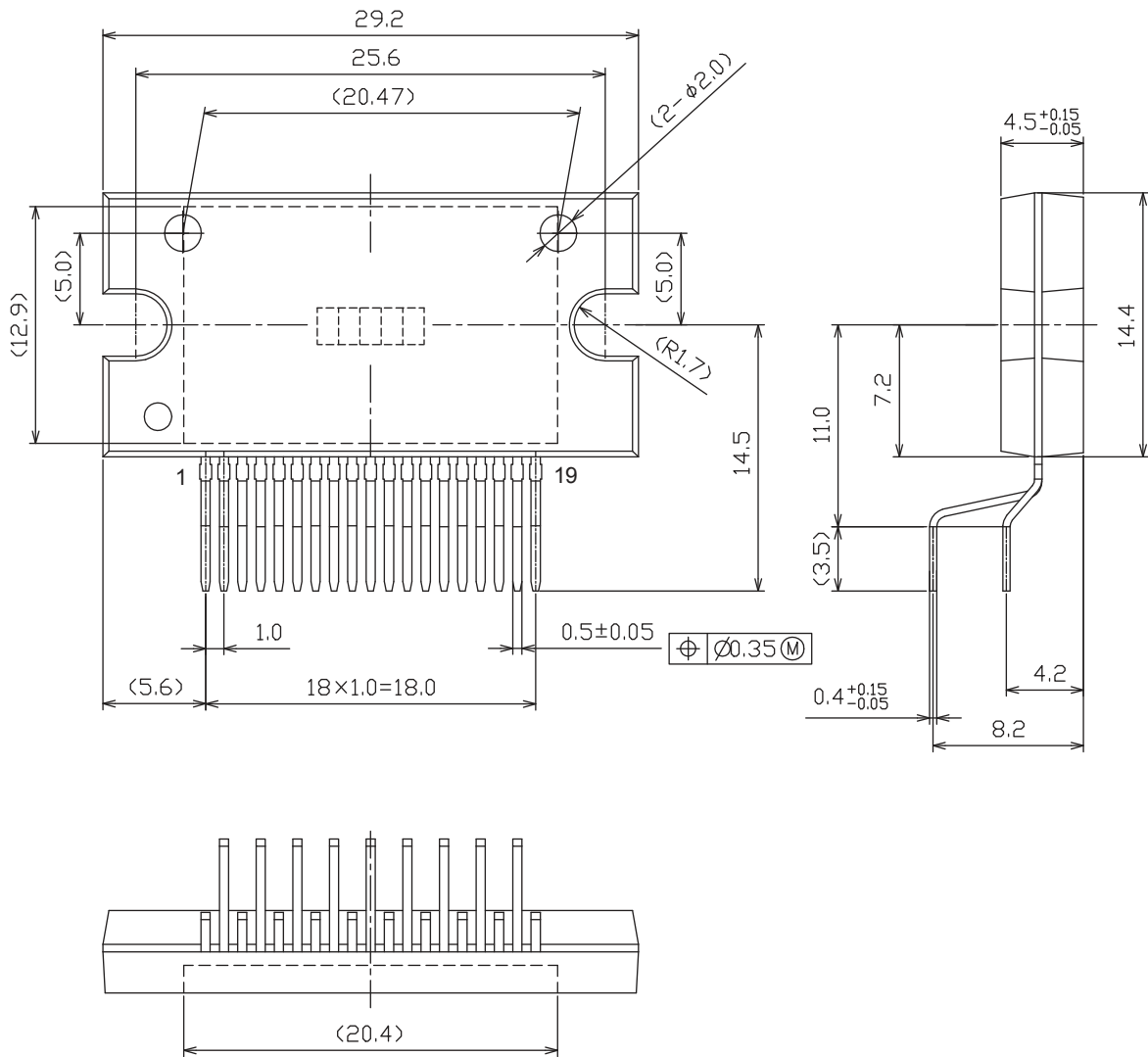

Technical data

1. Substrate temperature rise ΔT_c -Internal average power loss PdAV characteristics
(no heat sink)
2. Average internal power loss (Pd) at DC - motor current (Io) characteristics.
3. Over temperature current suppression characteristics: Io – Tc.
4. Package power loss PdPK derating curve for the ambient temperature Ta.
5. Electrical characteristics
Vdf vs If
Vsat1 , Vsat2 vs Io
6. A.S.O(F1,F2,F3,F4)

STK681-360-E

1. Substrate temperature rise ΔT_c -Internal average power loss P_{dAV} characteristics (no heat sink)

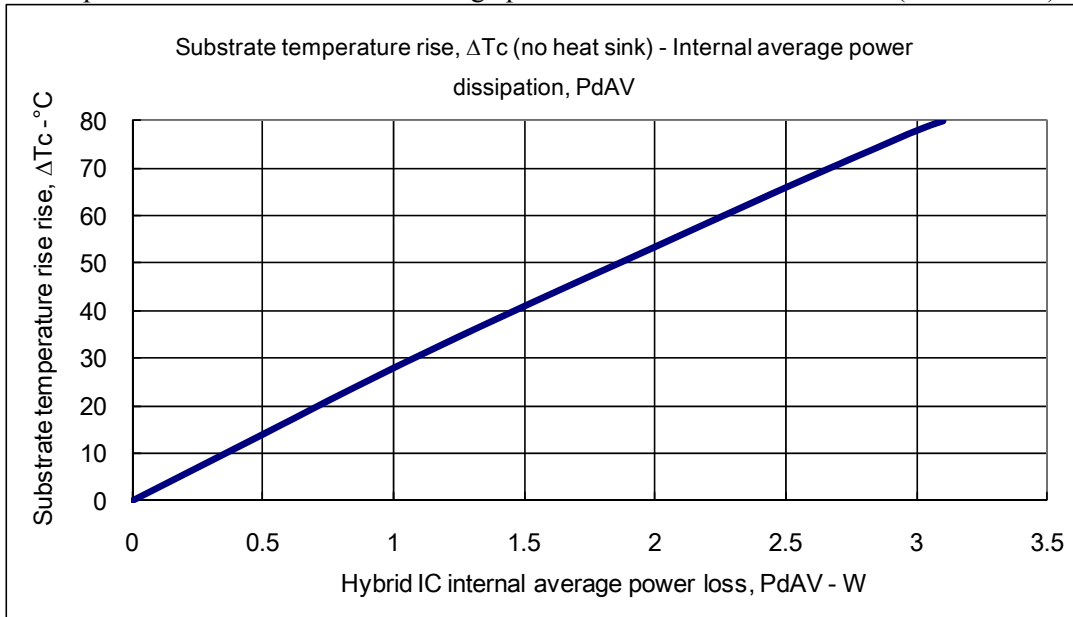

2. Average internal power loss (P_d) at DC - motor current (I_o) characteristics.

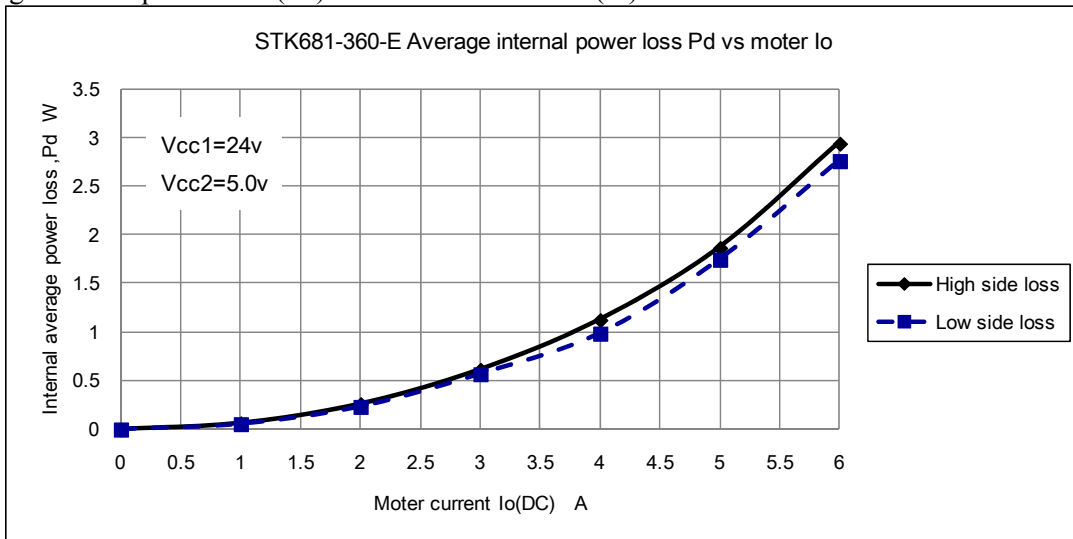

3. Over temperature current suppression characteristics: $I_o - T_c$.

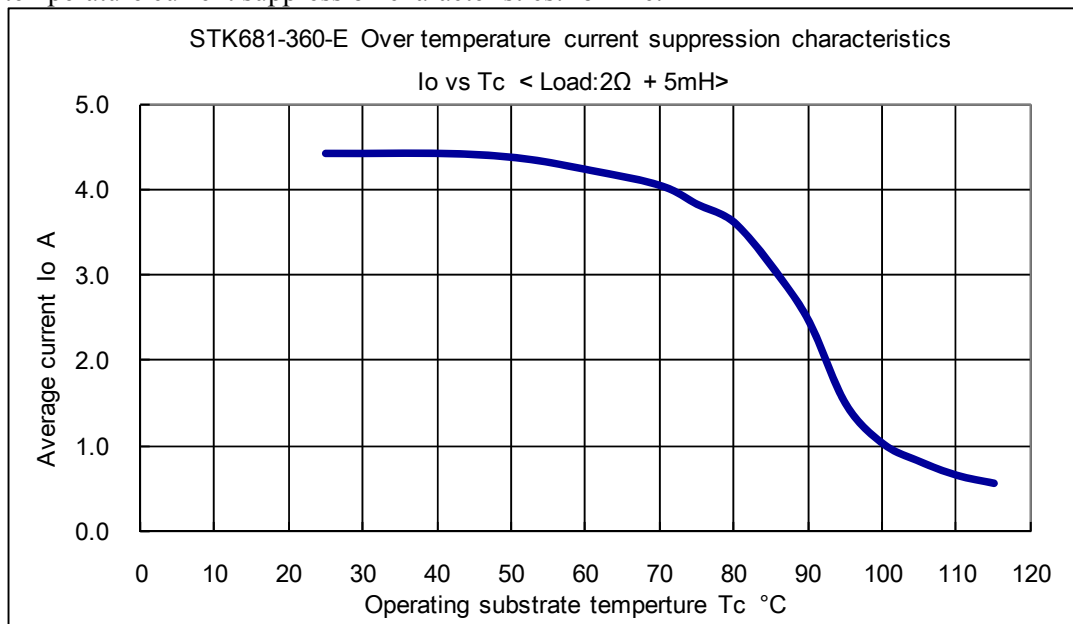

The over temperature current suppression function protects the driver from destruction when an abnormal motor locked (physically constrained) state occurs.

STK681-360-E

4. Package power loss PdPK derating curve for the ambient temperature Ta.

Package power loss, PdPK, refers to the average internal power loss, PdAV, allowable without a heat sink. The figure below represents the allowable power loss, PdPK, vs. fluctuations in the ambient temperature, Ta. Power loss of up to 3.1W is allowable at Ta=25°C, and of up to 1.75W at Ta=60°C.
* The package thermal resistance θ_{c-a} is 25.8°C/W.

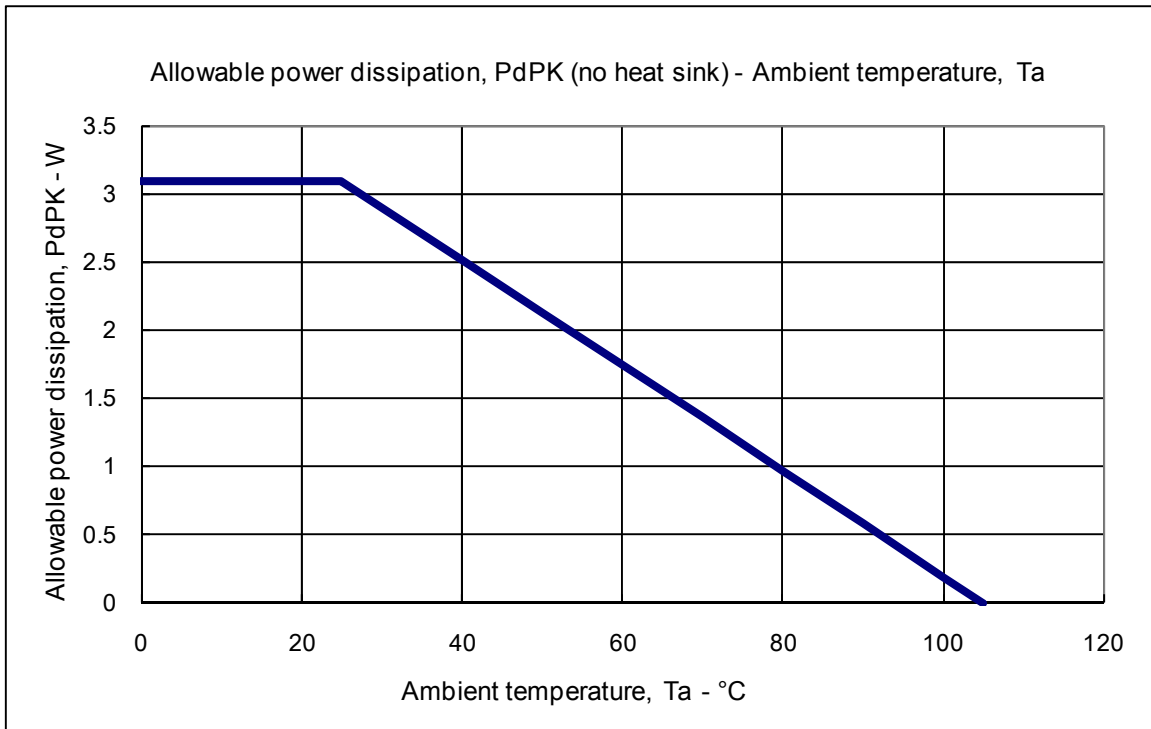

5. Electrical characteristics

<Vdf vs If>

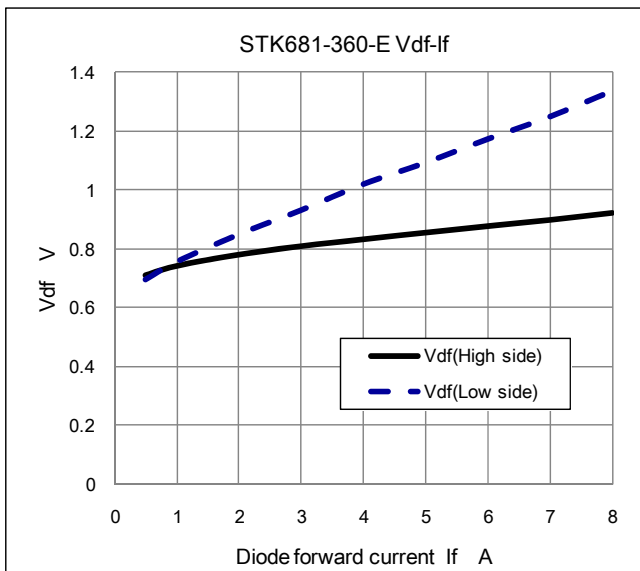

<Vsat1 / Vsat2 vs Io>

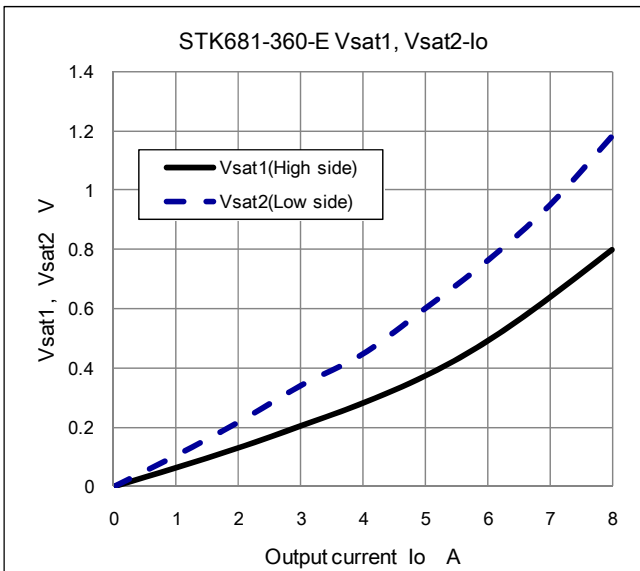

STK681-360-E

7. A.S.O(F1,F2,F3,F4)

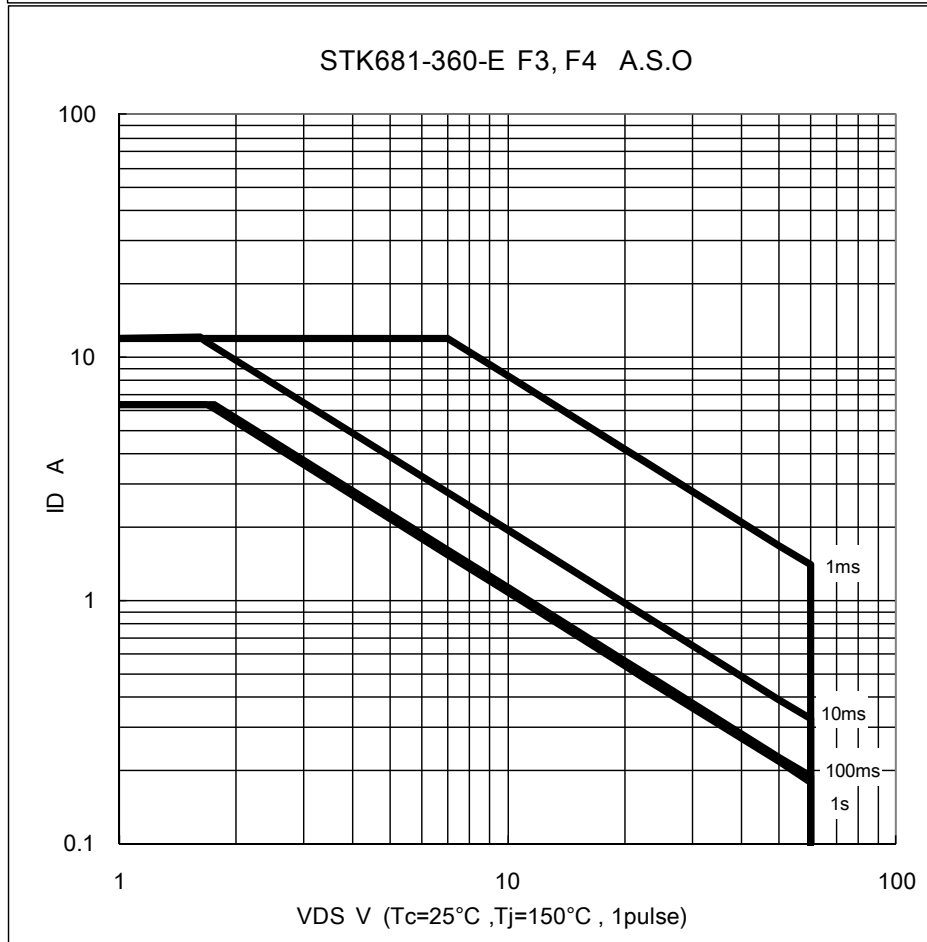
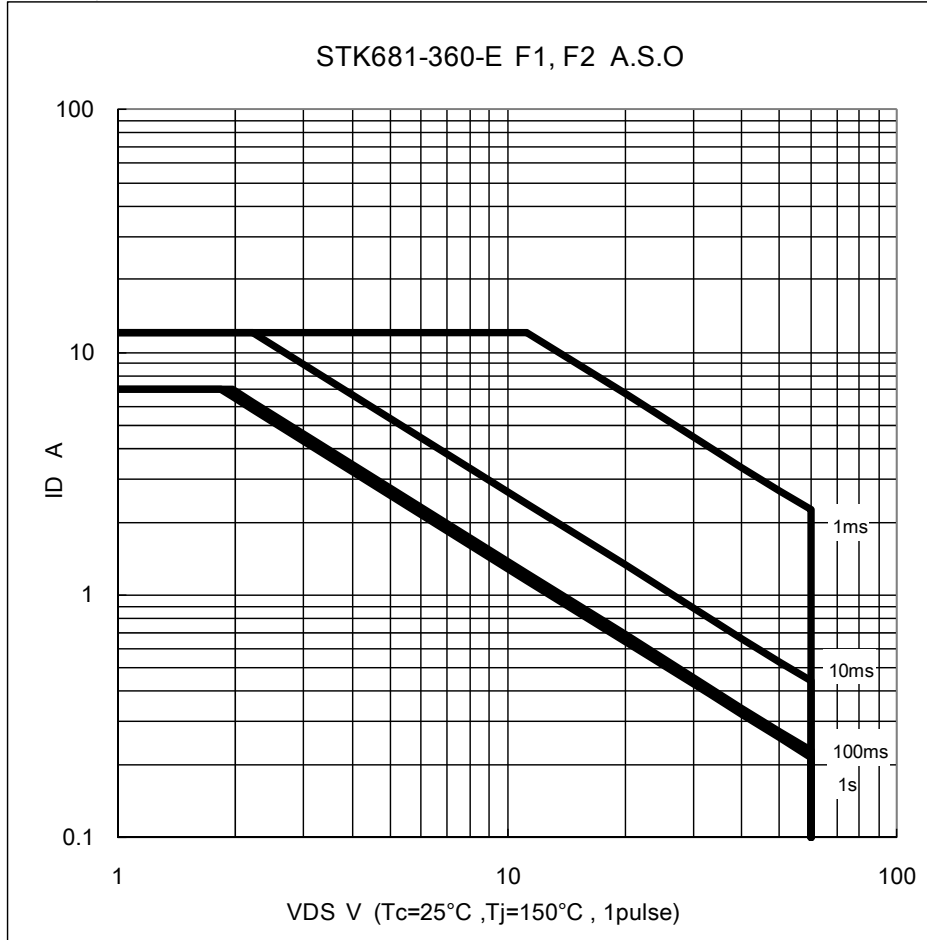

STK681-360-E

ORDERING INFORMATION

Device	Package	Shipping (Qty / Packing)
STK681-360-E	SIP-19 (Pb-Free)	15 / Tube

ON Semiconductor and the ON logo are registered trademarks of Semiconductor Components Industries, LLC (SCILLC). SCILLC owns the rights to a number of patents, trademarks, copyrights, trade secrets, and other intellectual property. A listing of SCILLC's product/patent coverage may be accessed at www.onsemi.com/site/pdf/Patent-Marking.pdf. SCILLC reserves the right to make changes without further notice to any products herein. SCILLC makes no warranty, representation or guarantee regarding the suitability of its products for any particular purpose, nor does SCILLC assume any liability arising out of the application or use of any product or circuit, and specifically disclaims any and all liability, including without limitation special, consequential or incidental damages. "Typical" parameters which may be provided in SCILLC data sheets and/or specifications can and do vary in different applications and actual performance may vary over time. All operating parameters, including "Typicals" must be validated for each customer application by customer's technical experts. SCILLC does not convey any license under its patent rights nor the rights of others. SCILLC products are not designed, intended, or authorized for use as components in systems intended for surgical implant into the body, or other applications intended to support or sustain life, or for any other application in which the failure of the SCILLC product could create a situation where personal injury or death may occur. Should Buyer purchase or use SCILLC products for any such unintended or unauthorized application, Buyer shall indemnify and hold SCILLC and its officers, employees, subsidiaries, affiliates, and distributors harmless against all claims, costs, damages, and expenses, and reasonable attorney fees arising out of, directly or indirectly, any claim of personal injury or death associated with such unintended or unauthorized use, even if such claim alleges that SCILLC was negligent regarding the design or manufacture of the part. SCILLC is an Equal Opportunity/Affirmative Action Employer. This literature is subject to all applicable copyright laws and is not for resale in any manner.