

- Fully Compliant with IrDA 1.1 (4 MBPS)
- Compatible with ASK, HP-SIR and TV Remote
- No Programming Required to Switch Speeds
- Backward Compatible to Slower IrDA Speeds
- Excellent Noise Immunity
- Fully Supportable by all Interface Chips
- Designed to Compensate for Light Loss Caused by Cosmetic Windows

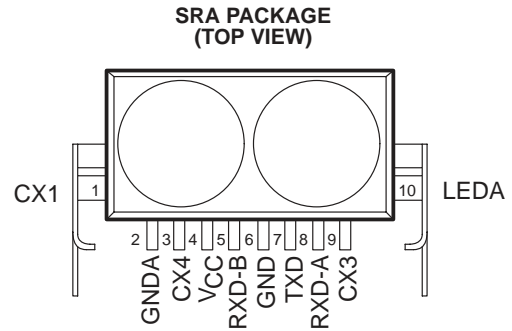

description

The TSLM1100 is an infrared transceiver that provides the interface between logic and IR signals for through-air, serial, half-duplex IR data links. The TSLM1100 is compliant with the Infrared Data Association (IrDA) 1.1 physical-layer specification. Additionally, the TSLM1100 is compatible with ASK, HP-SIR and TV Remote standards.

The TSLM1100 is a hybrid device that includes a high-speed AlGaAs 870-nm LED, a silicon intrinsic PN junction (PIN) diode, and a LinCMOS transceiver integrated circuit. This IC has the LED driver and a receiver that provides two output signals: RXD-A for data rates from 2.4 kb/s to 115.2 kb/s and RXD-B for data rates of 576 kb/s to 4.0 Mb/s.

The device is encapsulated in a visible-light-rejecting plastic package that has integral lenses for the LED and the PIN diode. The receiver lens increases the effective area of the PIN diode to increase sensitivity. The LED lens is designed to provide a beam angle of $\pm 30^\circ$. The receiver outputs pulse low when an IR signal is detected. The power supply for both PIN diode and LED should be filtered to minimize noise from external sources.

This transceiver is well suited for a wide variety of IR interface applications including: PC notebooks, PDAs, pagers, printers, cameras, LANs, telephones and industrial handheld devices.

FUNCTION TABLE

INPUTS		OUTPUTS		
TXD	E_e	$I_e(\text{LED})$	RXD-A	RXD-B
V_{IH}	X	High	NV	NV
V_{IL}	$E_{I(H)}\dagger$	Low	Low	NV
V_{IL}	$E_{I(H)}\ddagger$	Low	NV	Low
V_{IL}	$E_{I(L)}$	Low	High	High

X – don't care, NV – not valid

\dagger Data rates up to 115.2 kb/s

\ddagger Data rates > 115.2 kb/s

TSLM1100

IrDA COMPLIANT TRANSCEIVER

SOES034A – SEPTEMBER 1997 – REVISED OCTOBER 1997

Terminal Functions

PIN		DESCRIPTION
NAME	NO.	
CX1	1	Photodiode bypass capacitor
GND A	2	Analog ground
CX4	3	Averaging capacitor
V _{CC}	4	Supply voltage
RXD-B	5	Receiver data output – Channel B
GND	6	Ground
TXD	7	Transmitter data input
RXD-A	8	Receiver data output – Channel A
CX3	9	Threshold capacitor
LEDA	10	LED anode

absolute maximum ratings over operating free-air temperature (unless otherwise noted)†

Supply voltage, V _{CC}	7 V
LED anode voltage range, V _{I(LEDA)}	–0.5 V to 7 V
Receiver data output voltage range: V _{O(RXD-A)}	–0.5 V to V _{CC} + 0.5 V
V _{O(RXD-B)}	–0.5 V to V _{CC} + 0.5 V
Average LED current, I _{I(LED)(avg)} : Direct current	100 mA
Pulsed, ≤ 90-μs pulse width, ≤ 25% duty cycle	165 mA
Peak LED current, I _{I(LED)(PK)} : ≤ 90-μs pulse width, ≤ 25% duty cycle	660 mA
≤ 2-μs pulse width, ≤ 10% duty cycle	1 A
Transmitter data input current range, I _{I(TXD)}	–12 mA to 12 mA
Storage temperature range, T _{stg}	–20°C to 85°C

† Stresses beyond those listed under “absolute maximum ratings” may cause permanent damage to the device. These are stress ratings only, and functional operation of the device at these or any other conditions beyond those indicated under “recommended operating conditions” is not implied. Exposure to absolute-maximum-rated conditions for extended periods may affect device reliability.

recommended operating conditions

	CONDITIONS	MIN	MAX	UNITS
Supply voltage, V _{CC}		4.75	5.25	V
Logic high transmitter input voltage, V _{IH}		4.25	5.25	V
Logic low transmitter input voltage, V _{IL}		0.0	0.3	V
Logic high receiver input irradiance, E _{e(IH)}	For in-band signals ≤ 116 kb/s	0.0036	500	mW/cm ²
	For in-band signals ≥ 576 kb/s	0.0090	500	mW/cm ²
Logic low receiver input irradiance, E _{e(IL)}	For in-band signals		0.3	μW/cm ²
LED (logic high) Current pulse amplitude, I _{I(LEDA)}		400	660	mA
Receiver setup time	For full sensitivity after transmitting		1.0	ms
Receiver signal rate, RXD-A		2.4	116	kb/s
Receiver signal rate, RXD-B		0.576	4	Mb/s
Ambient light	See IrDA serial infrared physical link specification, 1.1e Appendix A for Ambient levels and Appendix B			
Operating temperature, T _A	Case to ambient thermal resistance ≤ 50°C/W	0	70	°C



POST OFFICE BOX 655303 • DALLAS, TEXAS 75265

electrical characteristics at $V_{CC} = 5\text{ V}$, $T_A = 25^\circ\text{C}$ (unless otherwise noted); test conditions represent worst-case values for the parameters under test

PARAMETER		TEST CONDITIONS	MIN	TYP	MAX	UNIT	
V _{OL}	Low-level output voltage, receiver data	RXD-A			0.5	V	
		RXD-B					
V _{OH}	High-level output voltage, receiver data	RXD-A	V _{CC} - 0.6			V	
		RXD-B					
I _{IL}	Low-level input current, transmitter data	I _{IL} (TXD)	GND ≤ V _{IL} (TXD) ≤ 0.3 V		-2	2	μA
I _{IH}	High-level input current, transmitter data	I _{IH} (TXD)	V _{IH} (TXD) = 4.25 V		40	250	μA
V _T	On-state voltage LED anode	V _T (LEDA)	I _I (LED) = 400 mA at 25°C V _{IH} (TXD) = 4.25 V			2.78	V
I _D (I _{kg})	OFF-state leakage current, LED anode	I _D (I _{kg})(LEDA)	V _I (LEDA) = V _{CC} = 5.25 V V _{IL} (TXD) = 0.3 V			250	μA
I _{CC1}	Supply current, idle state		V _{CC} = 5.25 V V _I (TXD) = V _{IL} , E _e = 0		3	5.1	mA
I _{CC2}	Supply current, active receiver		V _{CC} = 5.25 V V _I (TXD) = V _{IL} , E _e ≤ 500 nW/cm ²		4	18	mA

optical specifications

PARAMETER		CONDITIONS	MIN	TYP	MAX	UNIT
2φ ^{1/2}	Receiver viewing angle		±15			°
	Effective detector area		0.2			cm ²
I _e	Transmitter radiant intensity, logic high	V _{IH} (TXD) = 4.25 V I _I (LED) = 450 mA, φ ^{1/2} ≤ 15°, T _A = 25°C	100	177		mW/sr
		V _{IH} (TXD) = 4.25 V I _I (LED) = 450 mA, φ ^{1/2} ≤ 15°, 0°C ≤ T _A ≤ 70°C	80	177		mW/sr
λ _p	Transmitter peak-emission wavelength		875			nm
Δλ ^{1/2}	Transmitter spectral-line half-width		35			nm
2φ ^{1/2}	Transmitter viewing angle		±15		±30	°
	Receiver peak-emission sensitivity wave length		880			nm

TSLM1100

IrDA COMPLIANT TRANSCEIVER

SOES034A – SEPTEMBER 1997 – REVISED OCTOBER 1997

switching characteristics

PARAMETER		TEST CONDITIONS	MIN	TYP	MAX	UNIT
$I_e(PW)$	Transmitter radiant intensity pulse width	$I_e(PW)(TXD) = 1.6 \mu s$ at 115.2k pulses/s	1.5	1.6	1.8	μs
		$I_e(PW)(TXD) = 125 ns$ at 2M pulses/s	115	125	135	ns
I_e	Transmitter radiant intensity	$I_e(PW)(TXD) = 125 ns$ at 2M pulses/s			40	ns
			Rise time			
PW	Pulse width	RXD-A			7.5	μs
		RXD-B	$\phi 1/2 \leq 15^\circ$		185	ns
PW	Pulse width, RXD-B (ASK)	500 kHz, 50% duty cycle carrier ASK	0.7	1	1.3	μs
t_L	Receiver latency time	RXD-A			0.5	ms
		RXD-B				

APPLICATION INFORMATION

schematic

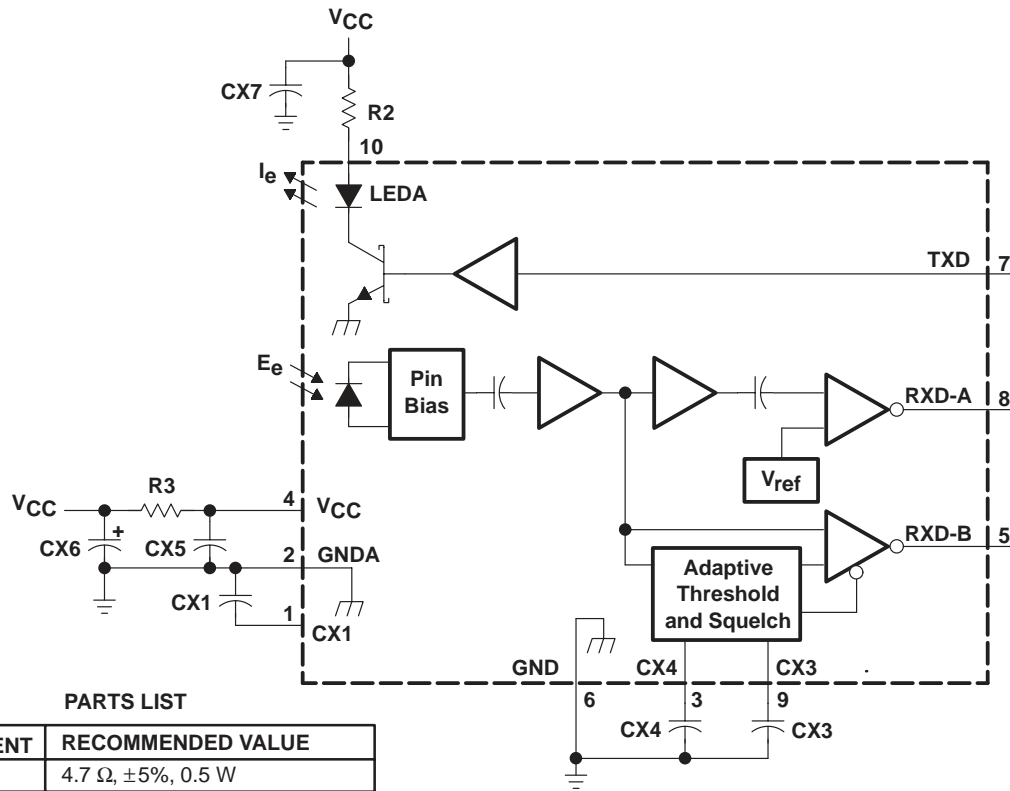

PARTS LIST

COMPONENT	RECOMMENDED VALUE
R2	4.7 Ω , $\pm 5\%$, 0.5 W
R3	10 Ω , $\pm 5\%$, 0.125 W
CX1†	0.47 μF , $\pm 10\%$, X7R Ceramic
CX3	4700 pF, $\pm 10\%$, X7R Ceramic
CX4	0.010 μF , $\pm 10\%$, X7R Ceramic
CX5†	0.47 μF , $\pm 20\%$, X7R Ceramic
CX6	6.8 μF , Tantalum
CX7	0.47 μF , $\pm 20\%$, X7R Ceramic

† CX1 and CX5 must be placed within 0.7 cm of the TSLM1100 to obtain optimum noise immunity.

MECHANICAL DATA

SRA (R-PSIP-T8)

PLASTIC SMALL-OUTLINE PACKAGE

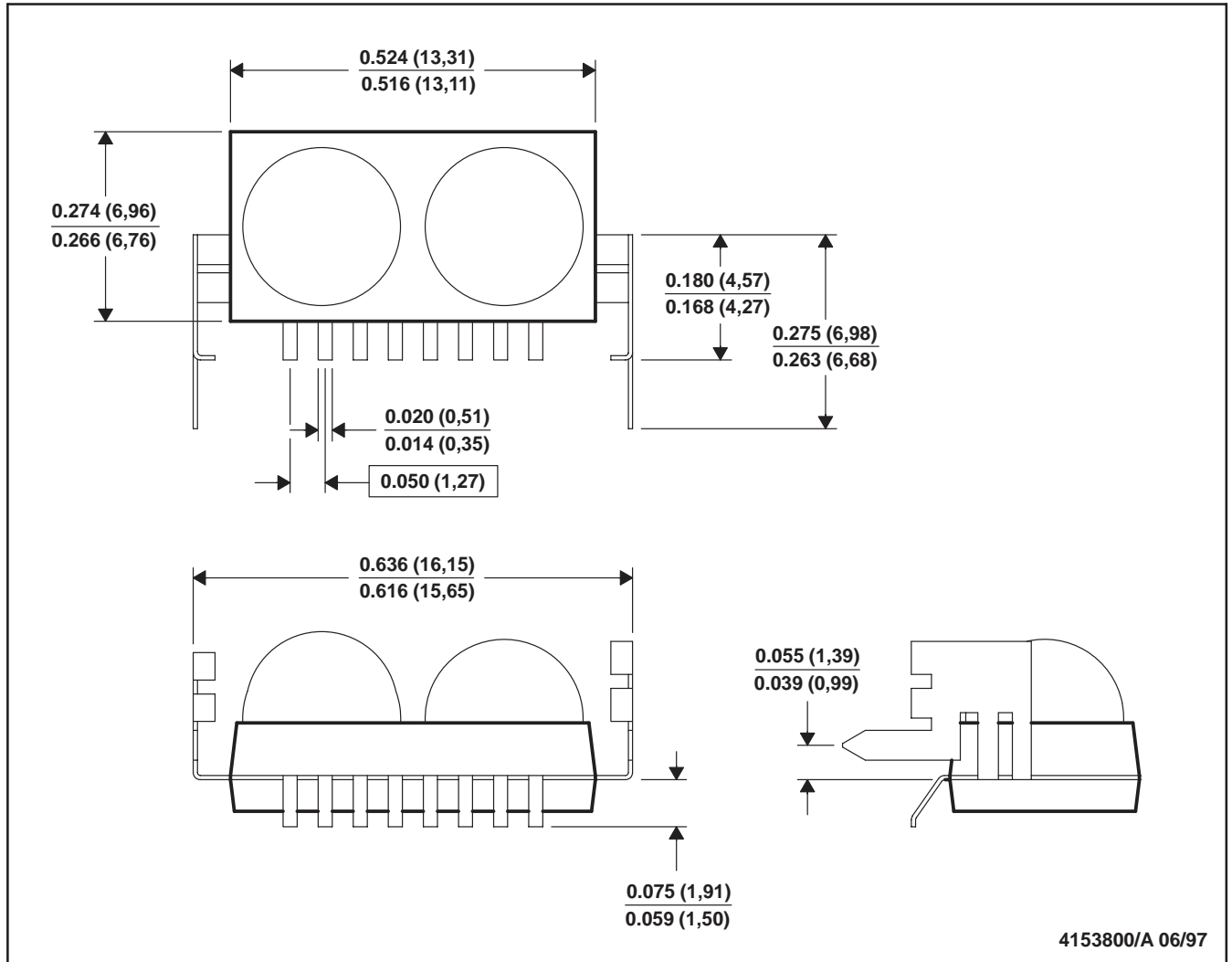

- NOTES: A. All linear dimensions are in inches (millimeters).
B. This drawing is subject to change without notice.

PACKAGING INFORMATION

Orderable Device	Status ⁽¹⁾	Package Type	Package Drawing	Pins	Package Qty	Eco Plan ⁽²⁾	Lead/Ball Finish	MSL Peak Temp ⁽³⁾
TSLM1100	OBSOLETE	OPTO	SRA	10		TBD	Call TI	Call TI

⁽¹⁾ The marketing status values are defined as follows:

ACTIVE: Product device recommended for new designs.

LIFEBUY: TI has announced that the device will be discontinued, and a lifetime-buy period is in effect.

NRND: Not recommended for new designs. Device is in production to support existing customers, but TI does not recommend using this part in a new design.

PREVIEW: Device has been announced but is not in production. Samples may or may not be available.

OBSOLETE: TI has discontinued the production of the device.

⁽²⁾ Eco Plan - The planned eco-friendly classification: Pb-Free (RoHS) or Green (RoHS & no Sb/Br) - please check <http://www.ti.com/productcontent> for the latest availability information and additional product content details.

TBD: The Pb-Free/Green conversion plan has not been defined.

Pb-Free (RoHS): TI's terms "Lead-Free" or "Pb-Free" mean semiconductor products that are compatible with the current RoHS requirements for all 6 substances, including the requirement that lead not exceed 0.1% by weight in homogeneous materials. Where designed to be soldered at high temperatures, TI Pb-Free products are suitable for use in specified lead-free processes.

Green (RoHS & no Sb/Br): TI defines "Green" to mean Pb-Free (RoHS compatible), and free of Bromine (Br) and Antimony (Sb) based flame retardants (Br or Sb do not exceed 0.1% by weight in homogeneous material)

⁽³⁾ MSL, Peak Temp. -- The Moisture Sensitivity Level rating according to the JEDEC industry standard classifications, and peak solder temperature.

Important Information and Disclaimer:The information provided on this page represents TI's knowledge and belief as of the date that it is provided. TI bases its knowledge and belief on information provided by third parties, and makes no representation or warranty as to the accuracy of such information. Efforts are underway to better integrate information from third parties. TI has taken and continues to take reasonable steps to provide representative and accurate information but may not have conducted destructive testing or chemical analysis on incoming materials and chemicals. TI and TI suppliers consider certain information to be proprietary, and thus CAS numbers and other limited information may not be available for release.

In no event shall TI's liability arising out of such information exceed the total purchase price of the TI part(s) at issue in this document sold by TI to Customer on an annual basis.

IMPORTANT NOTICE

Texas Instruments Incorporated and its subsidiaries (TI) reserve the right to make corrections, modifications, enhancements, improvements, and other changes to its products and services at any time and to discontinue any product or service without notice. Customers should obtain the latest relevant information before placing orders and should verify that such information is current and complete. All products are sold subject to TI's terms and conditions of sale supplied at the time of order acknowledgment.

TI warrants performance of its hardware products to the specifications applicable at the time of sale in accordance with TI's standard warranty. Testing and other quality control techniques are used to the extent TI deems necessary to support this warranty. Except where mandated by government requirements, testing of all parameters of each product is not necessarily performed.

TI assumes no liability for applications assistance or customer product design. Customers are responsible for their products and applications using TI components. To minimize the risks associated with customer products and applications, customers should provide adequate design and operating safeguards.

TI does not warrant or represent that any license, either express or implied, is granted under any TI patent right, copyright, mask work right, or other TI intellectual property right relating to any combination, machine, or process in which TI products or services are used. Information published by TI regarding third-party products or services does not constitute a license from TI to use such products or services or a warranty or endorsement thereof. Use of such information may require a license from a third party under the patents or other intellectual property of the third party, or a license from TI under the patents or other intellectual property of TI.

Reproduction of information in TI data books or data sheets is permissible only if reproduction is without alteration and is accompanied by all associated warranties, conditions, limitations, and notices. Reproduction of this information with alteration is an unfair and deceptive business practice. TI is not responsible or liable for such altered documentation.

Resale of TI products or services with statements different from or beyond the parameters stated by TI for that product or service voids all express and any implied warranties for the associated TI product or service and is an unfair and deceptive business practice. TI is not responsible or liable for any such statements.

Following are URLs where you can obtain information on other Texas Instruments products and application solutions:

Products		Applications	
Amplifiers	amplifier.ti.com	Audio	www.ti.com/audio
Data Converters	dataconverter.ti.com	Automotive	www.ti.com/automotive
DSP	dsp.ti.com	Broadband	www.ti.com/broadband
Interface	interface.ti.com	Digital Control	www.ti.com/digitalcontrol
Logic	logic.ti.com	Military	www.ti.com/military
Power Mgmt	power.ti.com	Optical Networking	www.ti.com/opticalnetwork
Microcontrollers	microcontroller.ti.com	Security	www.ti.com/security
		Telephony	www.ti.com/telephony
		Video & Imaging	www.ti.com/video
		Wireless	www.ti.com/wireless

Mailing Address: Texas Instruments
Post Office Box 655303 Dallas, Texas 75265