

K500 Series, Rated up to 500 Amps, 28 Vdc



Performance Data

Electrical Characteristics

- Main Contacts** —
- Contact Arrangement** — SPST NO, Double Break
- Rated Operating Voltage** — 28 Vdc
- Resistive Rating** — 500 Amps
- Rupture Rating** — 5,000 Amps
- Auxiliary Contacts** —
- Aux. Contact Arrangement** — 3 SPDT
- Rated Operating Voltage** — 28 Vdc
- Resistive Rating** — 5 Amps
- Lamp Rating** — 1 Amps
- Low Level** — 1 mA @ 28 Vdc

General Characteristics

- Temperature Range** — -55°C to +85°C
- Operating Cycles (Life) at Rated Resistive Load** — 50,000 cycles
- Operating Cycles (Life) Mechanical** — 100,000 cycles
- Altitude** — 50,000 ft.
- Weight, Max.** — .88 lbs
- Operate Time @ 18 Vdc & 85°C, Max.** — 45 msec
- Dropout Time @ 32 Vdc, Max.** — 25 msec

Coil Characteristics

- Duty Cycle** — Continuous, economizing
- Operating Voltage, Nom.** — 28 Vdc
- Pickup Voltage, Max.** — 18 Vdc
- Dropout Voltage** — 1 to 7 Vdc
- Inrush** — 5 Amps
- Hold @ 32 Vdc & -55°C** — 0.272 mA max.

Product Facts

- SPST NO, Double break
- Buss bar or chassis mount designs
- Gasket sealed
- Multiple auxiliary contact choices
- Meets many requirements of MIL-PRF-6106

Coil Type

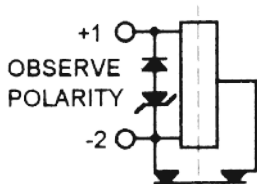

A — Economized with Suppression

K500 Series, Rated up to 500 Amps, 28 Vdc (Continued)

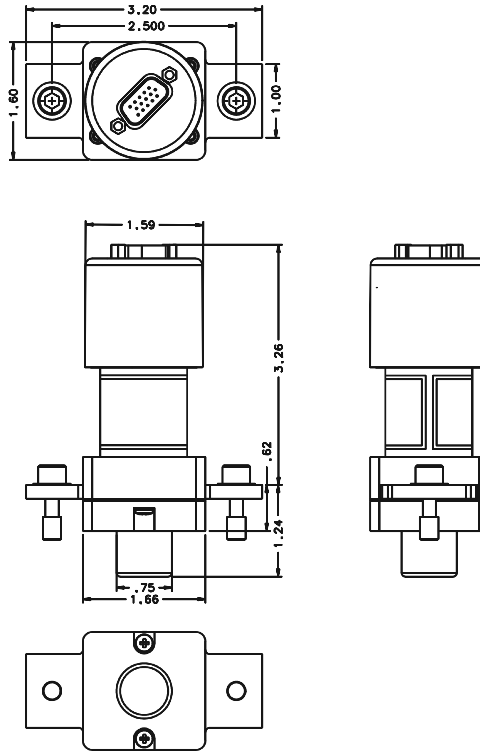

Mounting Style A

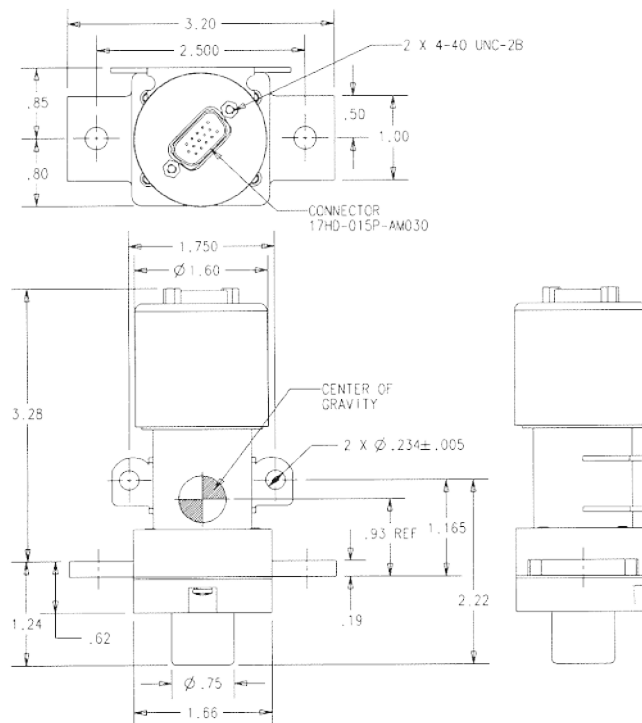

Mounting Style B

For factory-direct application assistance, phone 419-521-9500 or fax 419-526-2749.

K500 Series, Rated up to 500 Amps, 28 Vdc (Continued)

Circuit Configurations (Consult TE for other available circuit configurations)

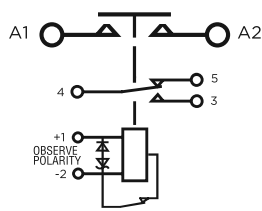

Circuit Configuration 1

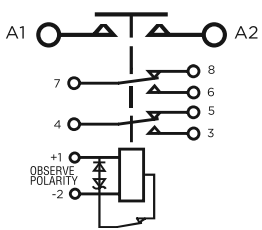

Circuit Configuration 2

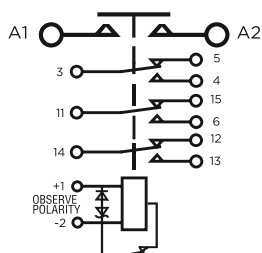

Circuit Configuration 3

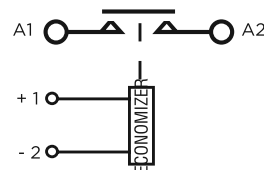

Circuit Configuration 4

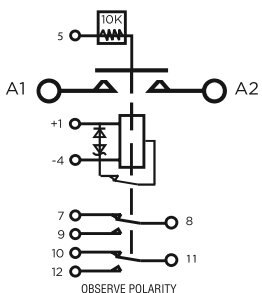

Circuit Configuration 5

HARTMAN Part No.	Mounting Style	Coil Type	Circuit Configuration	TE Part No.
K500B2C	Bus Bar Mount	Economized with Suppression	1	7-1616927-0
K500A2C	Chassis Mount		1	4-1616951-4
K500B3C	Bus Bar Mount		2	7-1616970-0
K500A3C	Chassis Mount		2	6-1616970-9
K500B7C01	Bus Bar Mount		3	9-1616965-0
K500A7C01	Chassis Mount	3	2-1616970-8	
K500A1C	Chassis Mount	4	1-1616992-7	
K500B1C	Bus Bar Mount	4	2-1616992-8	
K500B3C02	Bus Bar Mount	5	7-2252003-3	

K Series, Rated up to 500 Amps, 28 Vdc — Time Delay

Product Facts

- SPST NO, Double break
- Delay on operator or release
- Chassis Mount (bus bar mount available)
- Gasket sealed
- Meets many requirements of MIL-PRF-6106

Performance Data

Electrical Characteristics

- Contact Arrangement — SPST NO, Double Break
- Rated Operating Voltage — 28 VDC
- Resistive Rating — 500A
- Rupture Rating — 5000A
- Delay on operate or release — See note 1

General Characteristics

- Temperature Range — -55°C to +85°C
- Minimum Electrical Cycles — 50,000
- Minimum Mechanical Cycles — 100,000 @ 125A
- Dielectric Strength — 1000 Vrms
- Altitude — 50,000 ft
- Weight, Max. — 1.0 lbs
- Duty Cycle — Intermittent or Continuous (See note 2)
- Operating Voltage Range — 21 - 32 Vdc
- Drop Out Voltage — 1 to 7 Vdc

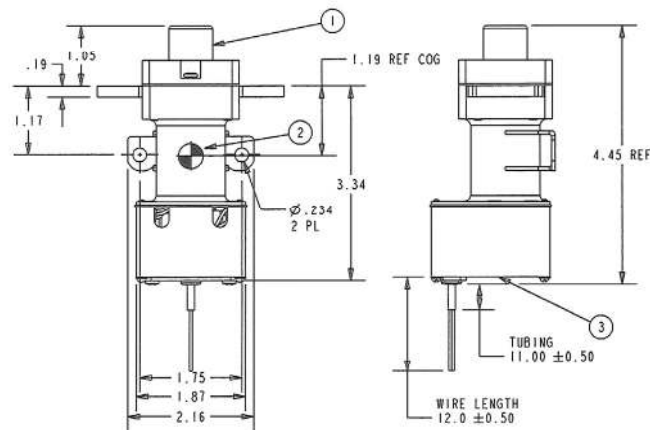
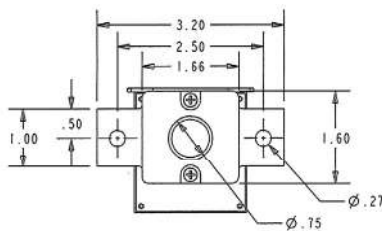

NOTES

1. Delay can be tailored to meet customer need. Consult Factory.
2. Intermittent duty coil is recommended for starting applications where significant control voltage sags are possible. Consult factory to specify correct coil duty for your application.

For factory-direct application assistance, phone 419-521-9500 or fax 419-526-2749.