

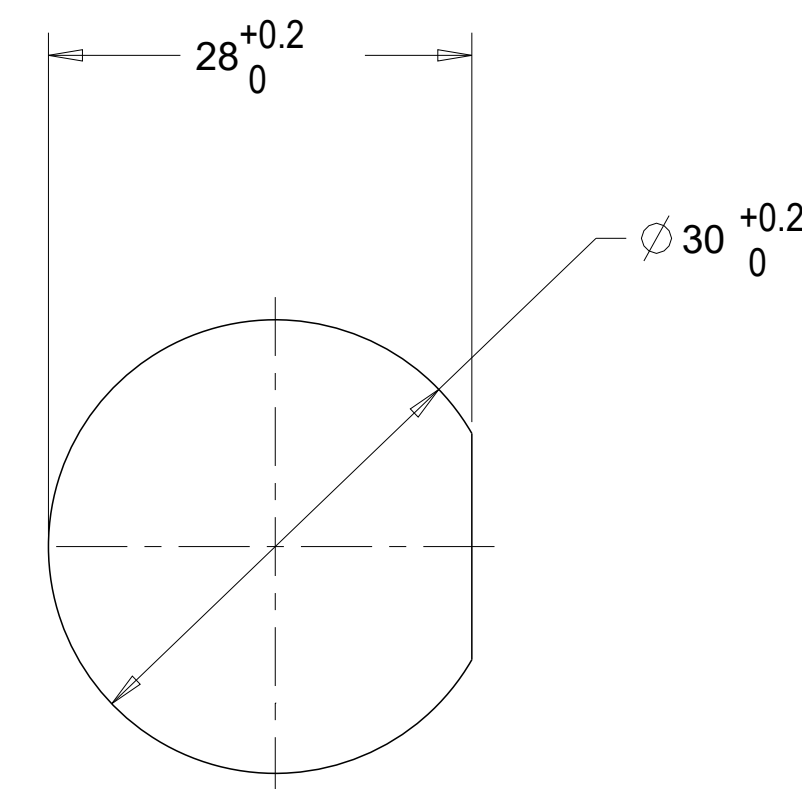

REVISIONS					
P	LTR	DESCRIPTION	DATE	DWN	APVD
B		ECR-16-004825	07APR2016	KG	DW
C		ECR-16-006882	18MAY2016	KG	DW
D		ECR-17-012188	12SEP2017	KG	DW
D1		ECR-20-004620	31MAR2020	TS	DW

1. ASSEMBLY SHOWN FOR REFERENCE ONLY. SHIPPED LOOSE PIECE AS SHOWN ON PAGE 2.
2. ALL ASSEMBLY DIMENSIONS ARE FOR REFERENCE ONLY.
3.  PANEL THICKNESS: 1mm MINIMUM, 6.5mm MAXIMUM.
4. COMPLETE THE CONNECTOR ASSEMBLY BY ADDING EACH OF THE FOLLOWING PRO BEAM JR KITS:
 - A. EXPANDED BEAM INSERT ASSEMBLY KIT
 - B. FERRULE KIT, ONE PER FIBER

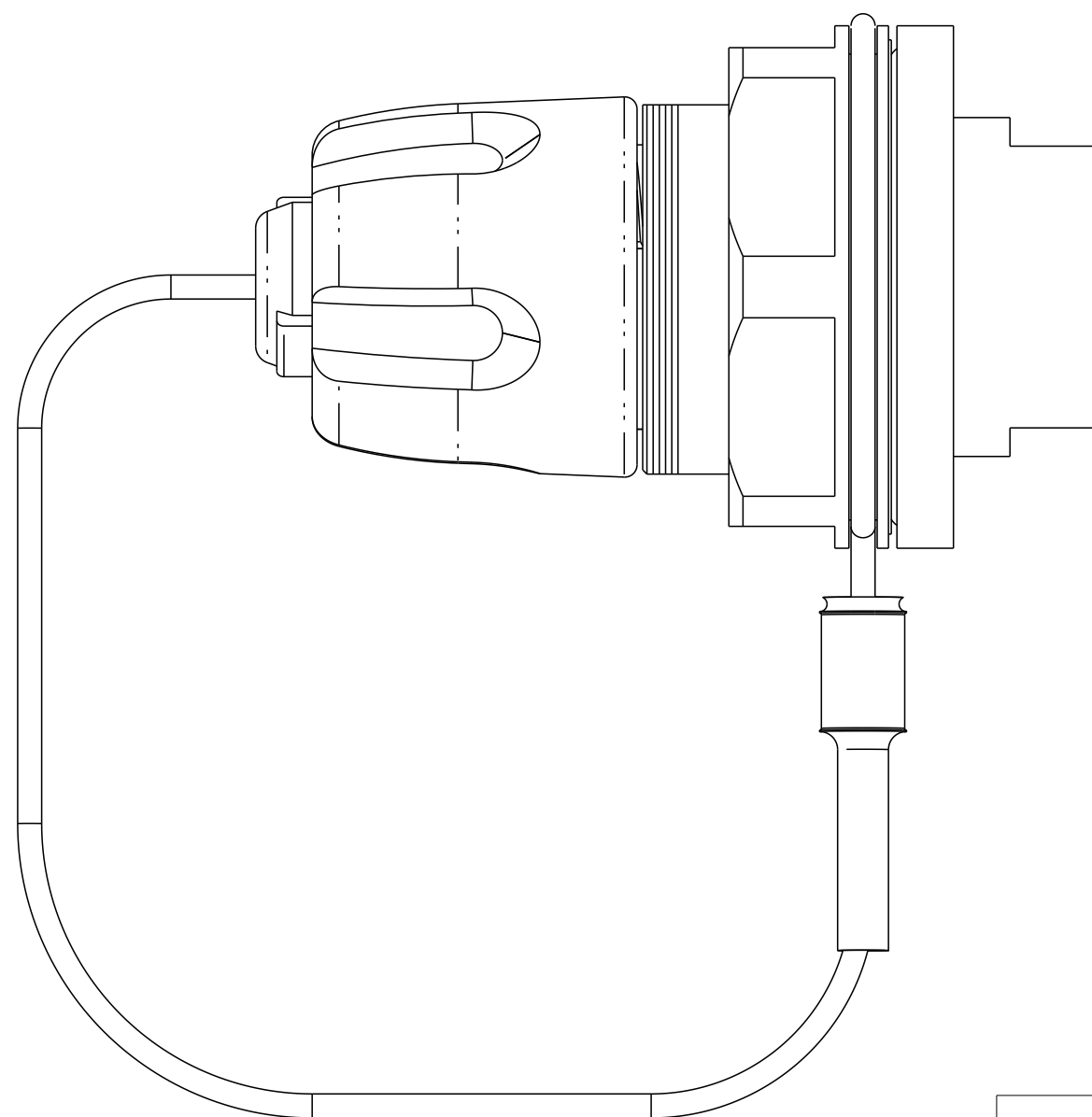

 RECOMMENDED PANEL CUT-OUT

1, 2 & 3	NICKEL ALUMINUM BRONZE	NONE	6828413-6
1, 2 & 3	ALUMINUM	BLACK Zn-Ni	6828413-5
1, 2 & 3	ALUMINUM	HARD ANODIZE	6828413-4
2 & 4	NICKEL ALUMINUM BRONZE	NONE	6828413-3
2 & 4	ALUMINUM	BLACK Zn-Ni	6828413-2
2 & 4	ALUMINUM	HARD ANODIZE	6828413-1
INSERT CHANNEL APPLICATION	HOUSING ALLOY	FINISH	PART NUMBER

THIS DRAWING IS A CONTROLLED DOCUMENT.		DWN K.GLATFELTER 08JUN2006	 TE Connectivity	
		CHK D. WERTMAN 14JUN2006		
		APVD D. WERTMAN 14JUN2006	NAME CONNECTOR SHELL KIT, PRO BEAM JR. D-HOLE LP BULKHEAD, 2.1mm	
DIMENSIONS: mm		PRODUCT SPEC -	SIZE A2	CAGE CODE 00779
TOLERANCES UNLESS OTHERWISE SPECIFIED: 0 PLC ± 1 PLC ± 2 PLC ± 3 PLC ± 4 PLC ± ANGLES ± FINISH		APPLICATION SPEC -	DRAWING NO 6828413	RESTRICTED TO -
MATERIAL -		WEIGHT -	SCALE 2:1 SHEET 1 OF 2 REV D1	
SEE TABLE		CUSTOMER DRAWING		

REVISIONS					
P	LTR	DESCRIPTION	DATE	DWN	APVD
-		SEE SHEET 1	-	-	-

1. SHIPPED LOOSE PIECE AS SHOWN.

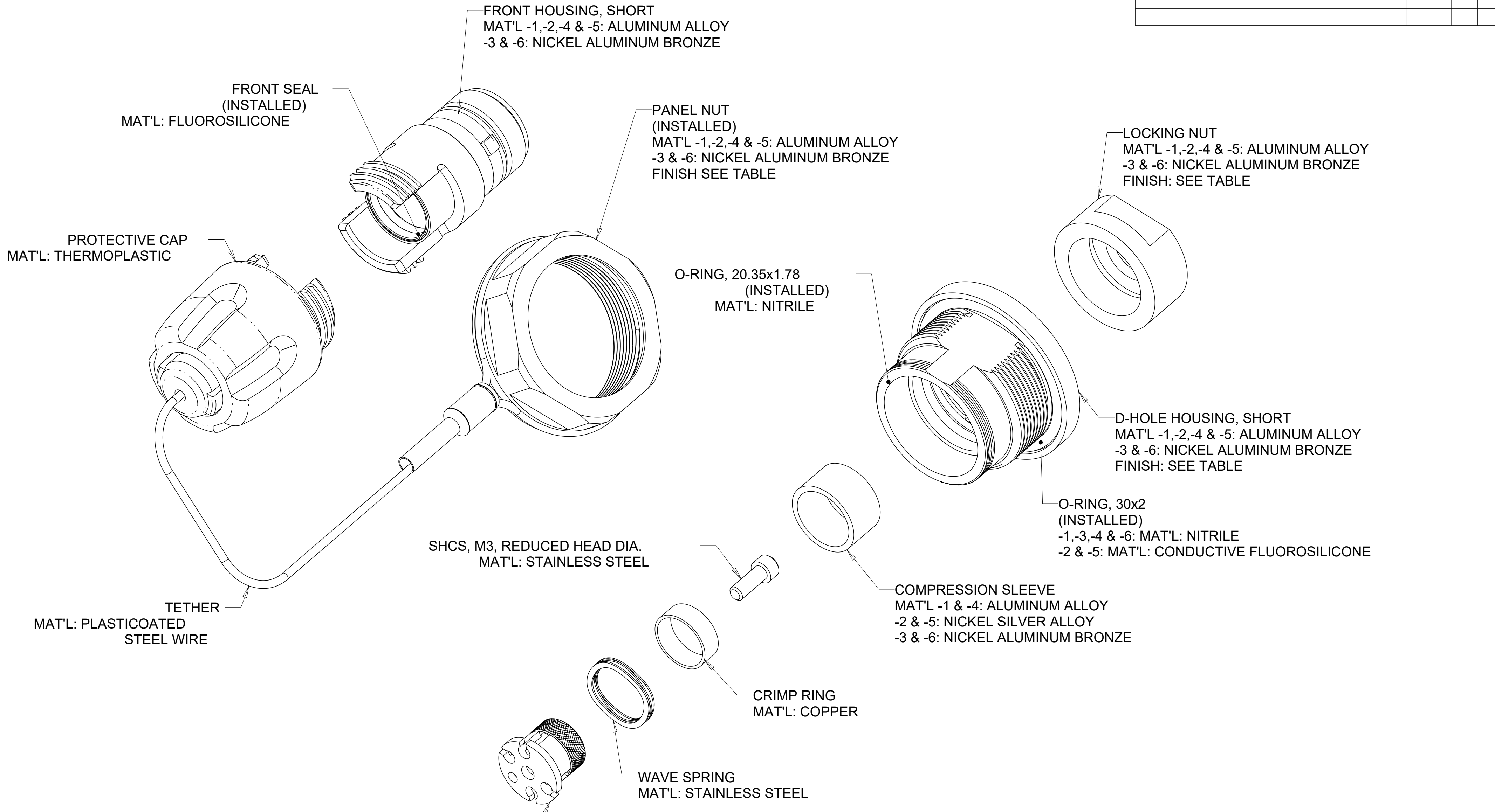

THIS DRAWING IS A CONTROLLED DOCUMENT.		DWN K.GLATFELTER 08JUN2006	TE Connectivity															
DIMENSIONS: mm		CHK D. WERTMAN 14JUN2006																
TOLERANCES UNLESS OTHERWISE SPECIFIED:		APVD D. WERTMAN 14JUN2006	NAME CONNECTOR SHELL KIT, PRO BEAM JR. D-HOLE LP BULKHEAD, 2.1mm															
<table border="1"> <tr><td>0 PLC</td><td>±</td></tr> <tr><td>1 PLC</td><td>±</td></tr> <tr><td>2 PLC</td><td>±</td></tr> <tr><td>3 PLC</td><td>±</td></tr> <tr><td>4 PLC</td><td>±</td></tr> <tr><td>ANGLES</td><td>±</td></tr> <tr><td>FINISH</td><td>±</td></tr> </table>		0 PLC	±	1 PLC	±	2 PLC	±	3 PLC	±	4 PLC	±	ANGLES	±	FINISH	±	PRODUCT SPEC -	RESTRICTED TO -	
0 PLC	±																	
1 PLC	±																	
2 PLC	±																	
3 PLC	±																	
4 PLC	±																	
ANGLES	±																	
FINISH	±																	
MATERIAL AS LISTED	SEE TABLE SHEET 1	APPLICATION SPEC -	SIZE A2	CAGE CODE 00779														
-		WEIGHT -	DRAWING NO 6828413	SCALE 2:1														
CUSTOMER DRAWING			SHEET 2	OF 2														
			REV D1															