

ISO121x Isolated 24-V to 60-V Digital Input Receivers for Digital Input Modules

1 Features

- Compliant to IEC 61131-2; Type 1, 2, 3 characteristics for 24-V isolated digital inputs
- Supports 9-V to 300-V DC and AC digital input designs using external resistors
- Accurate Current Limit for Low-Power Dissipation:
 - 2.2 mA to 2.47 mA for Type 3
 - Adjustable up to 6.5 mA
- Eliminates the need for field-side power supply
- High input-voltage range with reverse polarity protection: ± 60 V
- Wire-break detection (refer to [TIDA-01509](#))
- Configurable as sourcing or sinking input
- High data rates: up to 4 Mbps
- Enable pin to multiplex output signals
- High transient immunity: ± 70 -kV/ μ s CMTI
- Wide supply range (V_{CC1}): 2.25 V to 5.5 V
- Ambient temperature range: -40°C to $+125^{\circ}\text{C}$
- Compact package options:
 - Single-channel ISO1211, SOIC-8
 - Dual-channel ISO1212, SSOP-16
- [Safety-Related Certifications](#):
 - Basic insulation per DIN VDE V 0884-11
 - UL 1577 recognition, 2500- V_{RMS} insulation
 - IEC 60950-1, IEC 62368-1, IEC 61010-1 and GB 4943.1-2011 certifications

2 Applications

- Programmable Logic Controller (PLC)
 - Digital Input Modules
 - Mixed I/O Modules
- Motor Drive I/O and Position Feedback
- CNC Control
- Data Acquisition
- Binary Input Modules

3 Description

The ISO1211 and ISO1212 devices are isolated 24-V to 60-V digital input receivers, compliant to IEC 61131-2 Type 1, 2, and 3 characteristics. These devices enable 9-V to 300-V DC and AC digital input modules in programmable logic controllers (PLCs), motor-control, grid infrastructure, and other industrial applications. Unlike traditional optocoupler solutions with discrete, imprecise current limiting circuitry, the ISO121x devices provide a simple, low-power solution with an accurate current limit to enable the design of compact and high-density I/O modules. These devices do not require field-side power supply and are configurable as sourcing or sinking inputs.

The ISO121x devices operate over the supply range of 2.25 V to 5.5 V, supporting 2.5-V, 3.3-V, and 5-V controllers. A ± 60 -V input tolerance with reverse polarity protection helps ensure the input pins are protected in case of faults with negligible reverse current. These devices support up to 4-Mbps data rates passing a minimum pulse width of 150 ns for high-speed operation. The ISO1211 device is ideal for designs that require channel-to-channel isolation and the ISO1212 device is ideal for multichannel space-constrained designs.

The ISO121x devices reduce component count, simplify system design, improve performance, and reduce board temperatures compared to traditional solutions. For details, refer to the [How To Simplify Isolated 24-V PLC Digital Input Module Designs TI TechNote](#), [How To Improve Speed and Reliability of Isolated Digital Inputs in Motor Drives TI TechNote](#), and [How to Design Isolated Comparators for \$\pm 48\$ V, 110V and 240V DC and AC Detection TI TechNote](#).

Device Information⁽¹⁾

PART NUMBER	PACKAGE	BODY SIZE (NOM)
ISO1211	SOIC (8)	4.90 mm \times 3.91 mm
ISO1212	SSOP (16)	4.90 mm \times 3.90 mm

(1) For all available packages, see the orderable addendum at the end of the data sheet.

Application Diagram

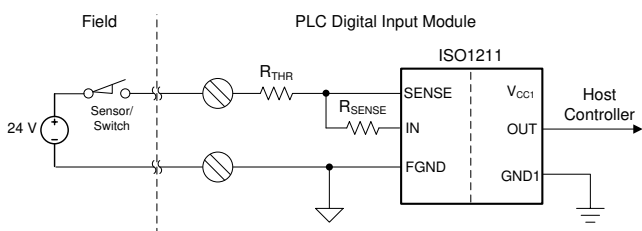

Copyright © 2017, Texas Instruments Incorporated

ISO121x Devices Reduce Board Temperatures vs Traditional Solutions

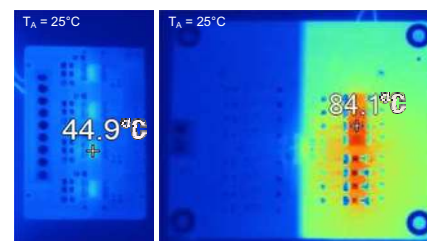

a) 8-Ch With ISO1212 b) 8-Ch Traditional Solution Without Current Limit



Table of Contents

1 Features	1	8.1 Overview	18
2 Applications	1	8.2 Functional Block Diagram	18
3 Description	1	8.3 Feature Description	18
4 Revision History	2	8.4 Device Functional Modes	19
5 Pin Configuration and Functions	4	9 Application and Implementation	20
6 Specifications	6	9.1 Application Information	20
6.1 Absolute Maximum Ratings	6	9.2 Typical Application	20
6.2 ESD Ratings	6	10 Power Supply Recommendations	31
6.3 Recommended Operating Conditions	6	11 Layout	32
6.4 Thermal Information	7	11.1 Layout Guidelines	32
6.5 Power Ratings	7	11.2 Layout Example	32
6.6 Insulation Specifications	8	12 Device and Documentation Support	34
6.7 Safety-Related Certifications	9	12.1 Device Support	34
6.8 Safety Limiting Values	10	12.2 Documentation Support	34
6.9 Electrical Characteristics—DC Specification	11	12.3 Related Links	34
6.10 Switching Characteristics—AC Specification	12	12.4 Receiving Notification of Documentation Updates	34
6.11 Insulation Characteristics Curves	13	12.5 Community Resource	34
6.12 Typical Characteristics	14	12.6 Trademarks	34
7 Parameter Measurement Information	15	12.7 Electrostatic Discharge Caution	35
7.1 Test Circuits	15	12.8 Glossary	35
8 Detailed Description	18	13 Mechanical, Packaging, and Orderable Information	35

4 Revision History

NOTE: Page numbers for previous revisions may differ from page numbers in the current version.

Changes from Revision E (August 2018) to Revision F	Page
• Changed VDE standard name From: DIN V VDE V 0884-10 To: DIN VDE V 0884-11 throughout the document	1
• Changed Features bullet From: "CSA, CQC, TUV Certificates Available" To: "IEC 60950-1, IEC 62368-1, IEC 61010-1 and GB 4943.1-2011 certifications"	1
• Updated Applications list	1
• Changed ISO1211 'SUB' pin description text From: "Leave this pin unconnected on the board" To: "For good thermal performance, it is recommended to connect this pin to a small 2 mm x 2 mm floating plane on the board. Do not connect this floating plane to FGND or any other signal or plane." in Pin Functions table	4
• Changed ISO1212 'SUB1' and 'SUB2' pins description text From: "Leave this pin unconnected on the board" To: "For good thermal performance, it is recommended to connect this pin to a small 2 mm x 2 mm floating plane on the board. Do not connect this floating plane to FGND1, FGND2, SUBx or any other signal or plane." in Pin Functions table	5
• Updated certification information in Safety-Related Certifications table	9

Changes from Revision D (March 2018) to Revision E	Page
• Changed V_{IH} and V_{IH} to V_{IL} and V_{IH} in the R_{THR} resistor description in the <i>Setting Current Limit and Voltage Thresholds</i> section	22

Changes from Revision C (February 2018) to Revision D	Page
• Updated the <i>Features</i> and <i>Applications</i> sections. Added a new TI TechNote reference to the <i>Description</i> and <i>Related Documentation</i> section	1
• Changed the unit for CPG from μm to mm in the <i>Insulation Specifications</i> table	8
• Changed the <i>Functional Block Diagram</i>	18

• Changed V_{IL} from min to typ in the V_{IL} equation	23
• Added the <i>Designing for Input Voltages Greater Than 60 V</i> section	25
• Added the bidirectional implementation example to the <i>Sourcing and Sinking Inputs</i> section	31

Changes from Revision B (September 2017) to Revision C	Page
---	-------------

• Added wire-break detection to the <i>Features</i> section	1
• Added the enable pin to multiplex output signals to the <i>Features</i> section	1
• Changed $R_{THR} = 5\text{ k}\Omega$ to $4\text{ k}\Omega$ in the <i>High-Level Voltage Transition Threshold vs Ambient Temperature</i> graph	14
• Changed the Type 1 R_{TH} value from $3\text{ k}\Omega$ to $2.5\text{ k}\Omega$ in the <i>Surge, IEC ESD and EFT</i> table	26

Changes from Revision A (September 2017) to Revision B	Page
---	-------------

• Changed the status from <i>Advance Information</i> to <i>Production Data</i>	1
--	---

5 Pin Configuration and Functions

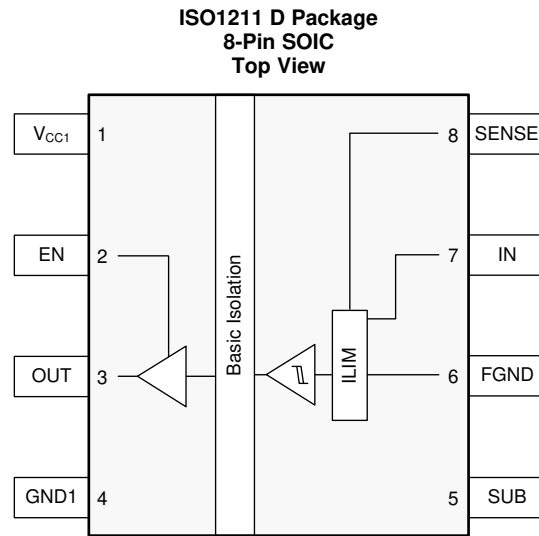

Pin Functions

PIN		I/O	DESCRIPTION
NO.	NAME		
1	V _{CC1}	—	Power supply, side 1
2	EN	I	Output enable. The output pin on side 1 is enabled when the EN pin is high or open. The output pin on side 1 is in the high-impedance state when the EN pin is low. In noisy applications, tie the EN pin to V _{CC1} .
3	OUT	O	Channel output
4	GND1	—	Ground connection for V _{CC1}
5	SUB	—	Internal connection to input chip substrate. For good thermal performance, it is recommended to connect this pin to a small 2 mm x 2 mm floating plane on the board. Do not connect this floating plane to FGND or any other signal or plane.
6	FGND	—	Field-side ground
7	IN	I	Field-side current input
8	SENSE	I	Field-side voltage sense

**ISO1212 DBQ Package
16-Pin SSOP
Top View**

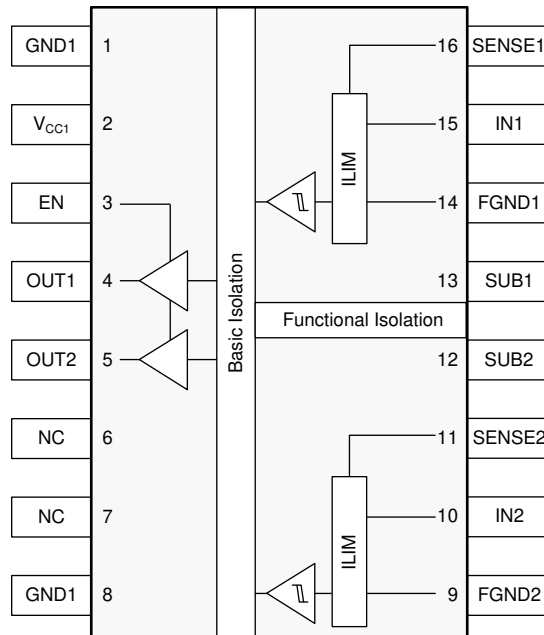

Pin Functions

PIN		I/O	Description
NO.	NAME		
1	GND1	—	Ground connection for V_{CC1}
2	V_{CC1}	—	Power supply, side 1
3	EN	I	Output enable. The output pins on side 1 are enabled when the EN pin is high or open. The output pins on side 1 are in the high-impedance state when the EN pin is low. In noisy applications, tie the EN pin to V_{CC1} .
4	OUT1	O	Channel 1 output
5	OUT2	O	Channel 2 output
6	NC	—	Not connected
7			
8	GND1	—	Ground connection for V_{CC1}
9	FGND2	—	Field-side ground, channel 2
10	IN2	I	Field-side current input, channel 2
11	SENSE2	I	Field-side voltage sense, channel 2
12	SUB2	—	Internal connection to input chip 2 substrate. For good thermal performance, it is recommended to connect this pin to a small 2 mm x 2 mm floating plane on the board. Do not connect this floating plane to FGND1, FGND2, SUB1 or any other signal or plane.
13	SUB1	—	Internal connection to input chip 1 substrate. For good thermal performance, it is recommended to connect this pin to a small 2 mm x 2 mm floating plane on the board. Do not connect this floating plane to FGND1, FGND2, SUB2 or any other signal or plane.
14	FGND1	—	Field-side ground, channel 1
15	IN1	I	Field-side current input, channel 1
16	SENSE1	I	Field-side voltage sense, channel 1

6 Specifications

6.1 Absolute Maximum Ratings

over operating free-air temperature range (unless otherwise noted)⁽¹⁾

		MIN	MAX	UNIT
V_{CC1}	Supply voltage, control side	-0.5	6	V
V_{OUTx}, V_{EN}	Voltage on OUTx pins and EN pin	-0.5	$V_{CC1} + 0.5^{(2)}$	V
I_O	Output current on OUTx pins	-15	15	mA
V_{INx}, V_{SENSEx}	Voltage on IN and SENSE pins	-60	60	V
$V_{(ISO, FUNC)}$	Functional isolation between channels in ISO1212 on the field side	-60	60	V
T_J	Junction temperature	-40	150	°C
T_{stg}	Storage temperature	-65	150	°C

- (1) Stresses beyond those listed under *Absolute Maximum Ratings* may cause permanent damage to the device. These are stress ratings only, which do not imply functional operation of the device at these or any other conditions beyond those indicated under *Recommended Operating Conditions*. Exposure to absolute-maximum-rated conditions for extended periods may affect device reliability.
- (2) Maximum voltage must not exceed 6 V.

6.2 ESD Ratings

			VALUE	UNIT
$V_{(ESD)}$	Electrostatic discharge	Human body model (HBM), per ANSI/ESDA/JEDEC JS-001 ⁽¹⁾	±2000	V
		Charged device model (CDM), per JEDEC specification JESD22-C101 ⁽²⁾	±1000	

- (1) JEDEC document JEP155 states that 500-V HBM allows safe manufacturing with a standard ESD control process.
- (2) JEDEC document JEP157 states that 250-V CDM allows safe manufacturing with a standard ESD control process.

6.3 Recommended Operating Conditions

			MIN	MAX	UNIT
V_{CC1}	Supply voltage input side		2.25	5.5	V
V_{INx}, V_{SENSEx}	Voltage on INx and SENSEx pins ⁽¹⁾		-60	60	V
I_{OH}	High-level output current from OUTx pin	$V_{CC1} = 5\text{ V}$	-4		mA
		$V_{CC1} = 3.3\text{ V}$	-3		
		$V_{CC1} = 2.5\text{ V}$	-2		
I_{OL}	Low-level output current into OUTx pin	$V_{CC1} = 5\text{ V}$		4	mA
		$V_{CC1} = 3.3\text{ V}$		3	
		$V_{CC1} = 2.5\text{ V}$		2	
t_{UI}	Minimum pulse width at SENSEx pins		150		ns
T_A	Ambient temperature		-40	125	°C

- (1) See the [Thermal Considerations](#) section.

6.4 Thermal Information

THERMAL METRIC ⁽¹⁾		ISO1211	ISO1212	UNIT
		D (SOIC)	DBQ (SSOP)	
		8 PINS	16 PINS	
R _{θJA}	Junction-to-ambient thermal resistance	146.1	116.9	°C/W
R _{θJC(top)}	Junction-to-case (top) thermal resistance	63.1	56.5	°C/W
R _{θJB}	Junction-to-board thermal resistance	80	64.7	°C/W
Ψ _{JT}	Junction-to-top characterization parameter	9.6	27.9	°C/W
Ψ _{JB}	Junction-to-board characterization parameter	79	64.1	°C/W
R _{θJC(bot)}	Junction-to-case (bottom) thermal resistance	—	—	°C/W

(1) For more information about traditional and new thermal metrics, see the [Semiconductor and IC Package Thermal Metrics application report](#).

6.5 Power Ratings

PARAMETER		TEST CONDITIONS	MIN	TYP	MAX	UNIT
ISO1211						
P _D	Maximum power dissipation, both sides	V _{SENSE} = 60 V, V _{CC1} = 5.5 V, R _{SENSE} = 200 Ω, R _{THR} = 0 Ω, T _J = 150°C			450	mW
P _{D1}	Maximum power dissipation, output side (side 1)	V _{CC1} = 5.5 V, C _L = 15 pF, Input 2-MHz 50% duty-cycle square wave at SENSE pin, T _J = 150°C			20	mW
P _{D2}	Maximum power dissipation, field input side	V _{SENSE} = 60 V, V _{CC1} = 5.5 V, R _{SENSE} = 200 Ω, R _{THR} = 0 Ω, T _J = 150°C			430	mW
ISO1212						
P _D	Maximum power dissipation, both sides	V _{SENSEX} = 60 V, V _{CC1} = 5.5 V, R _{SENSE} = 200 Ω, R _{THR} = 0 Ω, T _J = 150°C			900	mW
P _{D1}	Maximum power dissipation, output side (side 1)	V _{CC1} = 5.5 V, C _L = 15 pF, Input 2-MHz 50% duty-cycle square wave at SENSEx pins, T _J = 150°C			40	mW
P _{D2}	Maximum power dissipation, field input side	V _{SENSEX} = 60 V, V _{CC1} = 5.5 V, R _{SENSE} = 200 Ω, R _{THR} = 0 Ω, T _J = 150°C			860	mW

6.6 Insulation Specifications

PARAMETER		TEST CONDITIONS	SPECIFICATION		UNIT
			D-8	DBQ-16	
CLR	External clearance ⁽¹⁾	Shortest terminal-to-terminal distance through air	4	3.7	mm
CPG	External Creepage ⁽¹⁾	Shortest terminal-to-terminal distance across the package surface	4	3.7	mm
DTI	Distance through the insulation	Minimum internal gap (internal clearance)	10.5	10.5	µm
CTI	Comparative tracking index	DIN EN 60112 (VDE 0303-11); IEC 60112	> 600	> 600	V
	Material Group	According to IEC 60664-1	I	I	
	Overvoltage category	Rated mains voltage ≤ 150 V _{RMS}	I-IV	I-IV	
		Rated mains voltage ≤ 300 V _{RMS}	I-III	I-III	
DIN VDE V 0884-11:2017-01⁽²⁾					
V _{IORM}	Maximum repetitive peak isolation voltage	AC voltage (bipolar)	566	566	V _{PK}
V _{IOWM}	Maximum working isolation voltage	AC voltage (sine wave); time-dependent dielectric breakdown (TDDb) test	400	400	V _{RMS}
		DC voltage	566	566	V _{DC}
V _{IOTM}	Maximum transient isolation voltage	V _{TEST} = V _{IOTM} , t = 60 s (qualification), V _{TEST} = V _{IOTM} , t = 1 s (100% production)	3600	3600	V _{PK}
V _{IOSM}	Maximum surge isolation voltage ⁽³⁾	Test method per IEC 60065-1, 1.2/50 µs waveform, V _{TEST} = 1.3 × V _{IOSM} = 5200 V _{PK} (qualification)	4000	4000	V _{PK}
q _{pd}	Apparent charge ⁽⁴⁾	Method a: After I/O safety test subgroup 2/3, V _{ini} = V _{IOTM} , t _{ini} = 60 s; V _{pd(m)} = 1.2 × V _{IORM} = 680 V _{PK} , t _m = 10 s	< 5	< 5	pC
		Method a: After environmental tests subgroup 1, V _{ini} = V _{IOTM} , t _{ini} = 60 s; V _{pd(m)} = 1.3 × V _{IORM} = 736 V _{PK} , t _m = 10 s	< 5	< 5	
		Method b1: At routine test (100% production) and preconditioning (type test), V _{ini} = V _{IOTM} , t _{ini} = 1 s; V _{pd(m)} = 1.5 × V _{IORM} = 849 V _{PK} , t _m = 10 s	< 5	< 5	
C _{IO}	Barrier capacitance, input to output ⁽⁵⁾	V _{IO} = 0.4 × sin(2 πft), f = 1 MHz	440	560	fF
R _{IO}	Insulation resistance, input to output ⁽⁵⁾	V _{IO} = 500 V, T _A = 25°C	> 10 ¹²	> 10 ¹²	Ω
		V _{IO} = 500 V, 100°C ≤ T _A ≤ 125 °C	> 10 ¹¹	> 10 ¹¹	
		V _{IO} = 500 V at T _S = 150 °C	> 10 ⁹	> 10 ⁹	
	Pollution degree		2	2	
	Climatic category		40/125/21	40/125/21	
UL 1577					
V _{ISO}	Withstand isolation voltage	V _{TEST} = V _{ISO} = 2500 V _{RMS} , t = 60 s (qualification); V _{TEST} = 1.2 × V _{ISO} = 3000 V _{RMS} , t = 1 s (100% production)	2500	2500	V _{RMS}

- (1) Creepage and clearance requirements should be applied according to the specific equipment isolation standards of an application. Care should be taken to maintain the creepage and clearance distance of a board design to ensure that the mounting pads of the isolator on the printed-circuit board do not reduce this distance. Creepage and clearance on a printed-circuit board become equal in certain cases. Techniques such as inserting grooves and/or ribs on a printed circuit board are used to help increase these specifications.
- (2) This coupler is suitable for *basic electrical insulation* only within the maximum operating ratings. Compliance with the safety ratings shall be ensured by means of suitable protective circuits.
- (3) Testing is carried out in air or oil to determine the intrinsic surge immunity of the isolation barrier.
- (4) Apparent charge is electrical discharge caused by a partial discharge (pd).
- (5) All pins on each side of the barrier tied together creating a two-terminal device

6.7 Safety-Related Certifications

VDE	CSA	UL	CQC	TUV
Certified according to DIN VDE V 0884-11:2017-01 and DIN EN 61010-1 (VDE 0411-1):2011-07	Certified according to IEC 60950-1 and IEC 62368-1	Recognized under UL 1577 Component Recognition Program	Certified according to GB4943.1-2011	Certified according to EN 61010-1:2010/A1:2019, EN 60950-1:2006/A2:2013 and EN 62368-1:2014
Basic Insulation, Maximum Transient Isolation Voltage, 3600 V _{PK} , Maximum Repetitive Peak Isolation Voltage, 566 V _{PK} , Maximum Surge Isolation Voltage, 4000 V _{PK}	370 V _{RMS} (ISO1212) and 400 V _{RMS} (ISO1211) Basic Insulation working voltage per CSA 60950-1-07+A1 + A2 and IEC 60950-1 2nd Ed. + A1 + A2 300 V _{RMS} Basic Insulation working voltage per CSA 62368-1-14 and IEC 62368-1 2nd Ed.	Single protection, 2500 V _{RMS}	Basic Insulation, Altitude ≤ 5000m, Tropical Climate, 400 V _{RMS} maximum working voltage	Basic insulation per EN 61010-1:2010/A1:2019 up to working voltage of 300 V _{RMS} , Basic insulation per EN 60950-1:2006/A2:2013 and EN 62368-1:2014 up to working voltage of 370 V _{RMS} (ISO1212) and 400 V _{RMS} (ISO1211)
Certificate number: 40047657	Master contract number: 220991	File number: E181974	Certificate number: CQC15001121656(ISO1211) CQC18001199097(ISO1212)	Client ID number: 77311

6.8 Safety Limiting Values

Safety limiting⁽¹⁾ intends to minimize potential damage to the isolation barrier upon failure of input or output circuitry. A failure of the I/O can allow low resistance to ground or the supply and, without current limiting, dissipate sufficient power to overheat the die and damage the isolation barrier, potentially leading to secondary system failures.

PARAMETER	TEST CONDITIONS	MIN	TYP	MAX	UNIT
ISO1211					
I _S	Safety input, output, or supply current - side 1	R _{θJA} = 146.1°C/W, V _I = 2.75 V, T _J = 150°C, T _A = 25°C, see Figure 1		310	mA
		R _{θJA} = 146.1°C/W, V _I = 3.6 V, T _J = 150°C, T _A = 25°C, see Figure 1		237	
		R _{θJA} = 146.1°C/W, V _I = 5.5 V, T _J = 150°C, T _A = 25°C, see Figure 1		155	
I _S	Safety input current - field side	R _{θJA} = 146.1°C/W, V _I = 24 V, T _J = 150°C, T _A = 25°C, see Figure 1		35	mA
		R _{θJA} = 146.1°C/W, V _I = 36 V, T _J = 150°C, T _A = 25°C, see Figure 1		23	
		R _{θJA} = 146.1°C/W, V _I = 60 V, T _J = 150°C, T _A = 25°C, see Figure 1		14	
P _S	Safety input, output, or total power	R _{θJA} = 146.1°C/W, T _J = 150°C, T _A = 25°C, see Figure 2		855	mW
T _S	Maximum safety temperature			150	°C
ISO1212					
I _S	Safety input, output, or supply current - side 1	R _{θJA} = 116.9°C/W, V _I = 2.75 V, T _J = 150°C, T _A = 25°C, see Figure 3		389	mA
		R _{θJA} = 116.9°C/W, V _I = 3.6 V, T _J = 150°C, T _A = 25°C, see Figure 3		297	
		R _{θJA} = 116.9°C/W, V _I = 5.5 V, T _J = 150°C, T _A = 25°C, see Figure 3		194	
I _S	Safety input current - field side	R _{θJA} = 116.9°C/W, V _I = 24 V, T _J = 150°C, T _A = 25°C, see Figure 3		44	mA
		R _{θJA} = 116.9°C/W, V _I = 36 V, T _J = 150°C, T _A = 25°C, see Figure 3		29	
		R _{θJA} = 116.9°C/W, V _I = 60 V, T _J = 150°C, T _A = 25°C, see Figure 3		17	
P _S	Safety input, output, or total power	R _{θJA} = 116.9°C/W, T _J = 150°C, T _A = 25°C, see Figure 4		1070	mW
T _S	Maximum safety temperature			150	°C

- (1) The safety-limiting constraint is the maximum junction temperature specified in the data sheet. The power dissipation and junction-to-air thermal impedance of the device installed in the application hardware determines the junction temperature. The assumed junction-to-air thermal resistance in the [Thermal Information](#) table is that of a device installed on a high-K test board for leaded surface-mount packages. The power is the recommended maximum input voltage times the current. The junction temperature is then the ambient temperature plus the power times the junction-to-air thermal resistance.

6.9 Electrical Characteristics—DC Specification

(Over recommended operating conditions unless otherwise noted).

PARAMETER		TEST CONDITIONS	MIN	TYP	MAX	UNIT
V_{CC1} VOLTAGE SUPPLY						
V _{IT+} (UVLO1)	Positive-going UVLO threshold voltage (V _{CC1})				2.25	V
V _{IT-} (UVLO1)	Negative-going UVLO threshold (V _{CC1})		1.7			V
V _{HYS} (UVLO1)	UVLO threshold hysteresis (V _{CC1})			0.2		V
I _{CC1}	V _{CC1} supply quiescent current	ISO1211	EN = V _{CC1}	0.6	1	mA
		ISO1212		1.2	1.9	
LOGIC I/O						
V _{IT+} (EN)	Positive-going input logic threshold voltage for EN pin				0.7 × V _{CC1}	V
V _{IT-} (EN)	Negative-going input logic threshold voltage for EN pin		0.3 × V _{CC1}			V
V _{HYS} (EN)	Input hysteresis voltage for EN pin			0.1 × V _{CC1}		V
I _{IH}	Low-level input leakage at EN pin	EN = GND1	-10			μA
V _{OH}	High-level output voltage on OUTx	V _{CC1} = 4.5 V; I _{OH} = -4 mA V _{CC1} = 3 V; I _{OH} = -3 mA V _{CC1} = 2.25 V; I _{OH} = -2 mA, see Figure 10			V _{CC1} - 0.4	V
V _{OL}	Low-level output voltage on OUTx	V _{CC1} = 4.5 V; I _{OH} = 4 mA V _{CC1} = 3 V; I _{OH} = 3 mA V _{CC1} = 2.25 V; I _{OH} = 2 mA, see Figure 10			0.4	V
CURRENT LIMIT						
I _{I(INx+SENSEx)} , TYP	Typical sum of current drawn from IN and SENSE pins across temperature	R _{THR} = 0 Ω, R _{SENSE} = 562 Ω, V _{SENSE} = 24 V, -40°C < T _A < 125°C, see Figure 11	2.2		2.47	mA
I _{I(INx+SENSEx)}	Sum of current drawn from IN and SENSE pins	R _{THR} = 0 Ω, R _{SENSE} = 562 Ω ± 1%; -60 V < V _{SENSE} < 0 V, see Figure 11		-0.1		μA
		R _{THR} = 0 Ω, R _{SENSE} = 562 Ω ± 1%; 5 V < V _{SENSE} < V _{IL} , see Figure 11	1.9		2.5	mA
		R _{THR} = 0 Ω, R _{SENSE} = 562 Ω ± 1%; V _{IL} < V _{SENSE} < 30 V, see Figure 11	2.05		2.75	
		R _{THR} = 0 Ω, R _{SENSE} = 562 Ω ± 1%; 30 V < V _{SENSE} < 36 V, see Figure 11	2.1		2.83	
		R _{THR} = 0 Ω, R _{SENSE} = 562 Ω ± 1%; 36 V < V _{SENSE} < 60 V ⁽¹⁾ , see Figure 11	2.1		3.1	
		R _{THR} = 0 Ω, R _{SENSE} = 200 Ω ± 1%; -60 V < V _{SENSE} < 0 V, see Figure 11		-0.1		μA
		R _{THR} = 0 Ω, R _{SENSE} = 200 Ω ± 1%; 5 V < V _{SENSE} < V _{IL} , see Figure 11	5.3		6.8	mA
		R _{THR} = 0 Ω, R _{SENSE} = 200 Ω ± 1%; V _{IL} < V _{SENSE} < 36 V ⁽¹⁾ , see Figure 11	5.5		7	
		R _{THR} = 0 Ω, R _{SENSE} = 200 Ω ± 1%; 36 V < V _{SENSE} < 60 V ⁽¹⁾ , see Figure 11	5.5		7.3	

(1) See the [Thermal Considerations](#) section.

Electrical Characteristics—DC Specification (continued)

(Over recommended operating conditions unless otherwise noted).

PARAMETER		TEST CONDITIONS	MIN	TYP	MAX	UNIT
VOLTAGE TRANSITION THRESHOLD ON FIELD SIDE						
V _{IL}	Low level threshold voltage at module input (including R _{THR}) for output low	R _{SENSE} = 562 Ω, R _{THR} = 0 Ω, see Figure 11	6.5	7		V
		R _{SENSE} = 562 Ω, R _{THR} = 1 kΩ, see Figure 11	8.7	9.2		
		R _{SENSE} = 562 Ω, R _{THR} = 4 kΩ, see Figure 11	15.2	15.8		
V _{IH}	High level threshold voltage at module input (including R _{THR}) for output high	R _{SENSE} = 562 Ω, R _{THR} = 0 Ω, see Figure 11		8.2	8.55	V
		R _{SENSE} = 562 Ω, R _{THR} = 1 kΩ, see Figure 11		10.4	10.95	
		R _{SENSE} = 562 Ω, R _{THR} = 4 kΩ, see Figure 11		17	18.25	
V _{HYS}	Threshold voltage hysteresis at module input	R _{SENSE} = 562 Ω, R _{THR} = 0 Ω, see Figure 11	1	1.2		V
		R _{SENSE} = 562 Ω, R _{THR} = 1 kΩ, see Figure 11	1	1.2		
		R _{SENSE} = 562 Ω, R _{THR} = 4 kΩ, see Figure 11	1	1.2		

6.10 Switching Characteristics—AC Specification

(Over recommended operating conditions unless otherwise noted).

PARAMETER		TEST CONDITIONS	MIN	TYP	MAX	UNIT
t _r , t _f	Output signal rise and fall time, OUTx pins	Input rise and fall times = 10 ns, see Figure 10		3		ns
t _{PLH}	Propagation delay time for low to high transition	Input rise and fall times = 10 ns, see Figure 10		110	140	ns
t _{PHL}	Propagation delay time for high to low transition	Input rise and fall times = 10 ns, see Figure 10		10	15	ns
t _{sk(p)}	Pulse skew t _{PHL} - t _{PLH}	Input rise and fall times = 10 ns, see Figure 10		102	130	ns
t _{UI}	Minimum pulse width	Input rise and fall times = 125 ns, see Figure 10	150			ns
t _{PHZ}	Disable propagation delay, high-to-high impedance output	See Figure 13		17	40	ns
t _{PLZ}	Disable propagation delay, low-to-high impedance output	See Figure 12		17	40	ns
t _{PZH}	Enable propagation delay, high impedance-to-high output	See Figure 13		3	8.5	μs
t _{PZL}	Enable propagation delay, high impedance-to-low output	See Figure 12		17	40	ns
CMTI	Common mode transient immunity	See Figure 14	25	70		kV/μs

6.11 Insulation Characteristics Curves

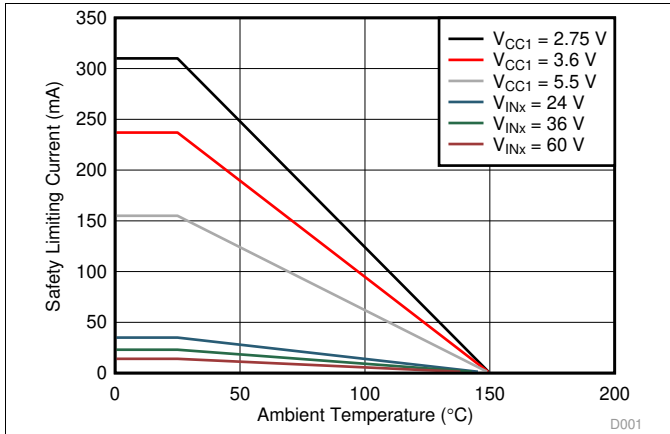

Figure 1. Thermal Derating Curve for Safety Limiting Current per VDE for D-8 Package

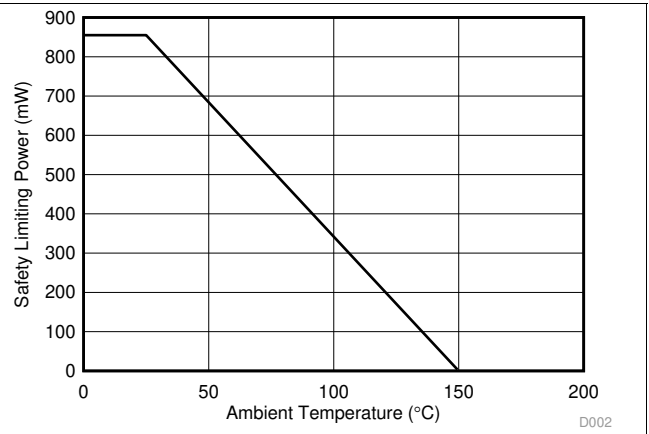

Figure 2. Thermal Derating Curve for Safety Limiting Power per VDE for D-8 Package

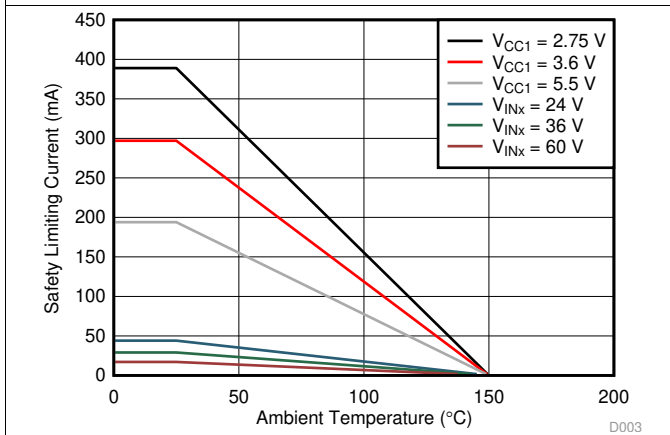

Figure 3. Thermal Derating Curve for Safety Limiting Current per VDE for DBQ-16 Package

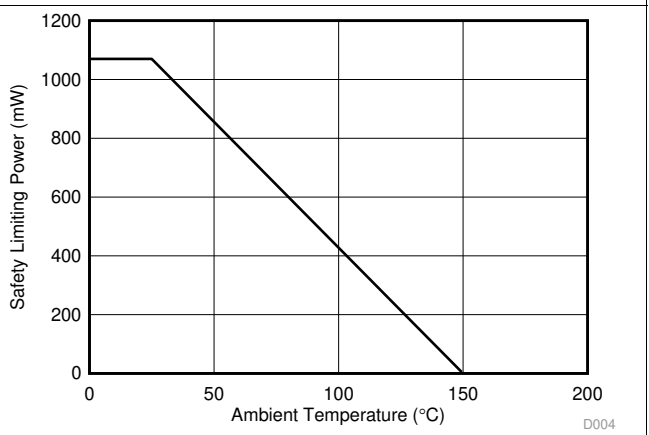
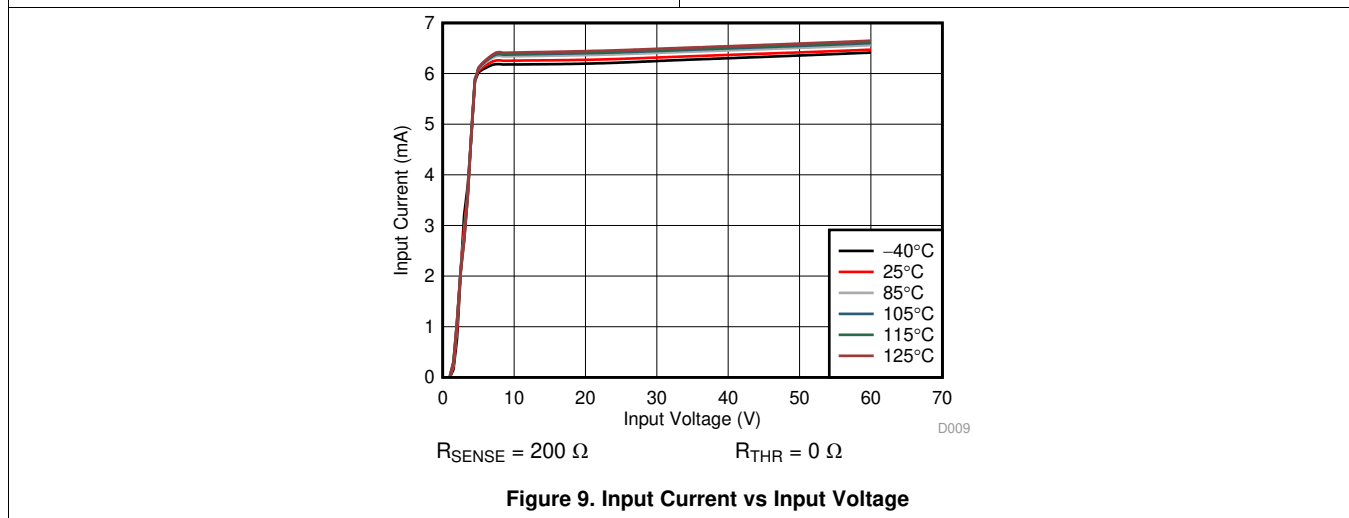
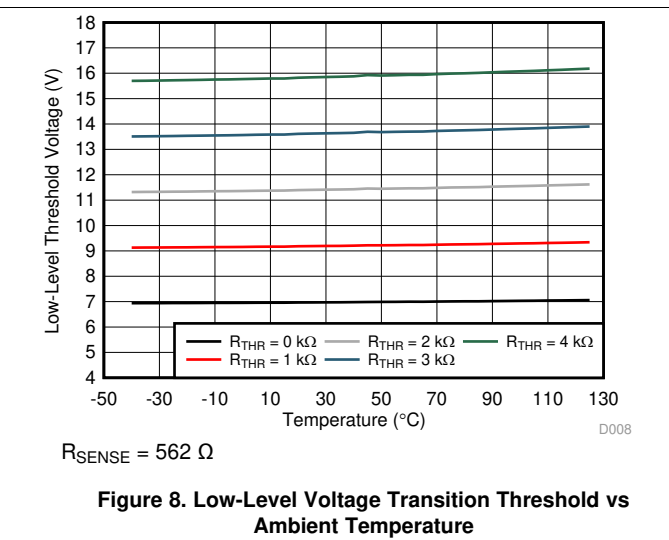
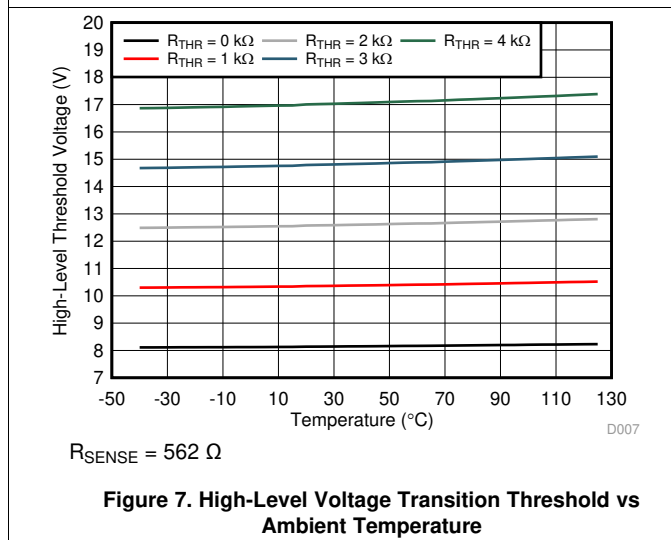
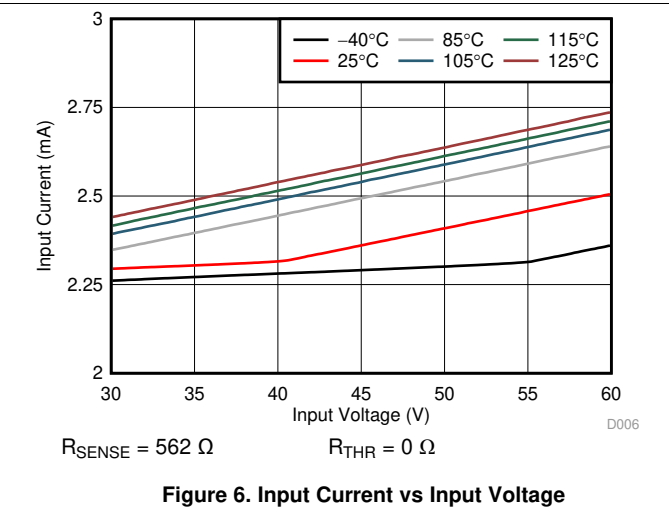
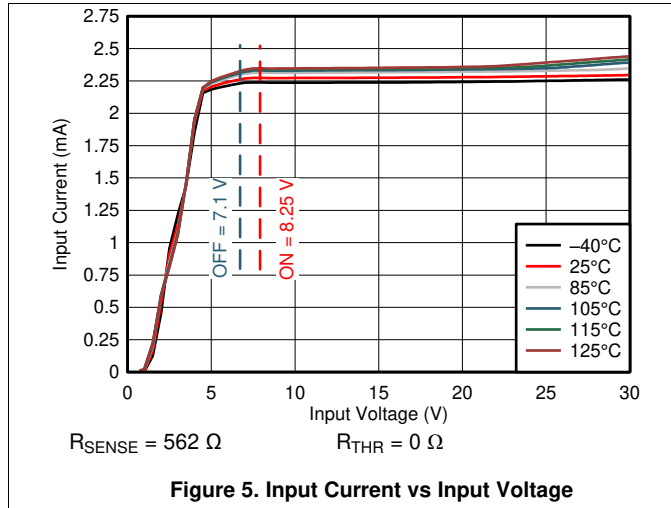

Figure 4. Thermal Derating Curve for Safety Limiting Power per VDE for DBQ-16 Package

6.12 Typical Characteristics



7 Parameter Measurement Information

7.1 Test Circuits

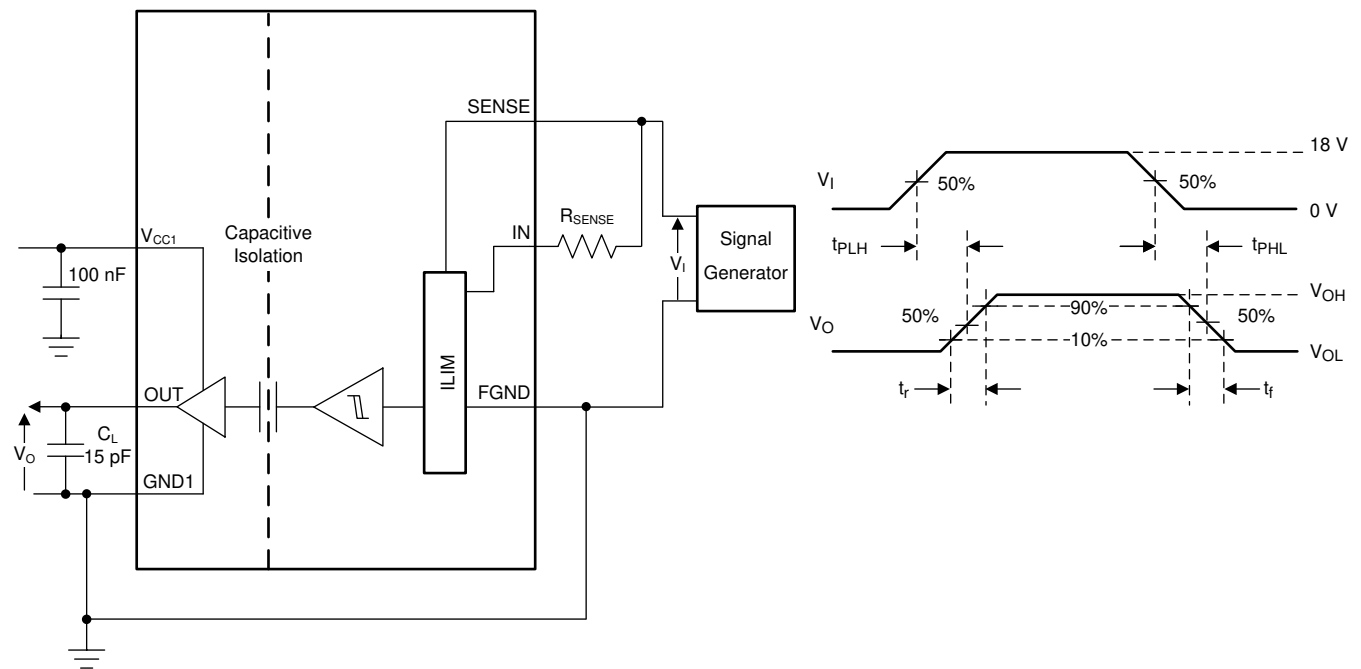

Figure 10. Switching Characteristics Test Circuit and Voltage Waveforms

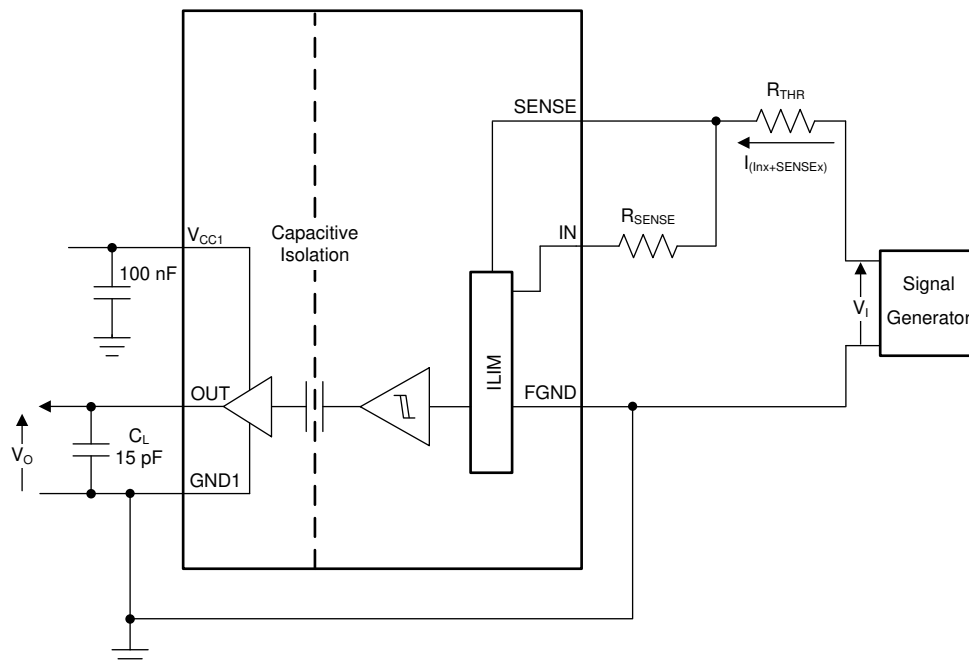

Figure 11. Input Current and Voltage Threshold Test Circuit

Test Circuits (continued)

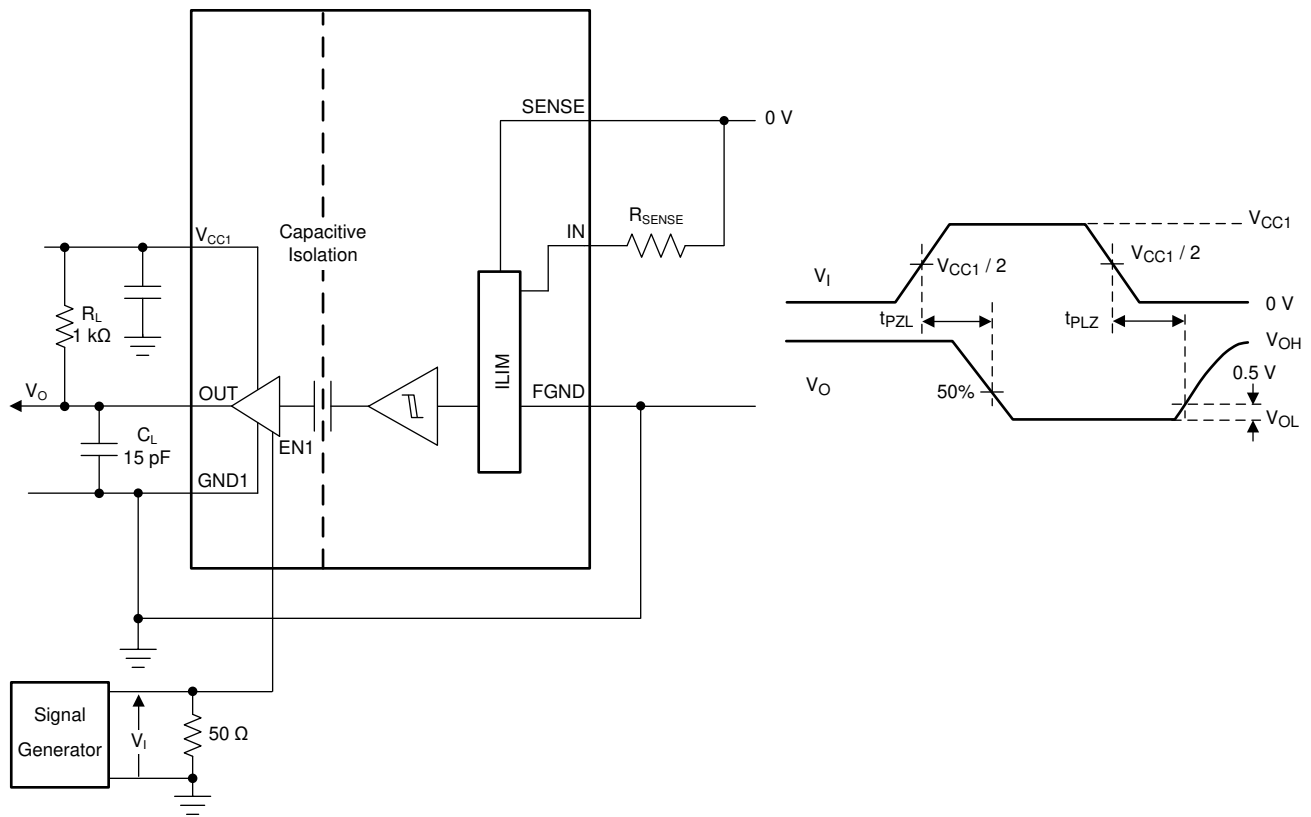

Figure 12. Enable and Disable Propagation Delay Time Test Circuit and Waveform—Logic Low State

Test Circuits (continued)

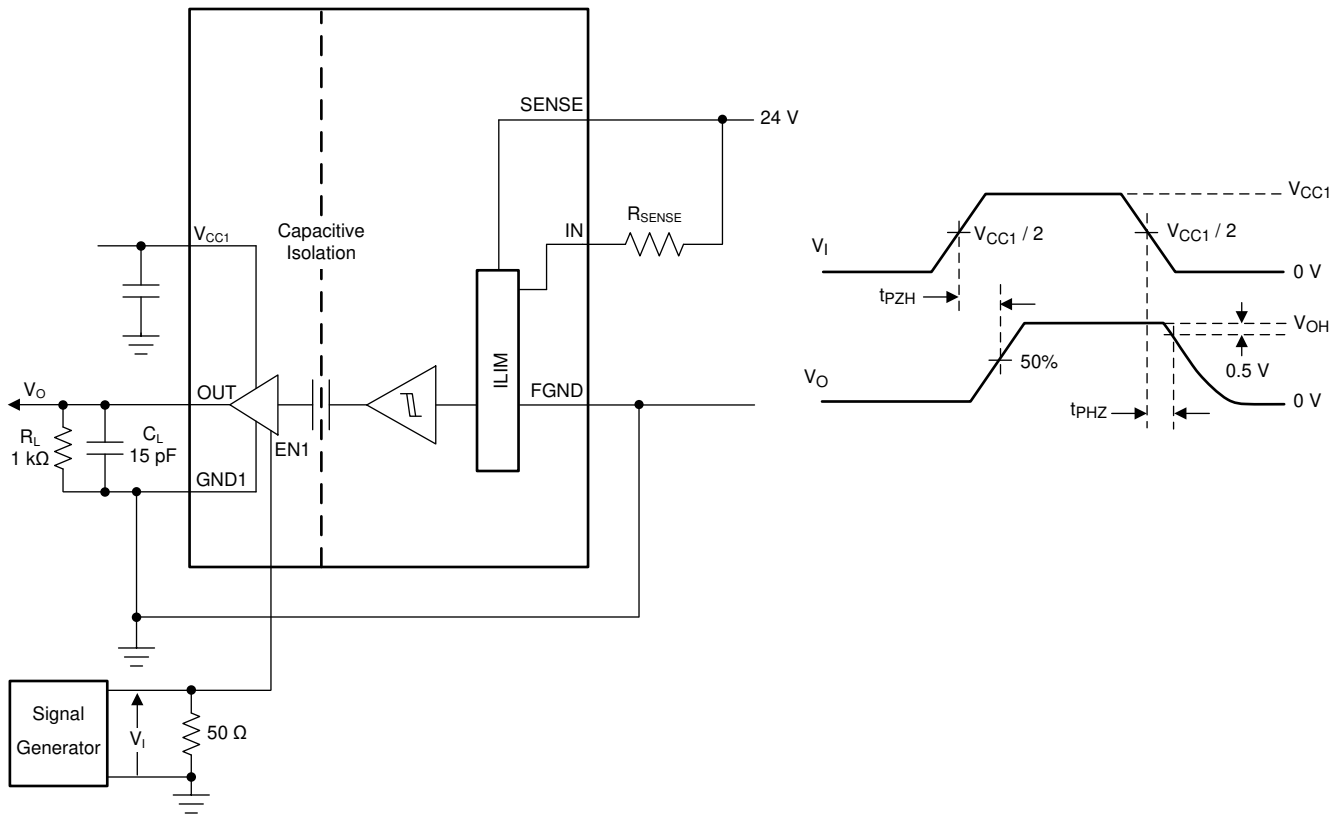
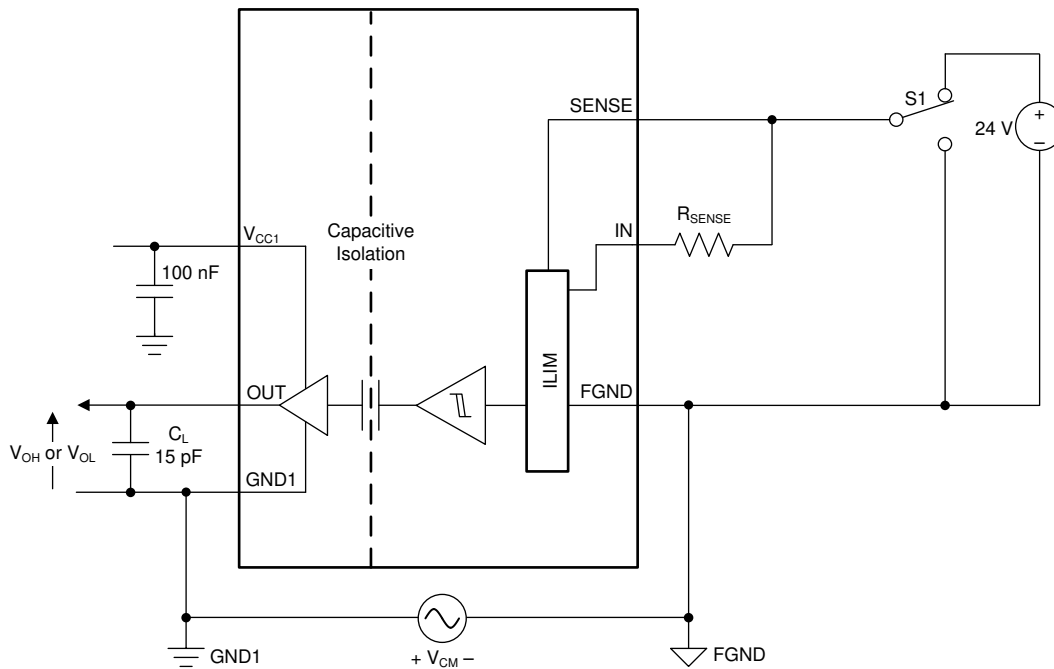

Figure 13. Enable and Disable Propagation Delay Time Test Circuit and Waveform—Logic High State



(1) Pass Criterion: The output must remain stable.

Figure 14. Common-Mode Transient Immunity Test Circuit

8 Detailed Description

8.1 Overview

The ISO1211 and ISO1212 devices are fully-integrated, isolated digital-input receivers with IEC 61131-2 Type 1, 2, and 3 characteristics. The devices receive 24-V to 60-V digital-input signals and provide isolated digital outputs. No field-side power supply is required. An external resistor, R_{SENSE} , on the input-signal path precisely sets the limit for the current drawn from the field input based on an internal feedback loop. The voltage transition thresholds are compliant with Type 1, 2, and 3 and can be increased further using an external resistor, R_{THR} . For more information on selecting the R_{SENSE} and R_{THR} resistor values, see the [Detailed Design Procedure](#) section. The ISO121x devices use an ON-OFF keying (OOK) modulation scheme to transmit the digital data across a silicon-dioxide based isolation barrier. The transmitter sends a high frequency carrier across the barrier to represent one digital state and sends no signal to represent the other digital state. The receiver demodulates the signal after advanced signal conditioning and produces the output through a buffer stage. The conceptual block diagram of the ISO121x device is shown in the [Functional Block Diagram](#) section.

8.2 Functional Block Diagram

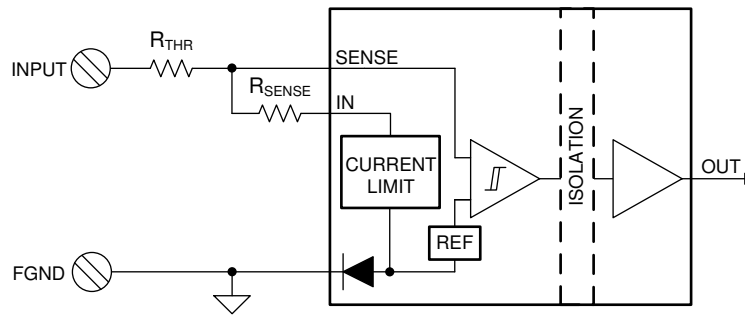

8.3 Feature Description

The ISO121x devices receive 24-V to 60-V digital input signals and provide isolated digital outputs. An external resistor, R_{SENSE} , connected between the INx and SENSEx pins, sets the limit for the current drawn from the field input. Internal voltage comparators connected to the SENSEx pins determine the input-voltage transition thresholds.

The output buffers on the control side are capable of providing enough current to drive status LEDs. The EN pin is used to enable the output buffers. A low state on the EN pin puts the output buffers in a high-impedance state.

The ISO121x devices are capable of operating up to 4 Mbps. Both devices support an isolation withstand voltage of 2500 V_{RMS} between side 1 and side 2. [Table 1](#) provides an overview of the device features.

Table 1. Device Features

PART NUMBER	CHANNELS	MAXIMUM DATA RATE	PACKAGE	RATED ISOLATION
ISO1211	1	4 Mbps	8-pin SOIC (D)	2500 V_{RMS} , 3600 V_{PK}
ISO1212	2	4 Mbps	16-pin SSOP (DBQ)	2500 V_{RMS} , 3600 V_{PK}

8.4 Device Functional Modes

Table 2 lists the functional modes for the ISO121x devices.

Table 2. Function Table⁽¹⁾

SIDE 1 SUPPLY V_{CC1}	INPUT (IN _x , SENSE _x)	OUTPUT ENABLE (EN)	OUTPUT (OUT _x)	COMMENTS
PU	H	H or Open	H	Channel output assumes the logic state of channel input.
	L	H or Open	L	
	Open	H or Open	L	When IN _x and SENSE _x are open, the output of the corresponding channel goes to Low.
	X	L	Z	A low value of output enable causes the outputs to be high impedance.
PD	X	X	Undetermined	When V_{CC1} is unpowered, a channel output is undetermined ⁽²⁾ . When V_{CC1} transitions from unpowered to powered up; a channel output assumes the logic state of the input.

(1) V_{CC1} = Side 1 power supply; PU = Powered up ($V_{CC1} \geq 2.25$ V); PD = Powered down ($V_{CC1} \leq 1.7$ V); X = Irrelevant; H = High level; L = Low level; Z = High impedance

(2) The outputs are in an undetermined state when 1.7 V < V_{CC1} < 2.25 V.

9 Application and Implementation

NOTE

Information in the following applications sections is not part of the TI component specification, and TI does not warrant its accuracy or completeness. TI's customers are responsible for determining suitability of components for their purposes. Customers should validate and test their design implementation to confirm system functionality.

9.1 Application Information

The ISO1211 and ISO1212 devices are fully-integrated, isolated digital-input receivers with IEC 61131-2 Type 1, 2, and 3 characteristics. These devices are suitable for high-channel density, digital-input modules for programmable logic controllers and motor control digital input modules. The devices receive 24-V to 60-V digital-input signals and provide isolated digital outputs. No field side power supply is required. An external resistor, R_{SENSE} , on the input signal path precisely sets the limit for the current drawn from the field input. This current limit helps minimize power dissipated in the system. The current limit can be set for Type 1, 2, or 3 operation. The voltage transition thresholds are compliant with Type 1, 2, and 3 and can be increased further using an external resistor, R_{THR} . For more information on selecting the R_{SENSE} and R_{THR} resistor values, see the [Detailed Design Procedure](#) section. The ISO1211 and ISO1212 devices are capable of high speed operation and can pass through a minimum pulse width of 150 ns. The ISO1211 device has a single receive channel. The ISO1212 device has two receive channels that are independent on the field side.

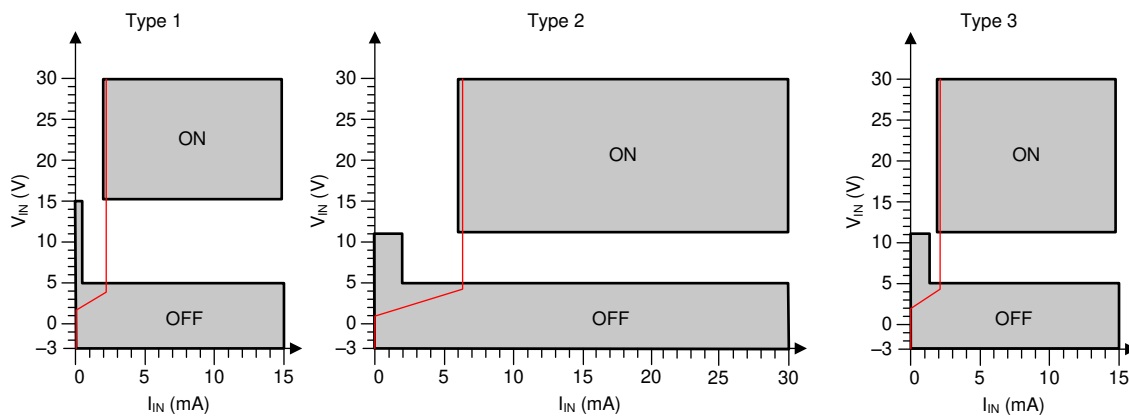

Figure 15. Switching Characteristics for IEC61131-2 Type 1, 2, and 3 Proximity Switches

9.2 Typical Application

9.2.1 Sinking Inputs

Figure 16 shows the design for a typical multichannel, isolated digital-input module with sinking inputs. Push-button switches, proximity sensors, and other field inputs connect to the host controller through an isolated interface. The design is easily scalable from a few channels, such as 4 or 8, to many channels, such as 256 or more. The R_{SENSE} resistor limits the current drawn from the input pins. The R_{THR} resistor is used to adjust the voltage thresholds and limit the peak current during surge events. The C_{IN} capacitor is used to filter noise on the input pins. For more information on selecting R_{SENSE} , R_{THR} , and C_{IN} , see the [Detailed Design Procedure](#) section.

The ISO121x devices derive field-side power from the input pins which eliminates the requirement for a field-side, 24-V input power supply to the module. Similarly, an isolated dc-dc converter creating a field-side power supply from the controller side back plane supply is also eliminated which improves flexibility of system design and reduces system cost.

For systems requiring channel-to-channel isolation on the field side, use the ISO1211 device as shown in Figure 17.

Typical Application (continued)

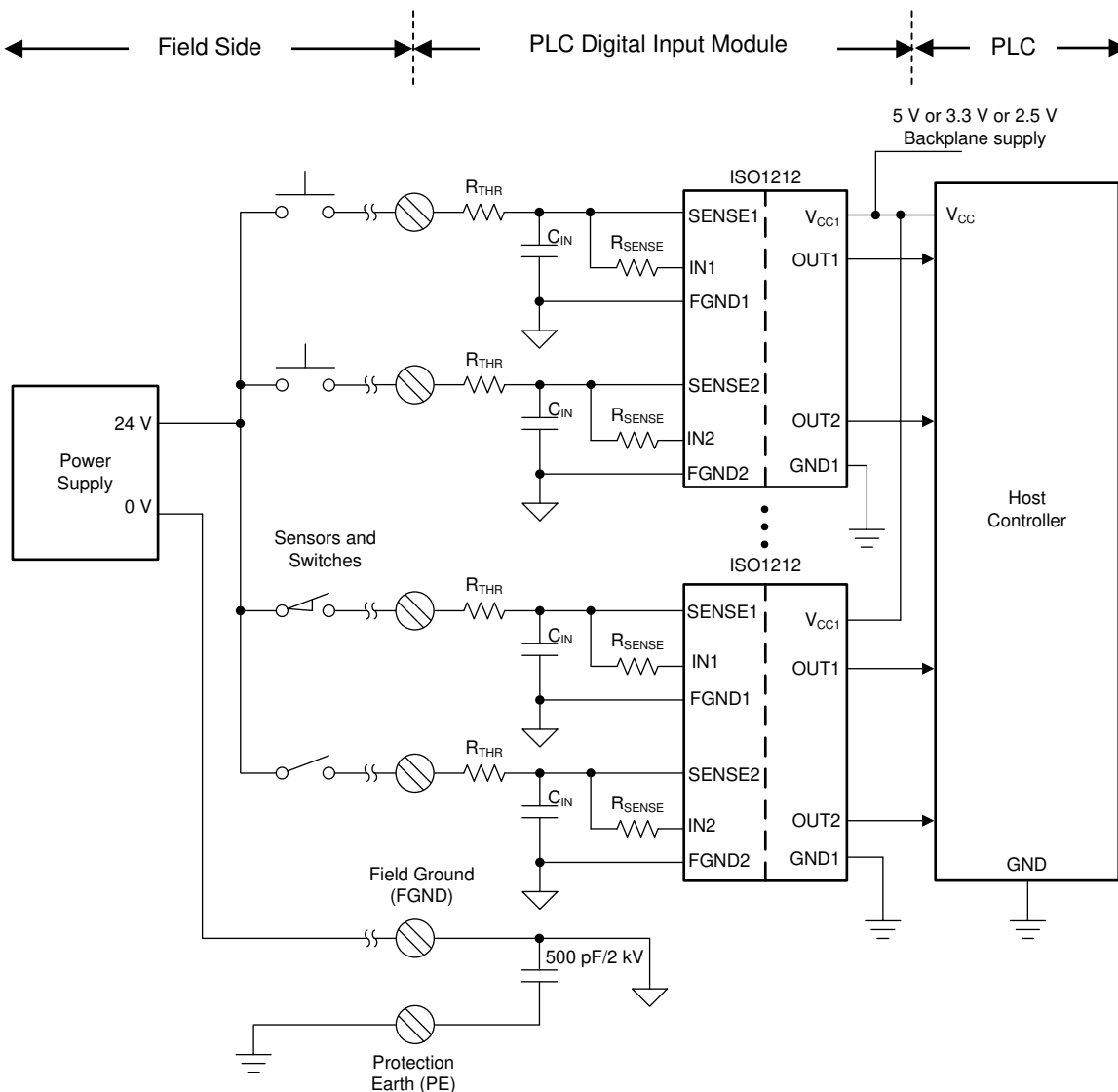

Copyright © 2017, Texas Instruments Incorporated

Figure 16. Typical Application Schematic With Sinking Inputs

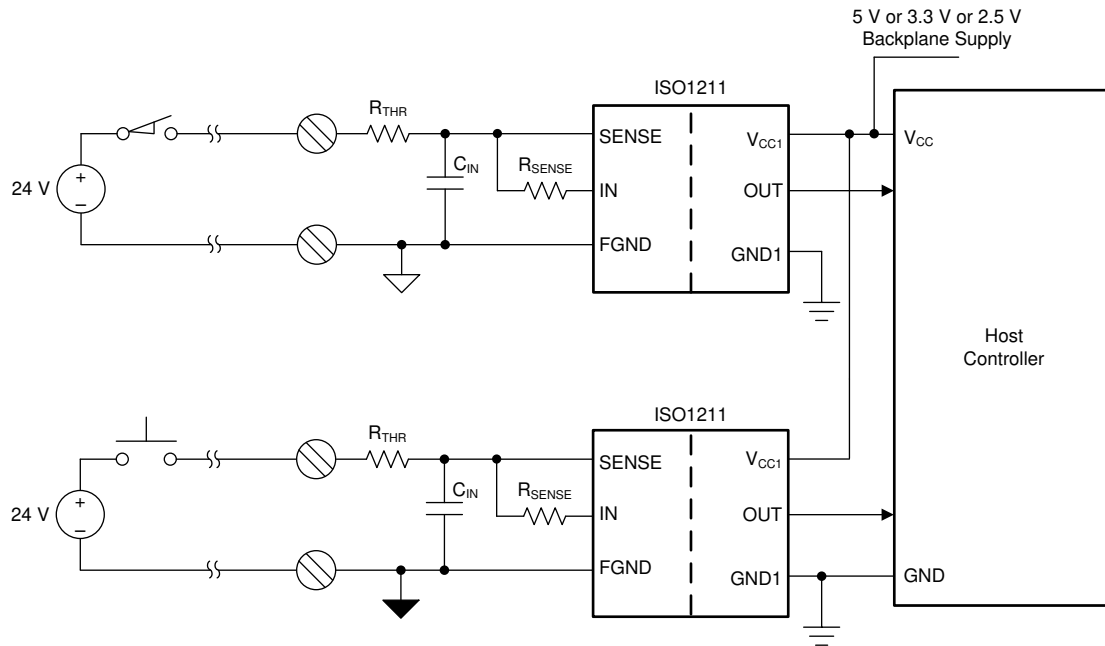
Typical Application (continued)

Copyright © 2017, Texas Instruments Incorporated

Figure 17. Single-Channel or Channel-to-Channel Isolated Designs With ISO1211
9.2.1.1 Design Requirements

The ISO121x devices require two resistors, R_{THR} and R_{SENSE} , and a capacitor, C_{IN} , on the field side. For more information on selecting R_{SENSE} , R_{THR} , and C_{IN} , see the [Detailed Design Procedure](#) section. A 100-nF decoupling capacitor is required on V_{CC1} .

9.2.1.2 Detailed Design Procedure
9.2.1.2.1 Setting Current Limit and Voltage Thresholds

The R_{SENSE} resistor limits the current drawn from the field input. A value of 562 Ω for R_{SENSE} is recommended for Type 1 and Type 3 operation, and results in a current limit of 2.25 mA (typical). A value of 200 Ω for R_{SENSE} is recommended for Type 2 operation, and results in a current limit of 6 mA (typical). In each case, a (slightly) lower value of R_{SENSE} can be selected based on the need for a higher current limit or component availability. For more information, see the [Electrical Characteristics—DC Specification](#) table and [Typical Characteristics](#) section. A 1% tolerance is recommended on R_{SENSE} but 5% resistors can also be used if higher variation in the current limit value is acceptable. The relationship between the R_{SENSE} resistor and the typical current limit (I_L) is given by [Equation 1](#).

$$I_L = \frac{2.25 \text{ mA} \times 562 \Omega}{R_{SENSE}} \quad (1)$$

The R_{THR} resistor sets the voltage thresholds (V_{IL} and V_{IH}) as well as limits the surge current. A value of 1 k Ω is recommended for R_{THR} in Type 3 systems (maximum threshold voltage required is 11 V). A value of 2.5 k Ω is recommended for R_{THR} in Type 1 systems (maximum threshold voltage required is 15 V) and a value of 330 Ω is recommended for R_{THR} in Type 2 systems. The [Electrical Characteristics—DC Specification](#) table lists and the [Typical Characteristics](#) section describes the voltage thresholds with different values of R_{THR} . For other values of R_{THR} , derive the values through linear interpolation. Use [Equation 2](#) and [Equation 3](#) to calculate the values for the typical V_{IH} values and minimum V_{IL} values, respectively.

$$V_{IH} (\text{typ}) = 8.25 \text{ V} + R_{THR} \times \frac{2.25 \text{ mA} \times 562 \Omega}{R_{SENSE}} \quad (2)$$

Typical Application (continued)

$$V_{IL} \text{ (typ)} = 7.1 \text{ V} + R_{THR} \times \frac{2.25 \text{ mA} \times 562 \Omega}{R_{SENSE}} \quad (3)$$

The maximum voltage on the SENSE pins of the ISO121x device is 60 V. However, because the R_{THR} resistor drops additional voltage, the maximum voltage supported at the module inputs is higher and given by Equation 4.

$$V_{IN} \text{ (max)} = 60 \text{ V} + R_{THR} \times \frac{2.1 \text{ mA} \times 562 \Omega}{R_{SENSE}} \quad (4)$$

Use the [ISO121x Threshold Calculator for 9V to 300V DC and AC Voltage Detection](#) to estimate the values of the voltage transition thresholds, the maximum-allowed module input voltage, and module input current for the given values of the R_{SENSE} and R_{THR} resistors.

A value of 0 Ω for R_{THR} also meets Type 1, Type 2 and Type 3 voltage-threshold requirements. The value of R_{THR} should be maximized for best EMC performance while meeting the desired input voltage thresholds. Because R_{THR} is used to limit surge current, 0.25 W MELF resistors must be used.

Figure 18 shows the typical input current characteristics and voltage transition thresholds for 562- Ω R_{SENSE} and 1-k Ω R_{THR} .

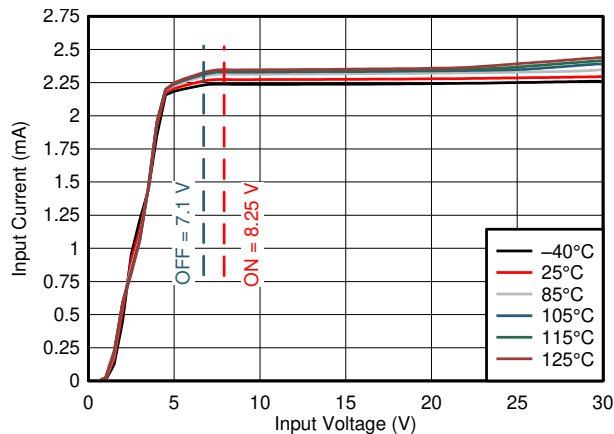

Figure 18. Transition Thresholds

9.2.1.2.2 Thermal Considerations

Thermal considerations constrain operation at different input current and voltage levels. The power dissipated inside the ISO121x devices is determined by the voltage at the SENSE pin (V_{SENSE}) and the current drawn by the device ($I_{(INX+SENSEX)}$). The internal power dissipated, when taken with the junction-to-air thermal resistance defined in the [Thermal Information](#) table can be used to determine the junction temperature for a given ambient temperature. The junction temperature must not exceed 150°C.

Figure 19 shows the maximum allowed ambient temperature for the ISO1211 device for different current limit and input voltage conditions. The ISO1211 device can be used with a V_{SENSE} voltage up to 60 V and an ambient temperature of up to 125°C for an R_{SENSE} value of 562 Ω , which corresponds to a typical current limit of 2.25 mA. At higher levels of current limit, either the ambient temperature or the maximum value of the V_{SENSE} voltage must be derated. In any design, the voltage drop across the external series resistor, R_{THR} , reduces the maximum voltage received by the SENSE pin and helps extend the allowable module input voltage and ambient temperature range.

Typical Application (continued)

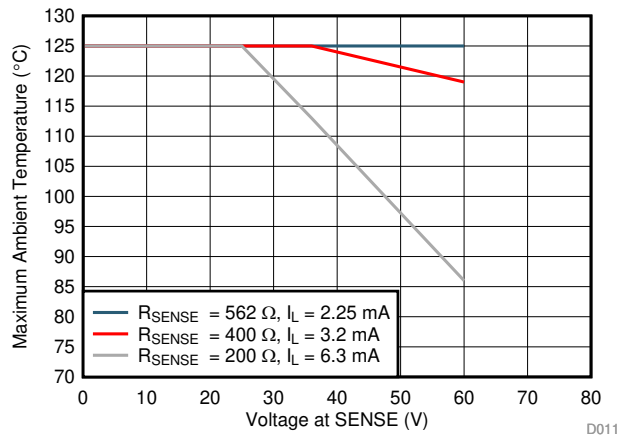

(1) This figure also applies to the ISO1212 device if only one of the two channels are expected to be active at a given time.

Figure 19. Maximum Ambient Temperature Derating Curve for ISO1211 vs V_{SENSE}

Figure 20 shows the maximum allowed ambient temperature for the ISO1212 device for different current limit and input voltage conditions. The ISO1212 device can be used with a V_{SENSE} voltage up to 36 V and an ambient temperature of up to 125°C for an R_{SENSE} value of 562 Ω, which corresponds to a typical current limit of 2.25 mA. At higher current limit levels, either the ambient temperature or the maximum value of the V_{SENSE} voltage must be derated. Operation of the ISO1212 device with an R_{SENSE} value of 200 Ω and with both channels active is not recommended beyond a V_{SENSE} voltage of 36 V. In any design, the voltage drop across the series resistor, R_{THR}, reduces the maximum voltage received by the SENSE pin and helps extend the allowable module input voltage and ambient temperature range.

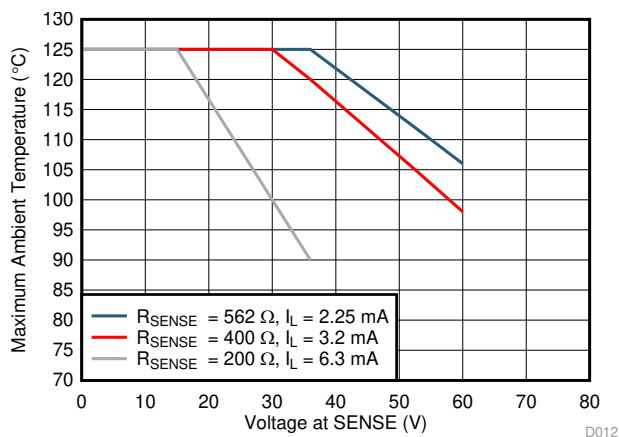

(1) This figure only applies if both channels of the ISO1212 device are expected to be on at the same time. If only one channel is expected to be on at a given time, refer to Figure 19.

Figure 20. Maximum Ambient Temperature Derating Curve for ISO1212 vs V_{SENSE}

Typical Application (continued)

9.2.1.2.3 Designing for 48-V Systems

The ISO121x devices are suitable for 48-V digital input receivers. The current limit, voltage transition thresholds, and maximum voltage supported at the module input are governed by [Equation 1](#), [Equation 2](#), [Equation 3](#), and [Equation 4](#). For 48-V systems, a threshold voltage close to 25 V is desirable. The R_{THR} resistor can be adjusted to achieve this higher threshold. For example, with an R_{SENSE} value of 562 Ω and an R_{THR} value of 7.5 k Ω , a V_{IH} value of approximately 25 V can be achieved. With this setting, the R_{THR} resistor drops a voltage of approximately 17 V, reducing the maximum value of the V_{SENSE} voltage for any given module input voltage. This drop vastly increases the allowable module input voltage and ambient temperature range as discussed in [Thermal Considerations](#).

9.2.1.2.4 Designing for Input Voltages Greater Than 60 V

The ISO121x devices are rated for 60 V on the SENSE and IN pins with respect to FGND. However, larger voltages on the module input can be supported by dropping extra voltage across an external resistor, R_{THR} . Because the current drawn by the SENSE and IN pins is well controlled by the built-in current limit, the voltage drop across R_{THR} is well controlled as well. However, increasing the R_{THR} resistance also correspondingly raises the voltage transition threshold. An additional resistor, R_{SHUNT} (see [Figure 21](#)), provides the flexibility to change the voltage transition thresholds independently of the maximum input voltage. The current through the R_{SHUNT} resistor is less near the voltage transition threshold, but increases with the input voltage, increasing the voltage drop across the R_{THR} resistor, and preventing the voltage on the ISO121x pins from exceeding 60 V. With the correct value selected for the R_{THR} and R_{SHUNT} resistors, the voltage transition thresholds and the maximum input voltage supported can be adjusted independently.

A 1-nF or greater C_{IN} capacitor is recommended between the SENSE and FGND pins to slow down the transitions on the SENSE pin, and to prevent overshoot beyond 60 V during transitions.

For more information, refer to the [How to Design Isolated Comparators for \$\pm 48V\$, 110V and 240V DC and AC Detection TI TechNote](#). Use the [ISO121x Threshold Calculator for 9V to 300V DC and AC Voltage Detection](#) to estimate the values of voltage transition thresholds, the maximum-allowed module input voltage, and module input current for given values of the R_{SENSE} , R_{THR} , and R_{SHUNT} resistors.

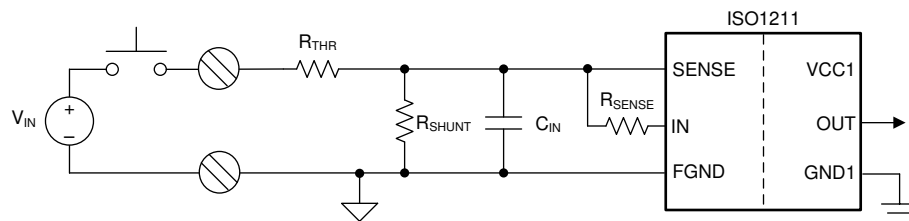

Figure 21. Increase ISO121x Input Voltage Range With R_{SHUNT}

Another way to increase the maximum module input voltage without changing the voltage transition thresholds is to use a 60-V Zener diode to limit the voltage on the ISO121x pins to less than 60 V as shown in [Figure 22](#). In this case, when the module input is greater than 60 V, the Zener diode must be designed to sink the additional current, and the R_{THR} resistor must be designed to drop a higher voltage.

For example, with a 2.5-k Ω R_{THR} and 560- Ω R_{SENSE} , the voltage transition threshold is 15 V, and the ISO121x input current is 2.25 mA. If the module voltage reaches 100 V, the voltage drop across the R_{THR} resistor is 40 V, and the current through the Zener diode is approximately 14 mA.

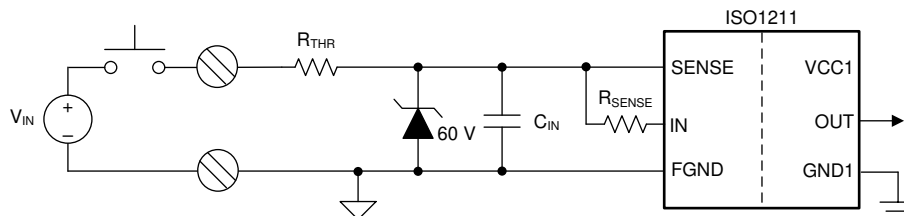

Figure 22. Increase ISO121x Input Voltage Range Using a Zener Diode

Typical Application (continued)

9.2.1.2.5 Surge, ESD, and EFT Tests

Digital input modules are subject to surge (IEC 61000-4-5), electrostatic discharge or ESD (IEC 61000-4-2) and electrical fast transient or EFT (IEC 61000-4-4) tests. The surge impulse waveform has the highest energy and the widest pulse width, and is therefore the most stringent test of the three.

Figure 16 shows the application diagram for Type 1 and 3 systems. For a 1-kV_{PP} surge test between the input terminals and protection earth (PE), a value of 1 kΩ for R_{THR} and 10 nF for C_{IN} is recommended. Table 3 lists a summary of recommended component values to meet different levels of EMC requirements for Type 1 and 3 systems.

Table 3. Surge, IEC ESD and EFT

IEC 61131-2 TYPE	R _{SENSE}	R _{TH}	C _{IN}	SURGE			IEC ESD	IEC EFT
				LINE-TO-PE	LINE-TO-LINE	LINE-TO-FGND		
Type 1	562	2.5 kΩ	10 nF	±1 kV	±1 kV	±1 kV	±6 kV	±4 kV
Type 3	562	1 kΩ	10 nF	±1 kV	±1 kV	±500 V	±6 kV	±4 kV
			330 nF	±1 kV	±1 kV	±1 kV	±6 kV	±4 kV

Figure 23 shows the test setup and application circuit used for surge testing. A noise filtering capacitor of 500 pF is recommended between the FGND pin and PE (earth). The total value of effective capacitance between the FGND pin and any other ground potential (including PE) must not exceed 500 pF for optimum surge performance. For line-to-PE test (common-mode test), the FGND pin is connected to the auxiliary equipment (AE) through a decoupling network.

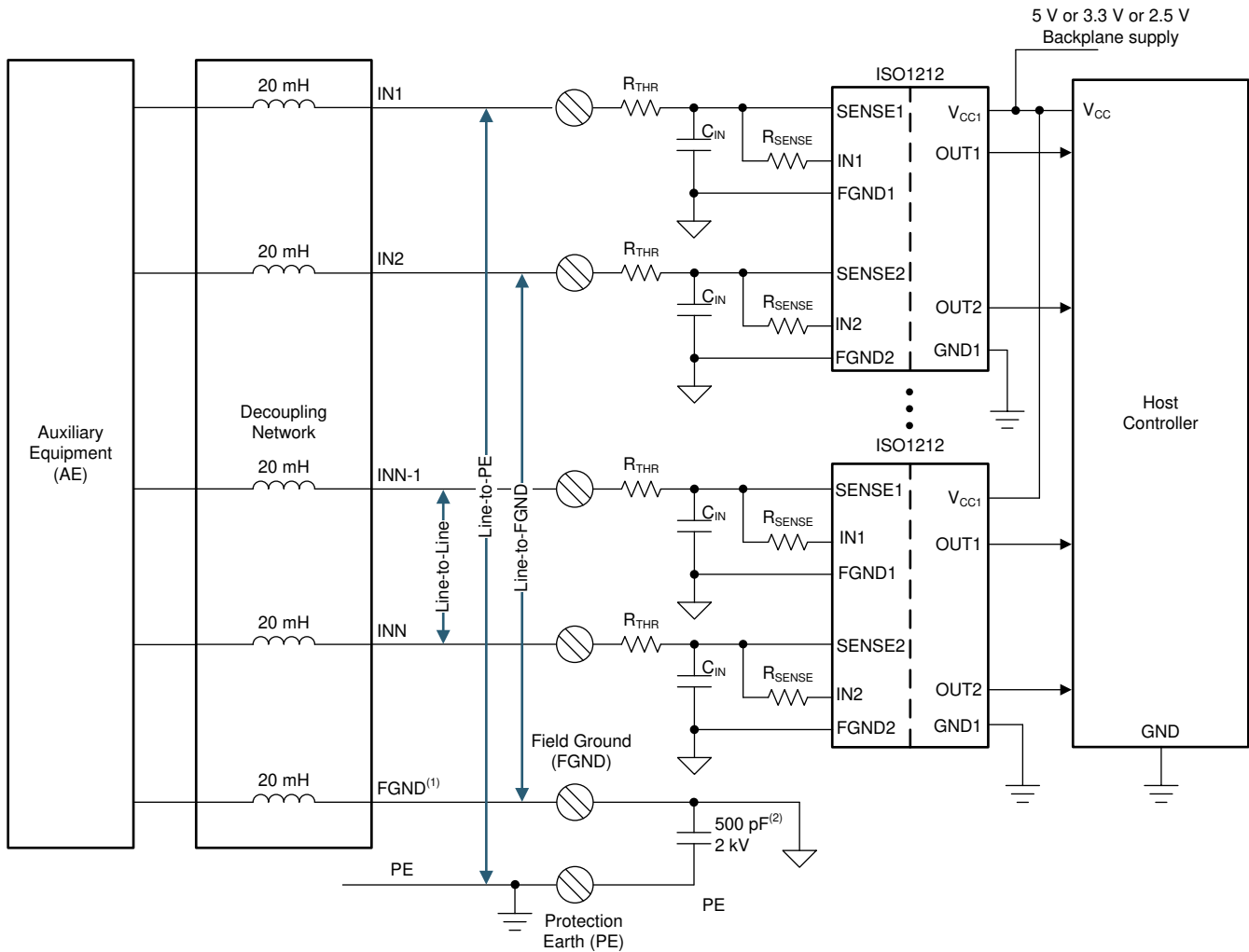

Copyright © 2017, Texas Instruments Incorporated

- (1) For line-to-PE test, FGND is connected to the auxiliary equipment (AE) through a decoupling network.
- (2) A noise filtering capacitor of about 500 pF is recommended between the FGND pin and PE (earth). The total value of effective capacitance between the FGND pin and any other ground potential (including PE) must not exceed 500 pF for optimum performance.

Figure 23. Setup and Application Circuit Used for Surge Test

For higher voltage levels of surge tests or for faster systems that cannot use a large value for C_{IN} , TVS diodes or varistors can be used to meet EMC requirements. Type 2 systems that use a smaller value for R_{THR} may also require TVS diodes or varistors for surge protection. Figure 24 shows an example usage of TVS diodes for surge protection. The recommended components for surge protection are VCAN26A2-03S (TVS, Vishay), EZJ-P0V420WM (Varistor, Panasonic), and GSOT36C (TVS, Vishay).

Use of the R_{THR} resistor also reduces the peak current requirement for the TVS diodes, making them smaller and cost effective. For example, a 2-kV surge through a 1-k Ω R_{THR} resistor creates only 2-A peak current. Also, because of voltage drop across the R_{THR} resistor in normal operation, the working voltage requirement for the varistor or TVS diodes is reduced. For example, for a R_{THR} value of 1 k Ω and an R_{SENSE} value of 562 Ω , a module designed for 30-V inputs only requires 28-V TVS diodes because the R_{THR} resistor drops more than 2 V.

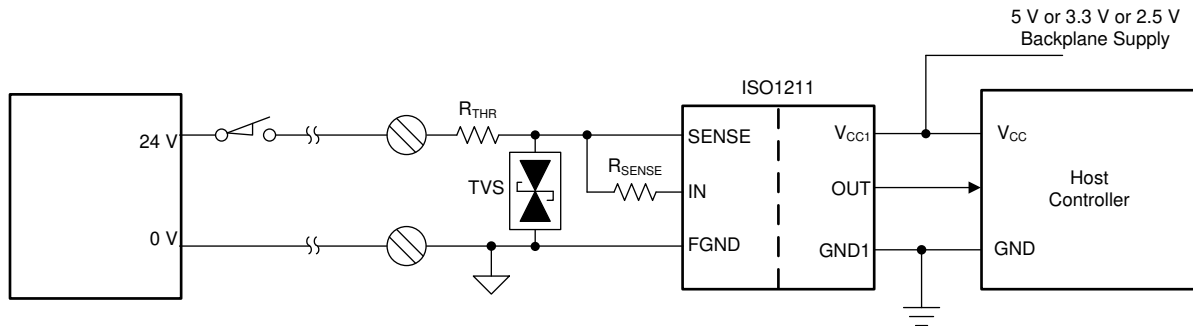

Copyright © 2017, Texas Instruments Incorporated

Figure 24. TVS Diodes Used Instead of a Filtering Capacitor for Surge Protection in Faster Systems

9.2.1.2.6 Multiplexing the Interface to the Host Controller

The ISO121x devices provide an output-enable pin on the controller side (EN). Setting the EN pin to 0 causes the output buffers to be in the high-impedance state. This feature can be used to multiplex the outputs of multiple ISO121x devices on the same host-controller input, reducing the number of pins on the host controller.

In the example shown in Figure 25, two sets of 8-channel inputs are multiplexed, reducing the number of input pins required on the controller from 16 to 10. Similarly, if four sets of 8-channel inputs are multiplexed, the number of pins on the controller is reduced from 32 to 12.

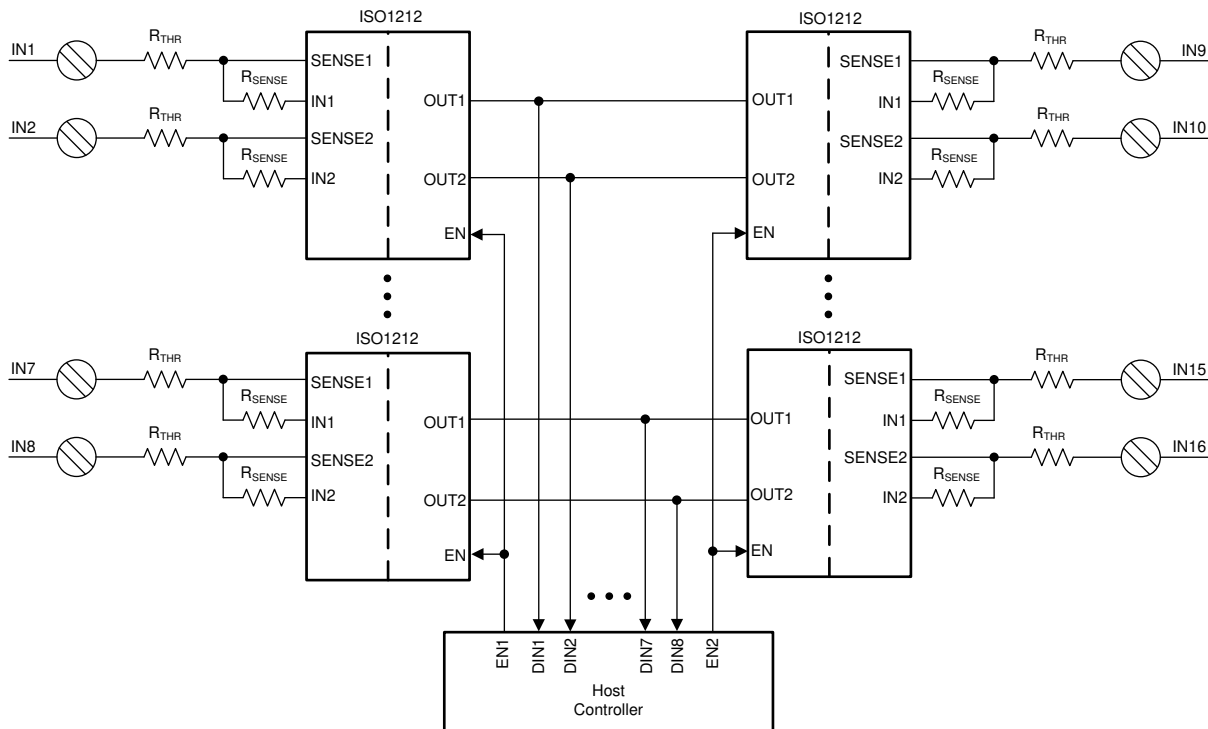

Copyright © 2017, Texas Instruments Incorporated

Figure 25. Using the Output Enable Option to Multiplex the Interface to the Host Controller

9.2.1.2.7 Status LEDs

The outputs of the ISO121x devices can be used to drive status LEDs on the controller side as shown in Figure 26. The output buffers of the ISO121x can provide 4-mA, 3-mA, and 2-mA currents while working at V_{CC1} values of 5 V, 3.3 V, and 2.5 V respectively.

In some cases, placing the LED on the field side is desirable although it is powered from V_{CC1} . In such cases, the signal carrying current to the LED can be routed in an inner layer without compromising the isolation of the digital-input module. For more information, see the *Layout Guidelines* section.

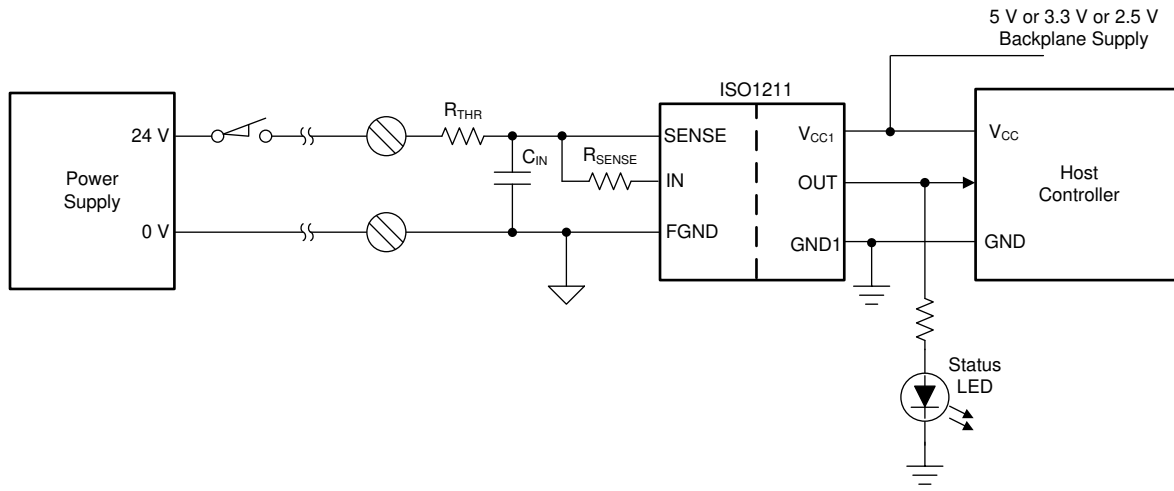

Copyright © 2017, Texas Instruments Incorporated

Figure 26. Using ISO121x Outputs to Drive Status LEDs

9.2.1.3 Application Curve

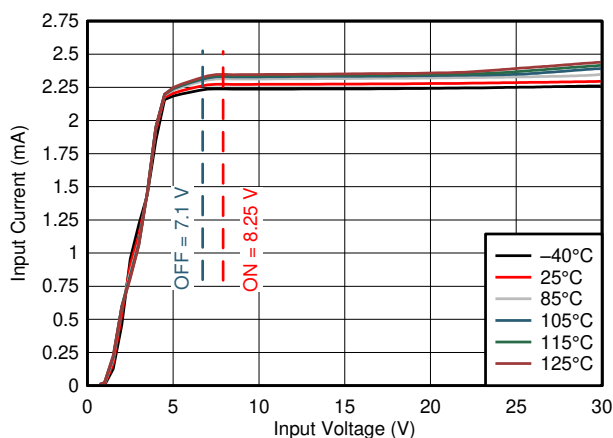

$R_{SENSE} = 562 \Omega$ $R_{THR} = 0 \Omega$

Figure 27. Input Current vs Input Voltage

9.2.2 Sourcing Inputs

The ISO121x devices can be configured as sourcing inputs as shown in Figure 28. In this configuration, all the SENSE pins are connected to the common voltage (24 V), and the inputs are connected to the individual FGND pins.

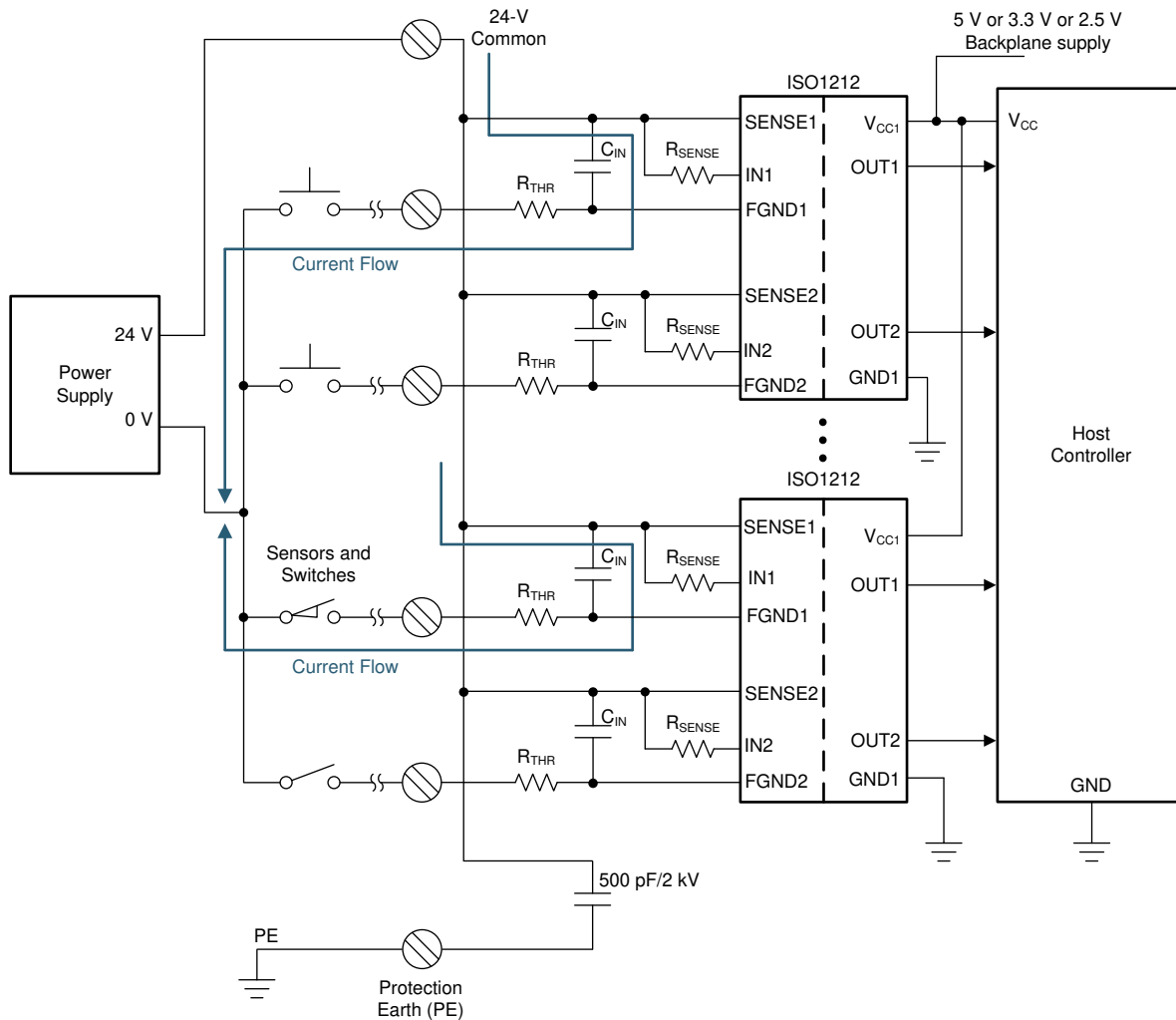

Copyright © 2017, Texas Instruments Incorporated

Figure 28. Typical Application Circuit With Sourcing Inputs

9.2.3 Sourcing and Sinking Inputs (Bidirectional Inputs)

The ISO1212 device can be used to create a bidirectional input module that can sink and source current as shown in Figure 29. In this configuration, channel 1 is active if the COM terminal is connected to ground for sinking inputs, and channel 2 is active if the COM terminal is connected to 24 V for sourcing input. The digital input is considered high if either the OUT1 or OUT2 pin is high.

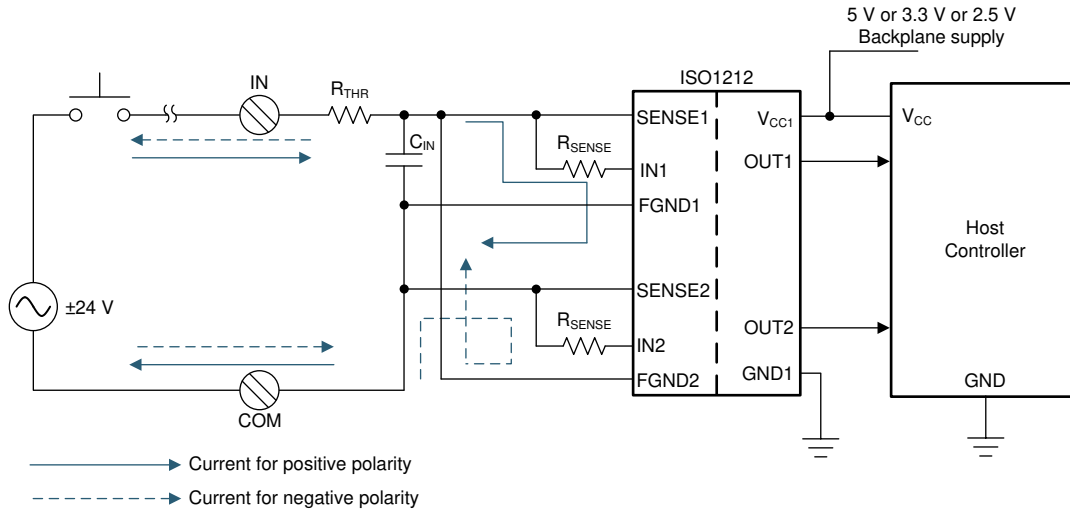

Copyright © 2017, Texas Instruments Incorporated

Figure 29. Application Circuit—ISO1212 With Sourcing and Sinking Inputs

A bidirectional input module can also be built with the ISO121x devices using low-cost Schottky diodes as shown in Figure 30.

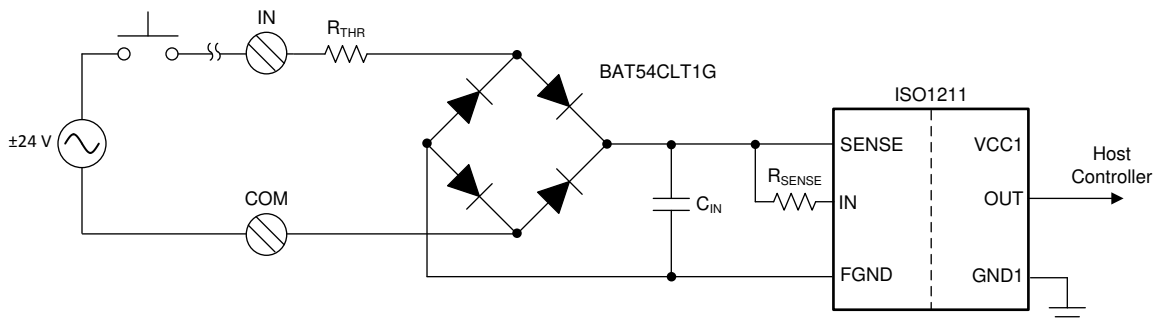

Figure 30. Bidirectional Implementation With ISO1211 and Bridge Rectifier

10 Power Supply Recommendations

To help ensure reliable operation at data rates and supply voltages, a 0.1- μ F bypass capacitor is recommended on the side 1 supply pin (V_{CC1}). The capacitor should be placed as close to the supply pins as possible.

11 Layout

11.1 Layout Guidelines

The board layout for ISO1211 and ISO1212 can be completed in two layers. On the field side, place R_{SENSE} , C_{IN} , and R_{THR} on the top layer. Use the bottom layer as the field ground (FGND) plane. TI recommends using R_{SENSE} and C_{IN} in 0603 footprint for a compact layout, although larger sizes (0805) can also be used. The C_{IN} capacitor is a 50-V capacitor and is available in the 0603 footprint. Keep C_{IN} as close to the ISO121x device as possible. The SUB pin on the ISO1211 device and the SUB1 and SUB2 pins on the ISO1212 device should be left unconnected. For group isolated design, use vias to connect the FGND pins of the ISO121x device to the bottom FGND plane. The placement of the R_{THR} resistor is flexible, although the resistor pin connected to external high voltage should not be placed within 4 mm of the ISO121x device pins or the C_{IN} and R_{SENSE} pins to avoid flashover during EMC tests.

Only a decoupling capacitor is required on side 1. Place this capacitor on the top-layer, with the bottom layer for GND1.

If a board with more than two layers is used, placing two ISO121x devices on the top-and bottom layers (back-to-back) is possible to achieve a more compact board. The inner layers can be used for FGND.

Figure 31 and Figure 32 show the example layouts.

In some designs, placing the LED on the field side is desirable although it is powered from V_{CC1} . In such cases, the signal carrying current to the LED can be routed in an inner layer without compromising the isolation of the digital-input module as shown in Figure 33. The LED must be placed with at least 4-mm spacing between other components and connections on side 1 to ensure adequate isolation.

11.2 Layout Example

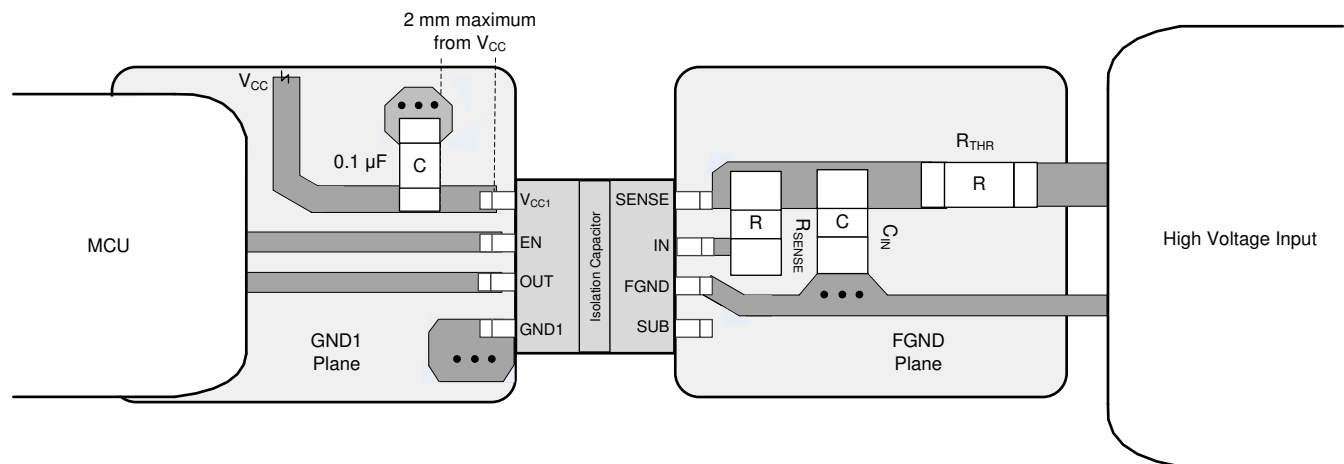

Figure 31. Layout Example With ISO1211

Layout Example (continued)

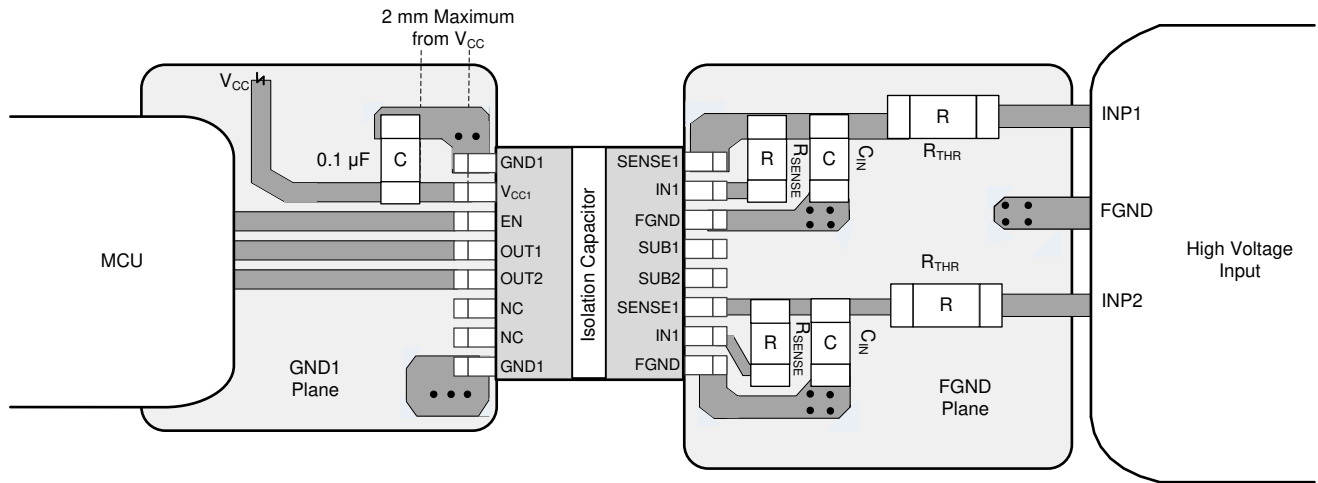

Figure 32. Layout Example With ISO1212

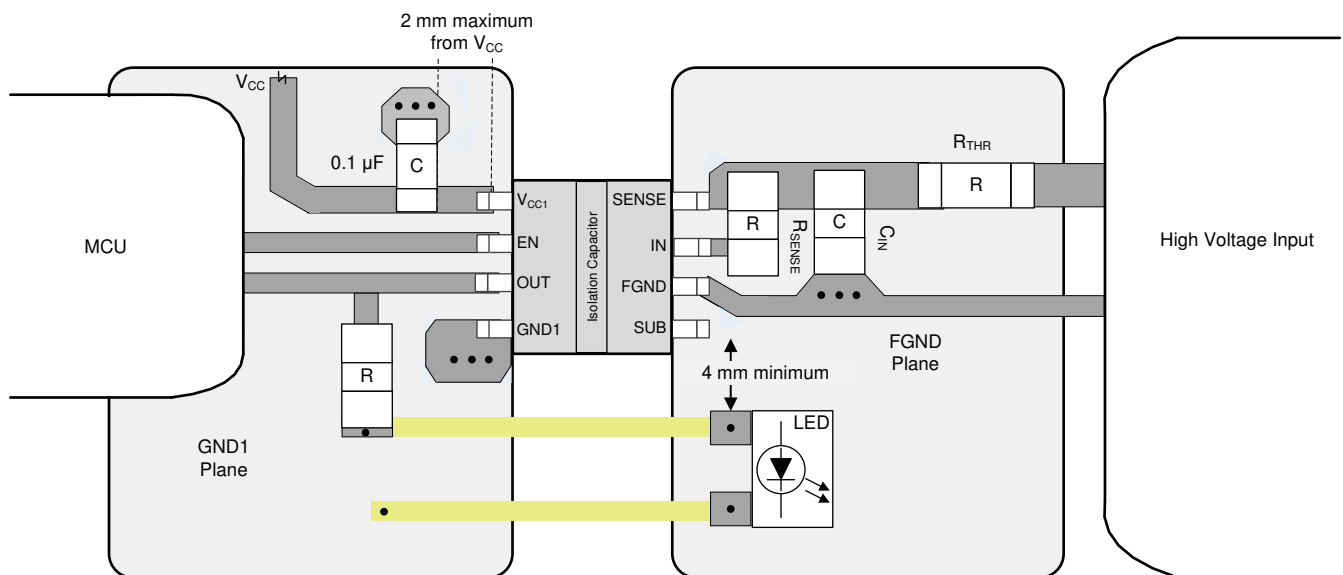

Figure 33. Layout Example With LED Placed on the Field Side But Driven From V_{CC1} Power Domain

12 Device and Documentation Support

12.1 Device Support

12.1.1 Development Support

For development support, refer to:

- [Sub 1-W, 16-Channel, Isolated Digital Input Module Reference Design](#)
- [Broken Wire Detection Using An Optical Switch Reference Design](#)
- [Redundant Dual Channel Reference Design for Safe Torque Off in Variable Speed Drives](#)

12.2 Documentation Support

12.2.1 Related Documentation

For related documentation see the following:

- Texas Instruments, [How To Improve Speed and Reliability of Isolated Digital Inputs in Motor Drives TI TechNote](#)
- Texas Instruments, [How to Design Isolated Comparators for ±48V, 110V and 240V DC and AC Detection TI TechNote](#)
- Texas Instruments, [How To Simplify Isolated 24-V PLC Digital Input Module Designs TI TechNote](#)
- Texas Instruments, [Isolation Glossary](#)
- Texas Instruments, [ISO121x Threshold Calculator for 9V to 300V DC and AC Voltage Detection](#)
- Texas Instruments, [ISO1211 Isolated Digital-Input Receiver Evaluation Module user's guide](#)
- Texas Instruments, [ISO1212 Isolated Digital-Input Receiver Evaluation Module user's guide](#)

12.3 Related Links

The table below lists quick access links. Categories include technical documents, support and community resources, tools and software, and quick access to order now.

Table 4. Related Links

PARTS	PRODUCT FOLDER	ORDER NOW	TECHNICAL DOCUMENTS	TOOLS & SOFTWARE	SUPPORT & COMMUNITY
ISO1211	Click here	Click here	Click here	Click here	Click here
ISO1212	Click here	Click here	Click here	Click here	Click here

12.4 Receiving Notification of Documentation Updates

To receive notification of documentation updates, navigate to the device product folder on ti.com. In the upper right corner, click on *Alert me* to register and receive a weekly digest of any product information that has changed. For change details, review the revision history included in any revised document.

12.5 Community Resource

[TI E2E™ support forums](#) are an engineer's go-to source for fast, verified answers and design help — straight from the experts. Search existing answers or ask your own question to get the quick design help you need.

Linked content is provided "AS IS" by the respective contributors. They do not constitute TI specifications and do not necessarily reflect TI's views; see TI's [Terms of Use](#).

12.6 Trademarks

E2E is a trademark of Texas Instruments.

All other trademarks are the property of their respective owners.

12.7 Electrostatic Discharge Caution



This integrated circuit can be damaged by ESD. Texas Instruments recommends that all integrated circuits be handled with appropriate precautions. Failure to observe proper handling and installation procedures can cause damage.

ESD damage can range from subtle performance degradation to complete device failure. Precision integrated circuits may be more susceptible to damage because very small parametric changes could cause the device not to meet its published specifications.

12.8 Glossary

[SLYZ022](#) — *TI Glossary*.

This glossary lists and explains terms, acronyms, and definitions.

13 Mechanical, Packaging, and Orderable Information

The following pages include mechanical packaging and orderable information. This information is the most current data available for the designated devices. This data is subject to change without notice and revision of this document. For browser-based versions of this data sheet, refer to the left-hand navigation.

PACKAGING INFORMATION

Orderable Device	Status (1)	Package Type	Package Drawing	Pins	Package Qty	Eco Plan (2)	Lead finish/ Ball material (6)	MSL Peak Temp (3)	Op Temp (°C)	Device Marking (4/5)	Samples
ISO1211D	ACTIVE	SOIC	D	8	75	RoHS & Green	NIPDAU	Level-2-260C-1 YEAR	-40 to 125	1211	Samples
ISO1211DR	ACTIVE	SOIC	D	8	2500	RoHS & Green	NIPDAU	Level-2-260C-1 YEAR	-40 to 125	1211	Samples
ISO1212DBQ	ACTIVE	SSOP	DBQ	16	75	RoHS & Green	NIPDAU	Level-2-260C-1 YEAR	-40 to 125	1212	Samples
ISO1212DBQR	ACTIVE	SSOP	DBQ	16	2500	RoHS & Green	NIPDAU	Level-2-260C-1 YEAR	-40 to 125	1212	Samples

(1) The marketing status values are defined as follows:

ACTIVE: Product device recommended for new designs.

LIFEBUY: TI has announced that the device will be discontinued, and a lifetime-buy period is in effect.

NRND: Not recommended for new designs. Device is in production to support existing customers, but TI does not recommend using this part in a new design.

PREVIEW: Device has been announced but is not in production. Samples may or may not be available.

OBSOLETE: TI has discontinued the production of the device.

(2) **RoHS:** TI defines "RoHS" to mean semiconductor products that are compliant with the current EU RoHS requirements for all 10 RoHS substances, including the requirement that RoHS substance do not exceed 0.1% by weight in homogeneous materials. Where designed to be soldered at high temperatures, "RoHS" products are suitable for use in specified lead-free processes. TI may reference these types of products as "Pb-Free".

RoHS Exempt: TI defines "RoHS Exempt" to mean products that contain lead but are compliant with EU RoHS pursuant to a specific EU RoHS exemption.

Green: TI defines "Green" to mean the content of Chlorine (Cl) and Bromine (Br) based flame retardants meet JS709B low halogen requirements of <=1000ppm threshold. Antimony trioxide based flame retardants must also meet the <=1000ppm threshold requirement.

(3) **MSL, Peak Temp.** - The Moisture Sensitivity Level rating according to the JEDEC industry standard classifications, and peak solder temperature.

(4) There may be additional marking, which relates to the logo, the lot trace code information, or the environmental category on the device.

(5) Multiple Device Markings will be inside parentheses. Only one Device Marking contained in parentheses and separated by a "-" will appear on a device. If a line is indented then it is a continuation of the previous line and the two combined represent the entire Device Marking for that device.

(6) **Lead finish/Ball material** - Orderable Devices may have multiple material finish options. Finish options are separated by a vertical ruled line. Lead finish/Ball material values may wrap to two lines if the finish value exceeds the maximum column width.

Important Information and Disclaimer:The information provided on this page represents TI's knowledge and belief as of the date that it is provided. TI bases its knowledge and belief on information provided by third parties, and makes no representation or warranty as to the accuracy of such information. Efforts are underway to better integrate information from third parties. TI has taken and

continues to take reasonable steps to provide representative and accurate information but may not have conducted destructive testing or chemical analysis on incoming materials and chemicals. TI and TI suppliers consider certain information to be proprietary, and thus CAS numbers and other limited information may not be available for release.

In no event shall TI's liability arising out of such information exceed the total purchase price of the TI part(s) at issue in this document sold by TI to Customer on an annual basis.

TAPE AND REEL INFORMATION

QUADRANT ASSIGNMENTS FOR PIN 1 ORIENTATION IN TAPE



*All dimensions are nominal

Device	Package Type	Package Drawing	Pins	SPQ	Reel Diameter (mm)	Reel Width W1 (mm)	A0 (mm)	B0 (mm)	K0 (mm)	P1 (mm)	W (mm)	Pin1 Quadrant
ISO1211DR	SOIC	D	8	2500	330.0	12.4	6.4	5.2	2.1	8.0	12.0	Q1
ISO1212DBQR	SSOP	DBQ	16	2500	330.0	12.4	6.4	5.2	2.1	8.0	12.0	Q1

TAPE AND REEL BOX DIMENSIONS

*All dimensions are nominal

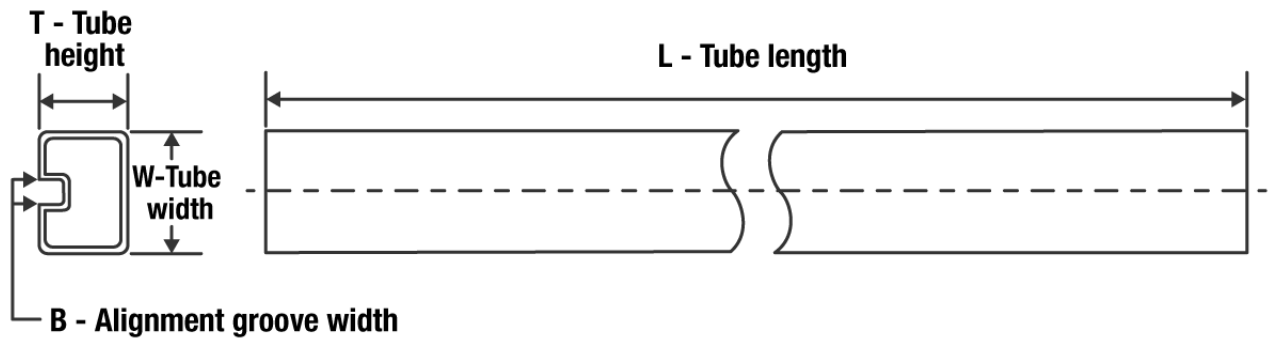
Device	Package Type	Package Drawing	Pins	SPQ	Length (mm)	Width (mm)	Height (mm)
ISO1211DR	SOIC	D	8	2500	350.0	350.0	43.0
ISO1212DBQR	SSOP	DBQ	16	2500	350.0	350.0	43.0

TUBE

*All dimensions are nominal

Device	Package Name	Package Type	Pins	SPQ	L (mm)	W (mm)	T (μm)	B (mm)
ISO1211D	D	SOIC	8	75	505.46	6.76	3810	4
ISO1212DBQ	DBQ	SSOP	16	75	505.46	6.76	3810	4

D0008A



PACKAGE OUTLINE

SOIC - 1.75 mm max height

SMALL OUTLINE INTEGRATED CIRCUIT

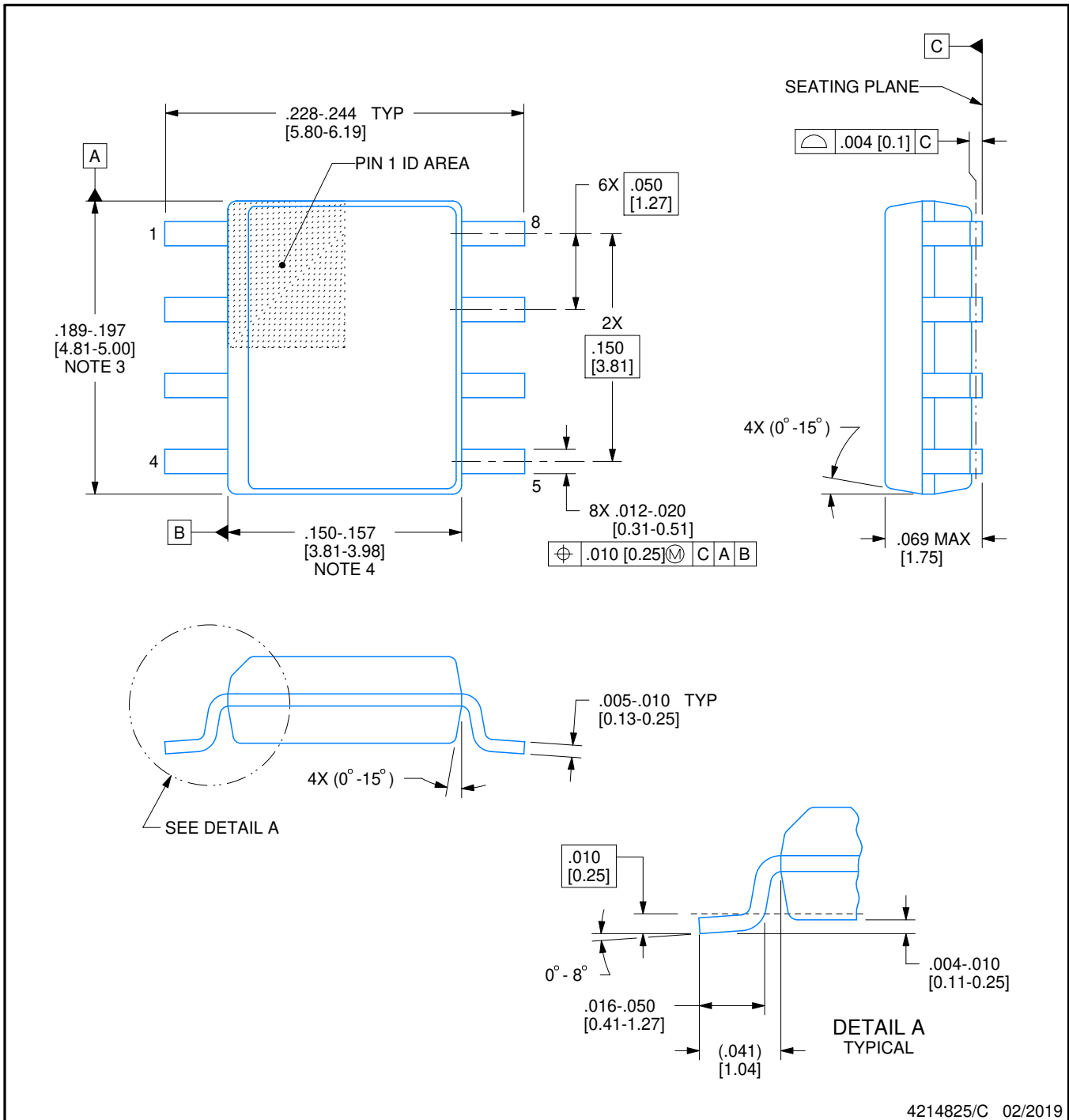

4214825/C 02/2019

NOTES:

1. Linear dimensions are in inches [millimeters]. Dimensions in parenthesis are for reference only. Controlling dimensions are in inches. Dimensioning and tolerancing per ASME Y14.5M.
2. This drawing is subject to change without notice.
3. This dimension does not include mold flash, protrusions, or gate burrs. Mold flash, protrusions, or gate burrs shall not exceed .006 [0.15] per side.
4. This dimension does not include interlead flash.
5. Reference JEDEC registration MS-012, variation AA.

EXAMPLE BOARD LAYOUT

D0008A

SOIC - 1.75 mm max height

SMALL OUTLINE INTEGRATED CIRCUIT



LAND PATTERN EXAMPLE
EXPOSED METAL SHOWN
SCALE:8X



SOLDER MASK DETAILS

4214825/C 02/2019

NOTES: (continued)

- 6. Publication IPC-7351 may have alternate designs.
- 7. Solder mask tolerances between and around signal pads can vary based on board fabrication site.

EXAMPLE STENCIL DESIGN

D0008A

SOIC - 1.75 mm max height

SMALL OUTLINE INTEGRATED CIRCUIT

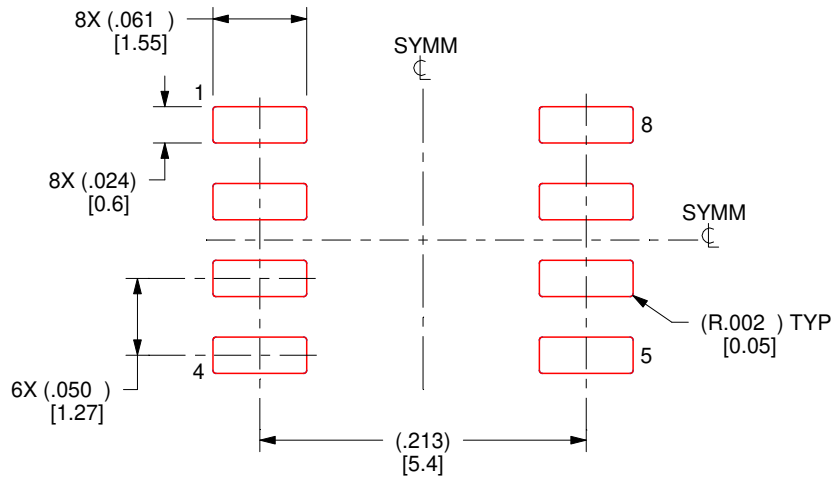

SOLDER PASTE EXAMPLE
BASED ON .005 INCH [0.125 MM] THICK STENCIL
SCALE:8X

4214825/C 02/2019

NOTES: (continued)

8. Laser cutting apertures with trapezoidal walls and rounded corners may offer better paste release. IPC-7525 may have alternate design recommendations.
9. Board assembly site may have different recommendations for stencil design.



DBQ0016A

PACKAGE OUTLINE

SSOP - 1.75 mm max height

SHRINK SMALL-OUTLINE PACKAGE

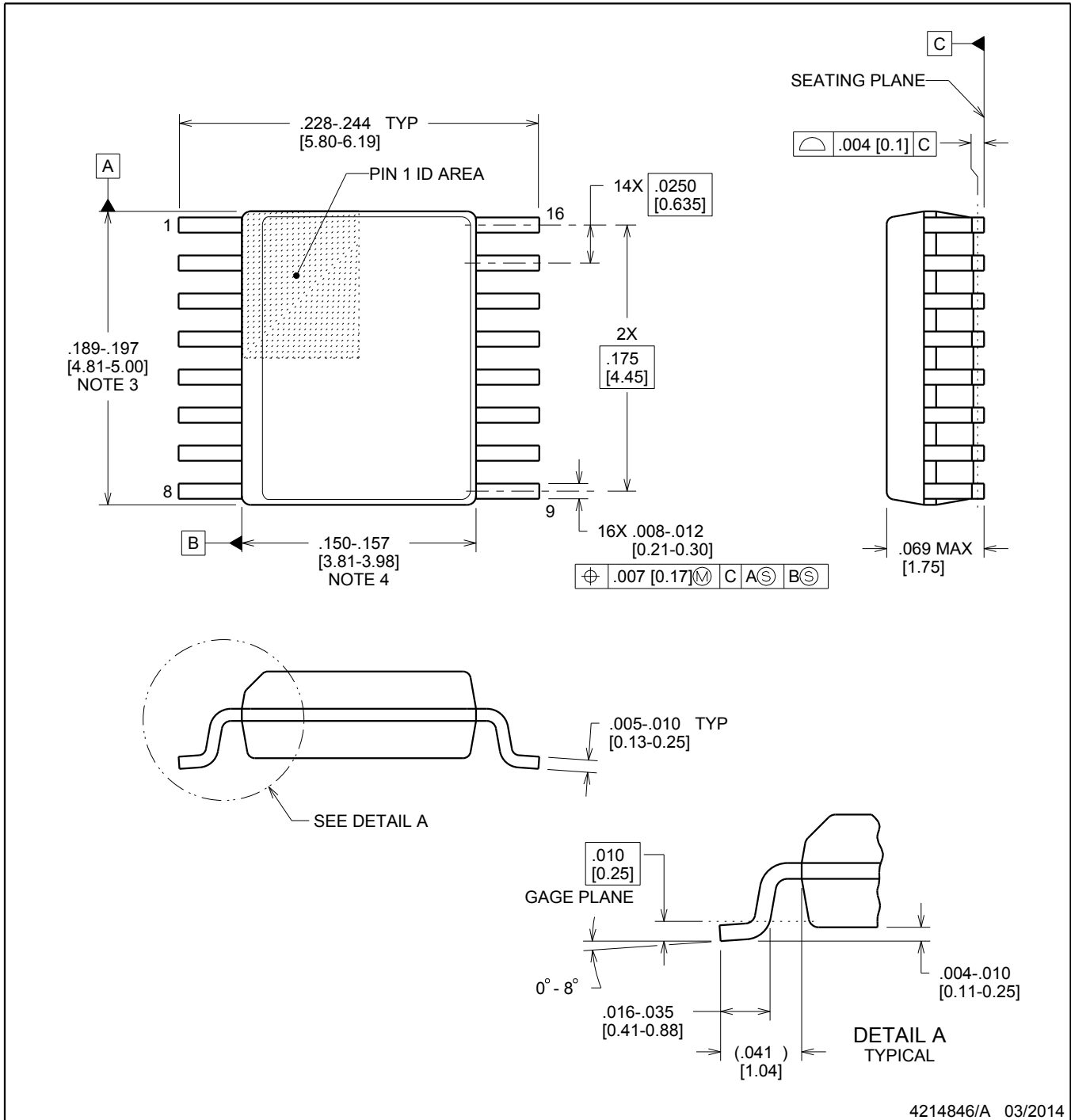

NOTES:

- Linear dimensions are in inches [millimeters]. Dimensions in parenthesis are for reference only. Controlling dimensions are in inches. Dimensioning and tolerancing per ASME Y14.5M.
- This drawing is subject to change without notice.
- This dimension does not include mold flash, protrusions, or gate burrs. Mold flash, protrusions, or gate burrs shall not exceed .006 inch, per side.
- This dimension does not include interlead flash.
- Reference JEDEC registration MO-137, variation AB.

EXAMPLE BOARD LAYOUT

DBQ0016A

SSOP - 1.75 mm max height

SHRINK SMALL-OUTLINE PACKAGE

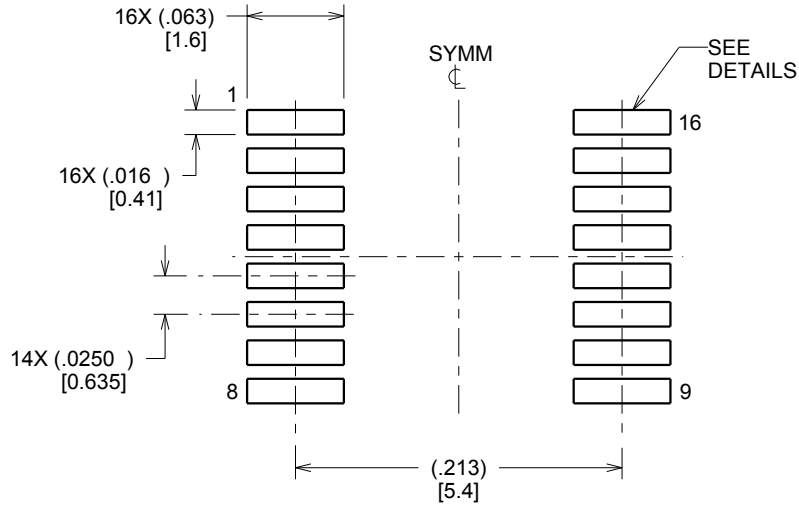

LAND PATTERN EXAMPLE
SCALE:8X

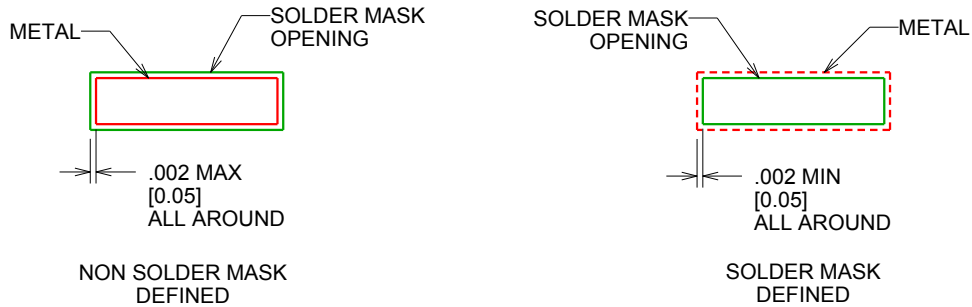

SOLDER MASK DETAILS

4214846/A 03/2014

NOTES: (continued)

6. Publication IPC-7351 may have alternate designs.

7. Solder mask tolerances between and around signal pads can vary based on board fabrication site.

EXAMPLE STENCIL DESIGN

DBQ0016A

SSOP - 1.75 mm max height

SHRINK SMALL-OUTLINE PACKAGE

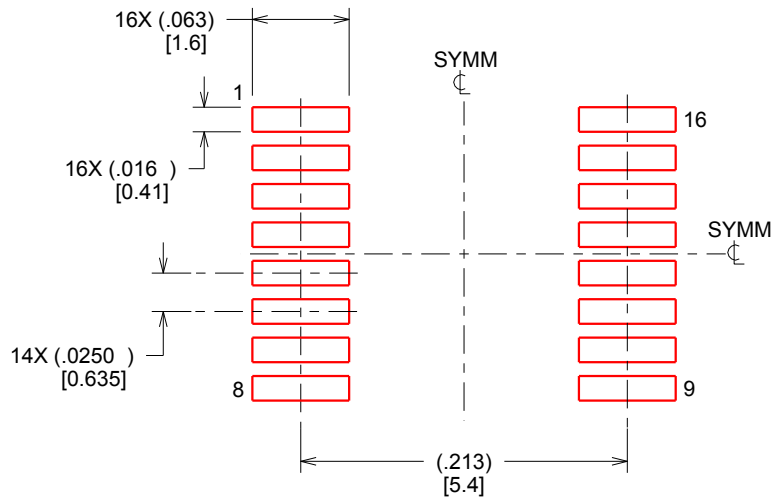

SOLDER PASTE EXAMPLE
BASED ON .005 INCH [0.127 MM] THICK STENCIL
SCALE:8X

4214846/A 03/2014

NOTES: (continued)

8. Laser cutting apertures with trapezoidal walls and rounded corners may offer better paste release. IPC-7525 may have alternate design recommendations.
9. Board assembly site may have different recommendations for stencil design.

IMPORTANT NOTICE AND DISCLAIMER

TI PROVIDES TECHNICAL AND RELIABILITY DATA (INCLUDING DATA SHEETS), DESIGN RESOURCES (INCLUDING REFERENCE DESIGNS), APPLICATION OR OTHER DESIGN ADVICE, WEB TOOLS, SAFETY INFORMATION, AND OTHER RESOURCES "AS IS" AND WITH ALL FAULTS, AND DISCLAIMS ALL WARRANTIES, EXPRESS AND IMPLIED, INCLUDING WITHOUT LIMITATION ANY IMPLIED WARRANTIES OF MERCHANTABILITY, FITNESS FOR A PARTICULAR PURPOSE OR NON-INFRINGEMENT OF THIRD PARTY INTELLECTUAL PROPERTY RIGHTS.

These resources are intended for skilled developers designing with TI products. You are solely responsible for (1) selecting the appropriate TI products for your application, (2) designing, validating and testing your application, and (3) ensuring your application meets applicable standards, and any other safety, security, regulatory or other requirements.

These resources are subject to change without notice. TI grants you permission to use these resources only for development of an application that uses the TI products described in the resource. Other reproduction and display of these resources is prohibited. No license is granted to any other TI intellectual property right or to any third party intellectual property right. TI disclaims responsibility for, and you will fully indemnify TI and its representatives against, any claims, damages, costs, losses, and liabilities arising out of your use of these resources.

TI's products are provided subject to [TI's Terms of Sale](#) or other applicable terms available either on ti.com or provided in conjunction with such TI products. TI's provision of these resources does not expand or otherwise alter TI's applicable warranties or warranty disclaimers for TI products.

TI objects to and rejects any additional or different terms you may have proposed.

Mailing Address: Texas Instruments, Post Office Box 655303, Dallas, Texas 75265
Copyright © 2022, Texas Instruments Incorporated