

Description

The AS2376Q is a low noise ($9.5\text{nV}/\sqrt{\text{Hz}}$), low offset ($25\mu\text{V}$, maximum), operational amplifier that is precision optimized by using post-package trim. With a 5.5MHz bandwidth, the device is suitable for a wide array of filtering and control applications. The low voltage operation, low quiescent current of $950\mu\text{A}$ (maximum), and excellent PSRR makes the AS2376Q suitable for direct battery-powered applications and noise-sensitive applications with noisy low-voltage rails.

The dual AS2376Q is offered in the SO-8 and MSOP-8 package, specified for operation from -40°C to $+125^\circ\text{C}$. The device is qualified to AEC-Q100 Grade 1 with automotive-grade supporting PPAPs.

Features

- Low Noise: $9.5\text{nV}/\sqrt{\text{Hz}}$ at 1kHz
- 0.1Hz to 10Hz Noise: $0.8\mu\text{V}_{\text{PP}}$
- Quiescent Current: $760\mu\text{A}$ (typical)
- Low Offset Voltage: $5\mu\text{V}$ (typ)
- Gain Bandwidth Product: 5.5MHz
- Rail-to-Rail Input and Output
- Single-Supply Operation
- Supply Voltage: 2.2V to 5.5V
- **Totally Lead-Free & Fully RoHS Compliant (Notes 1 & 2)**
- **Halogen and Antimony Free. "Green" Device (Note 3)**
- **The AS2376Q is suitable for automotive applications requiring specific change control; this part is AEC-Q100 qualified, PPAP capable, and manufactured in IATF 16949 certified facilities.**

<https://www.diodes.com/quality/product-definitions/>

- Notes:
1. No purposely added lead. Fully EU Directive 2002/95/EC (RoHS), 2011/65/EU (RoHS 2) & 2015/863/EU (RoHS 3) compliant.
 2. See <https://www.diodes.com/quality/lead-free/> for more information about Diodes Incorporated's definitions of Halogen- and Antimony-free, "Green" and Lead-free.
 3. Halogen- and Antimony-free "Green" products are defined as those which contain $<900\text{ppm}$ bromine, $<900\text{ppm}$ chlorine ($<1500\text{ppm}$ total Br + Cl) and $<1000\text{ppm}$ antimony compounds.

Pin Assignments

TOP VIEW

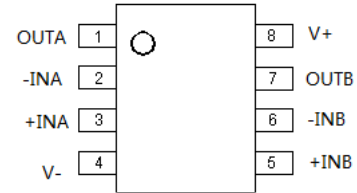

SO-8

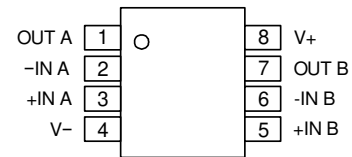

MSOP-8

Applications

- Auto pumps
- Position sensors
- Vehicle occupant detection sensors
- Airbags
- Onboard charges (OBC)
- DC-DC converters
- Battery management systems (BMS)

Typical Applications Circuit

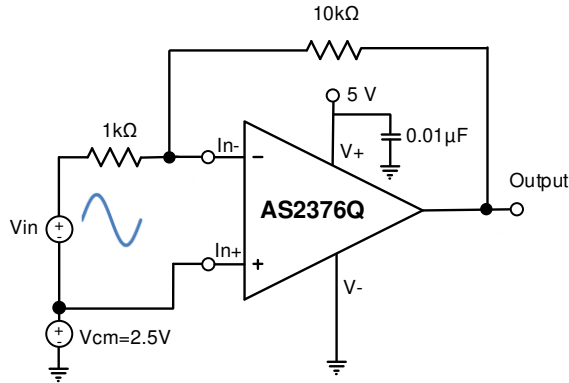

Basic Single Power Amplifier Connection

Pin Description

PIN		I/O	DESCRIPTION
NAME	SO-8/MSOP-8		
+IN A	3	I	Noninverting input, channel A
+IN B	5	I	Noninverting input, channel B
-IN A	2	I	Inverting input, channel A
-IN B	6	I	Inverting input, channel B
OUT A	1	O	Output, channel A
OUT B	7	O	Output, channel B
V+	8	—	Positive (highest) power supply
V-	4	—	Negative (lowest) power supply

Functional Block Diagram

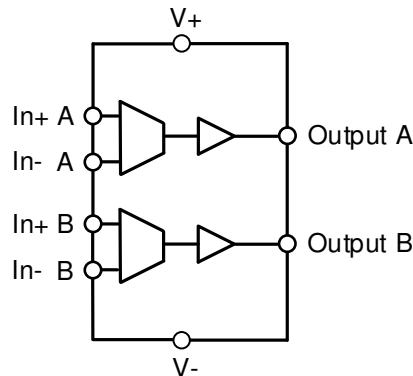

AS2376Q Functional Block

Absolute Maximum Ratings (Note 4) (@T_A = +25°C, unless otherwise specified.)

Symbol	Parameter	Rating		Unit
V ₊ -V ₋	Supply Voltage	6.5		V
-	Output Short Circuit to V ₊	(Note 5)		-
-	Output Short Circuit to V ₋	(Note 6)		-
Current	Signal input terminals (Note 7)	(Note 7)		mA
	Output short-circuit (Note 8)	Continuous		mA
T _{ST}	Storage Temperature	-65 to +150		°C
T _J	Maximum Junction Temperature	+150		°C
T _{LEAD}	Lead Temperature (Soldering, 10 Seconds)	+260		°C
R _{θJA}	Junction-to-Ambient Thermal Resistance	SO-8	115	°C/W
		MSOP-8	210	
R _{θJC}	Junction-to-Case Thermal Resistance	SO-8	18	°C/W
		MSOP-8	40	
ESD HBM	Human Body Model ESD Protection	4		kV
ESD CDM	Charged-device Model ESD Protection	1		kV

- Notes:
4. Absolute Maximum Ratings indicate limits beyond which damage to the device may occur. Operating Ratings indicate conditions for which the device is intended to be functional, but specific performance is not guaranteed. For guaranteed specifications and the test conditions, see the Electrical Characteristics.
 5. Shorting output to V₊ will adversely affect reliability.
 6. Shorting output to V₋ will adversely affect reliability.
 7. Input terminals are diode-clamped to the power-supply rails. Input signals that can swing more than 0.3V beyond the supply rails should be current limited to 10mA or less.
 8. Short-circuit to ground.

Recommended Operating Conditions

Symbol	Parameter	Min	Max	Unit
V _{CC}	Supply Voltage	2.2	5.5	V
T _A	Ambient Operating Temperature Range	-40	+125	°C

Electrical Characteristics (Limits in standard typeface are for $T_A = +25^\circ\text{C}$, **bold** typeface applies over -40°C to $+125^\circ\text{C}$ (Note 9), $R_L = 10\text{k}\Omega$ connected to $V_S / 2$, $V_{CM} = V_S / 2$, and $V_{OUT} = V_S / 2$, unless otherwise noted.)

SYMBOL	PARAMETER	TEST CONDITIONS	MIN	TYP	MAX	UNIT
OFFSET VOLTAGE						
V_{OS}	Input offset voltage (Note 10)	-	-	5	25	μV
		Long-term stability (Note 11)	-	-	60	μV
		Package level shift (Note 12)	-	-	320	μV
$\Delta V_{OS}/\Delta T$	Input offset voltage versus temperature	$T_A = -40^\circ\text{C}$ to $+85^\circ\text{C}$	-	0.26	1.2	$\mu\text{V}/^\circ\text{C}$
		$T_A = -40^\circ\text{C}$ to $+125^\circ\text{C}$	-	0.32	2	$\mu\text{V}/^\circ\text{C}$
PSRR	Input offset voltage versus power supply	$T_A = 25^\circ\text{C}$, $V_S = 2.2\text{V}$ to 5.5V , $V_{CM} < (V^+) - 1.3\text{V}$	-	5	20	$\mu\text{V}/\text{V}$
		$T_A = -40^\circ\text{C}$ to $+125^\circ\text{C}$	-	5	-	$\mu\text{V}/\text{V}$
		$V_S = 2.2\text{V}$ to 5.5V , $V_{CM} < (V^+) - 1.3\text{V}$	-	5	-	$\mu\text{V}/\text{V}$
-	Channel separation, dc		-	0.5	-	mV/V
INPUT BIAS CURRENT						
I_B	Input bias current	$T_A = 25^\circ\text{C}$	-	0.2	70	pA
		$T_A = -40^\circ\text{C}$ to $+125^\circ\text{C}$	See <i>Typical Characteristics</i>			pA
I_{OS}	Input offset current		-	0.2	70	pA
NOISE						
-	Input voltage noise	$f = 0.1\text{ Hz}$ to 10 Hz	-	0.8	-	μVPP
e_n	Input voltage noise density	$f = 1\text{ kHz}$	-	9.5	-	$\text{nV}/\sqrt{\text{Hz}}$
I_n	Input current noise	$f = 1\text{ kHz}$	-	2	-	$\text{fA}/\sqrt{\text{Hz}}$
INPUT VOLTAGE RANGE						
V_{CM}	Common-mode voltage range	-	$(V^-) - 0.1$	-	$(V^+) + 0.1$	V
CMRR	Common-mode rejection ratio	$(V^-) < V_{CM} < (V^+) - 1.3\text{V}$	76	90		dB
INPUT CAPACITANCE						
-	Differential	-	-	6.5	-	pF
-	Common-mode	-	-	13	-	pF
OPEN-LOOP GAIN						
A_{OL}	Open-loop voltage gain	$50\text{ mV} < V_O < (V^+) - 50\text{ mV}$, $R_L = 10\text{ k}\Omega$	120	134	-	dB
		$100\text{ mV} < V_O < (V^+) - 100\text{ mV}$, $R_L = 2\text{ k}\Omega$	120	126	-	dB
FREQUENCY RESPONSE $C_L = 100\text{ pF}$, $V_S = 5.5\text{ V}$						
GBW	Gain-bandwidth product	-	-	5.5	-	MHz
SR	Slew rate	$G = 1$	-	2	-	$\text{V}/\mu\text{s}$
t_s	Settling time	Settling to 0.1%, 2-V step, $G = 1$	-	1.6	-	μs
		Settling to 0.01%, 2-V step, $G = 1$	-	2	-	μs
-	Overload recovery time	$V_{IN} \times \text{gain} > V_S$	-	0.33	-	μs
-	Overload recovery time	$V_{IN} \times \text{gain} > V_S$	-	0.33	-	μs

- Notes:
- Limits over the full temperature are guaranteed by design, but not tested in production.
 - After mounted to PCB, V_{OS} value will be different to spec, the delta value depend on PCB solder stress, the max value is between $\pm 80\mu\text{V}$, per our experiment.
 - AS2376Q, the long-term stability is defined as MAX. VOS shift during life HTOL 1000 hours with $T_A = +125^\circ\text{C}$. ($T_j = 150^\circ\text{C}$) This V_{OS} drift with time is not a linear function of time, and the shift is greater initially and diminishes over time. This parameter is guaranteed by design.
 - After HTSL 2000 hours with $T_A = +150^\circ\text{C}$, the V_{OS} drift test condition is $T_A = +125^\circ\text{C}$

Electrical Characteristics (Limits in standard typeface are for $T_A = +25^\circ\text{C}$, **bold** typeface applies over -40°C to $+125^\circ\text{C}$ (Note 9), $R_L = 10\text{ k}\Omega$ connected to $V_S / 2$, $V_{CM} = V_S / 2$, and $V_{OUT} = V_S / 2$, unless otherwise noted.)

	PARAMETER	TEST CONDITIONS	MIN	TYP	MAX	UNIT
OUTPUT						
-	Voltage output swing from rail	$T_A = 25^\circ\text{C}$, $R_L = 10\text{ k}\Omega$	-	10	20	mV
		$T_A = -40^\circ\text{C}$ to $+125^\circ\text{C}$, $R_L = 10\text{ k}\Omega$	-	-	40	mV
		$T_A = 25^\circ\text{C}$, $R_L = 2\text{ k}\Omega$	-	40	50	mV
		$T_A = -40^\circ\text{C}$ to $+125^\circ\text{C}$, $R_L = 2\text{ k}\Omega$	-	-	80	mV
I_{SC}	Short-circuit current	-	-	+30, -50	-	mA
C_{LOAD}	Capacitive load drive	-	See <i>Typical Characteristics</i>			-
R_O	Open-loop output	-	-	150	-	Ω
POWER SUPPLY						
V_S	Specified voltage range	-	2.2	-	5.5	V
	Operating voltage range	-	-	2 to 5.5	-	V
I_Q	Quiescent current per amplifier	$T_A = 25^\circ\text{C}$, $I = 0$, $V = 5.5\text{ V}$, $V_{CM} < (V^+) - 1.3\text{ V}$	-	760	950	μA
		$T_A = -40^\circ\text{C}$ to $+125^\circ\text{C}$	-	-	1	mA
TEMPERATURE						
-	Specified range	-	-40	-	125	$^\circ\text{C}$
-	Operating range	-	-40	-	150	$^\circ\text{C}$

Note: 9. Limits over the full temperature are guaranteed by design, but not tested in production.

Performance Characteristics

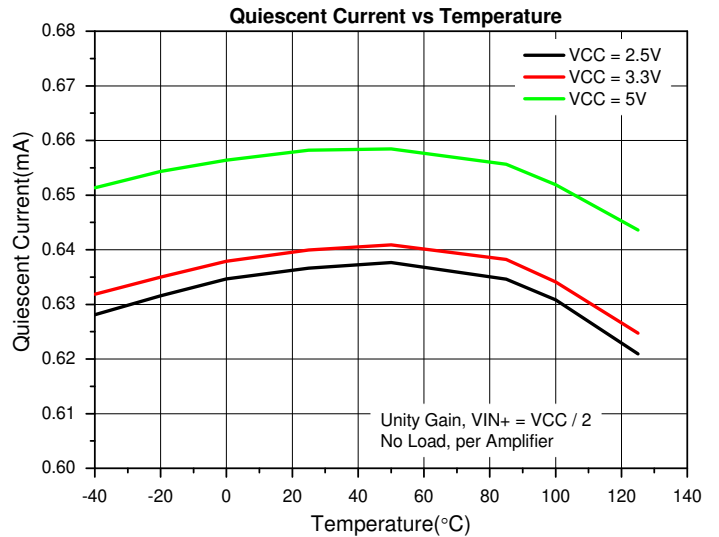
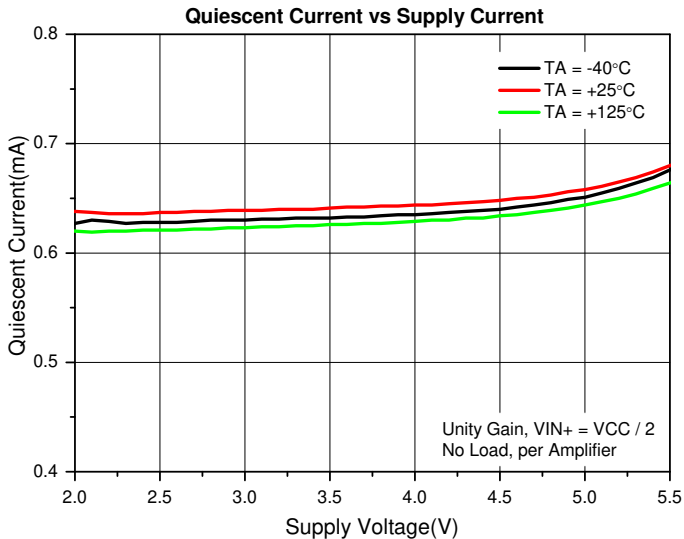
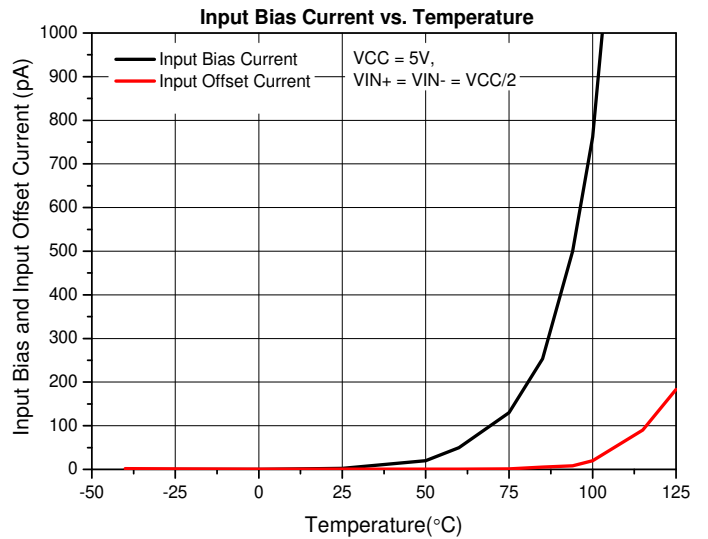
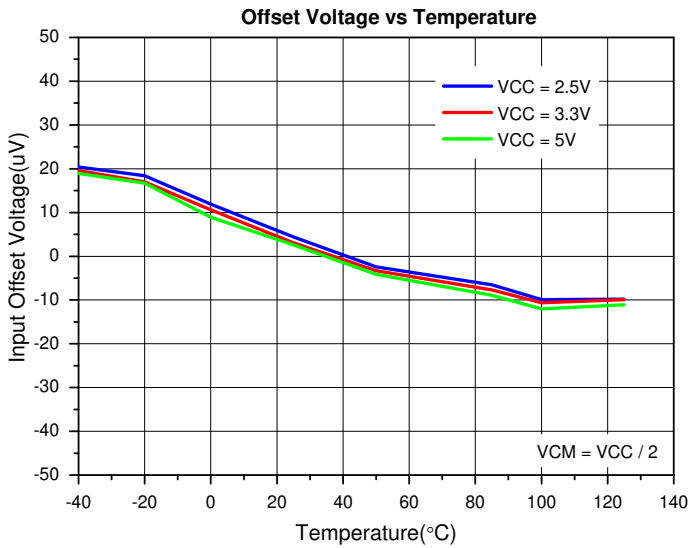
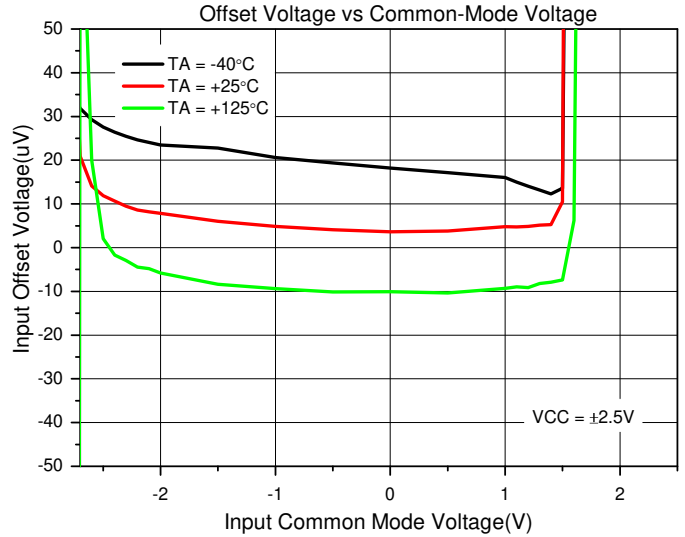
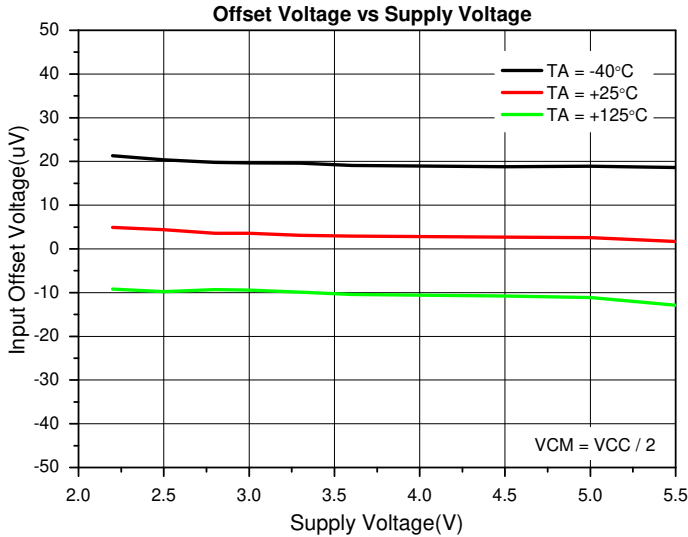

Performance Characteristics (continued)

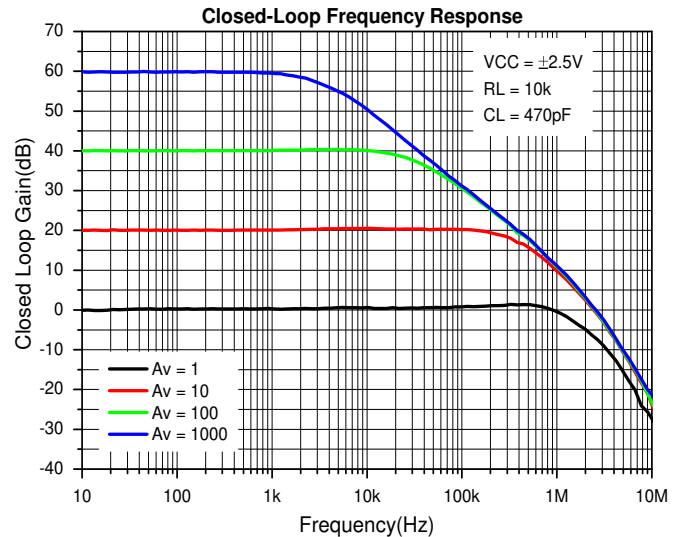
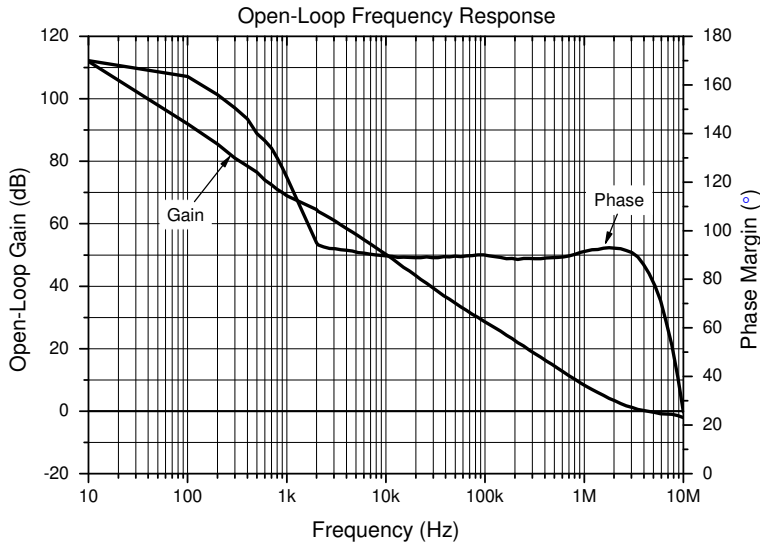
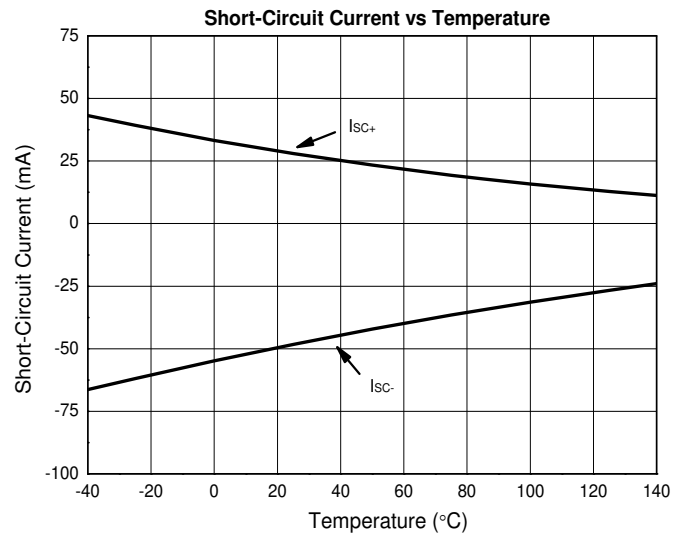
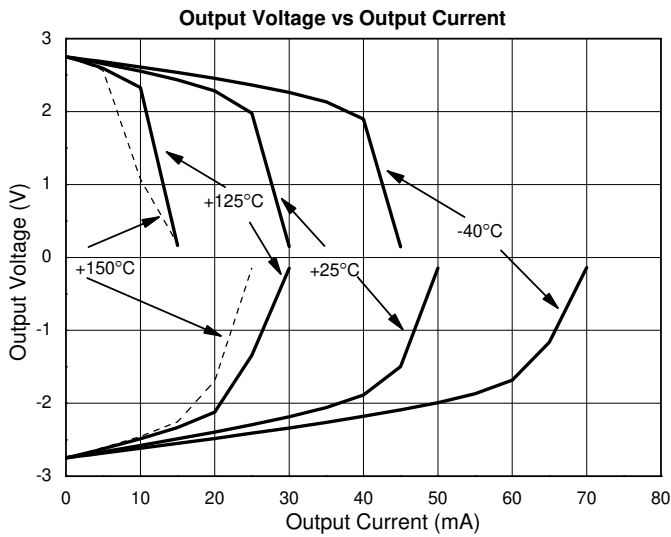
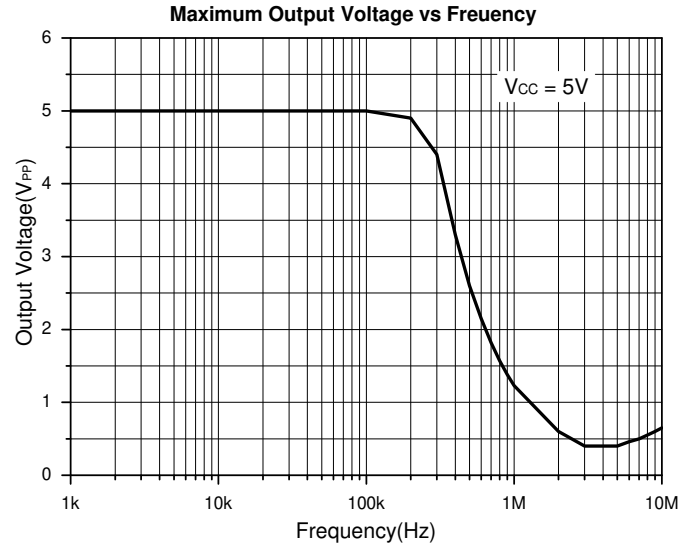
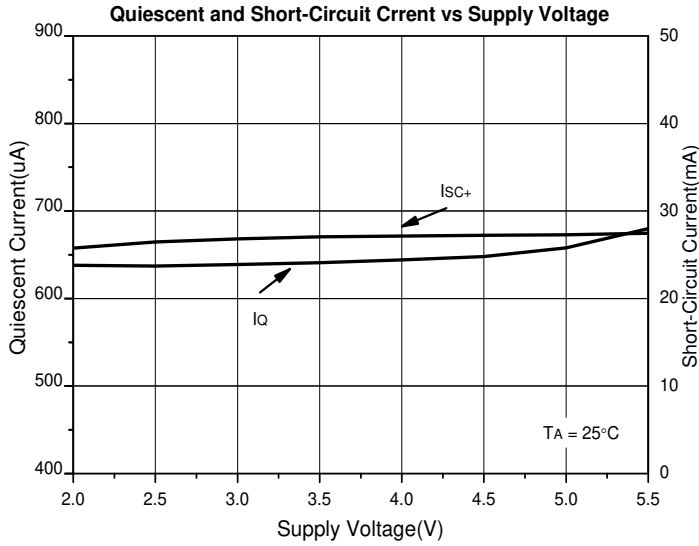

Performance Characteristics (continued)

Small-Signal Pulse Response



Large-Signal Pulse Response



Positive Input Overload Recovery

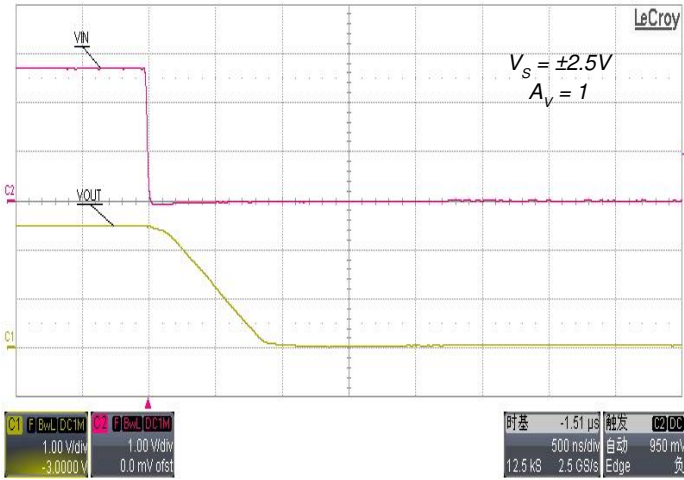

Negative Input Overload Recovery

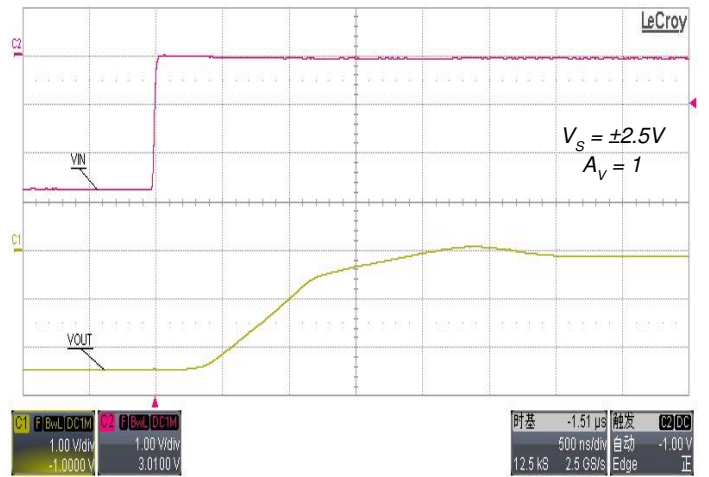

Positive Input Overload Recovery

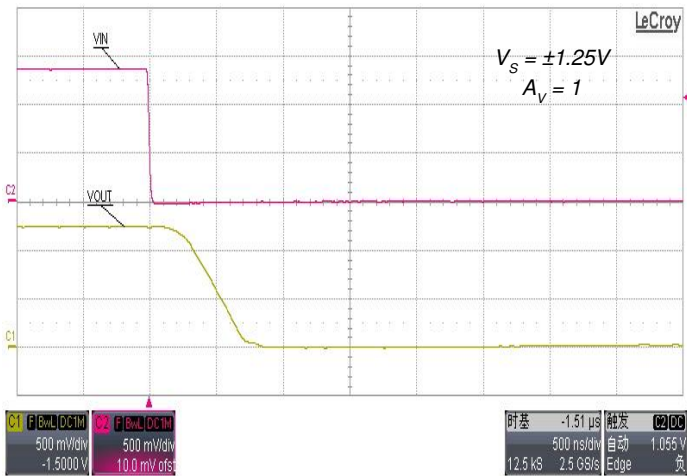

Negative Input Overload Recovery



Performance Characteristics (continued)

Positive Output Overload Recovery

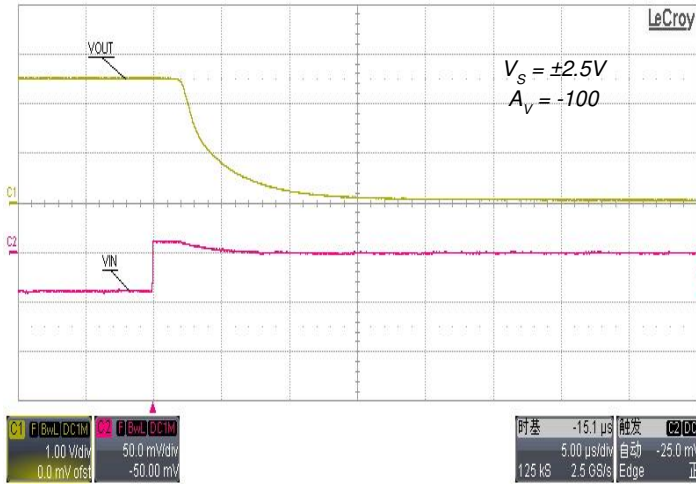

Negative Output Overload Recovery

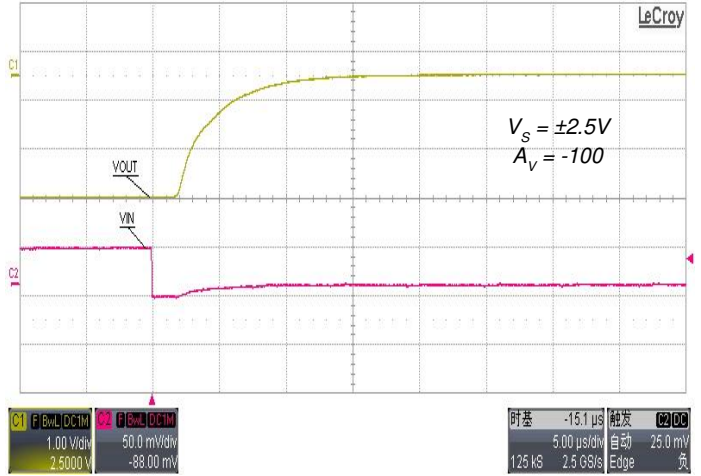

Positive Output Overload Recovery

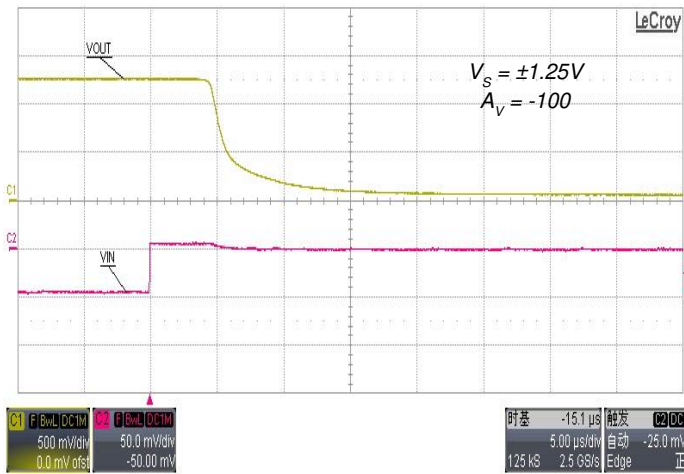

Negative Output Overload Recovery

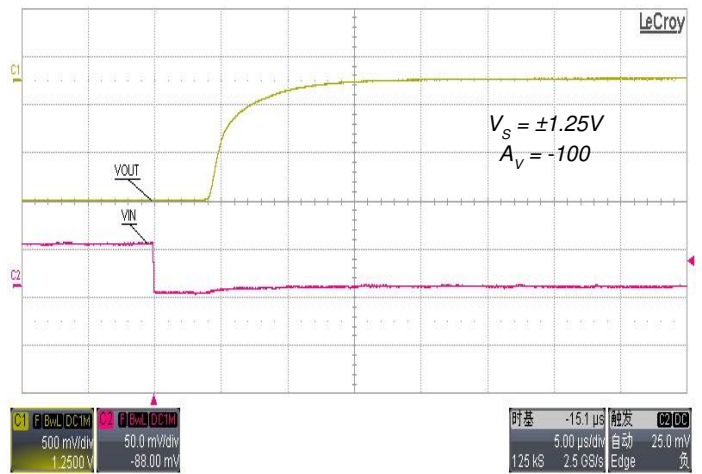

0.1-Hz to 10-Hz Input Voltage Noise

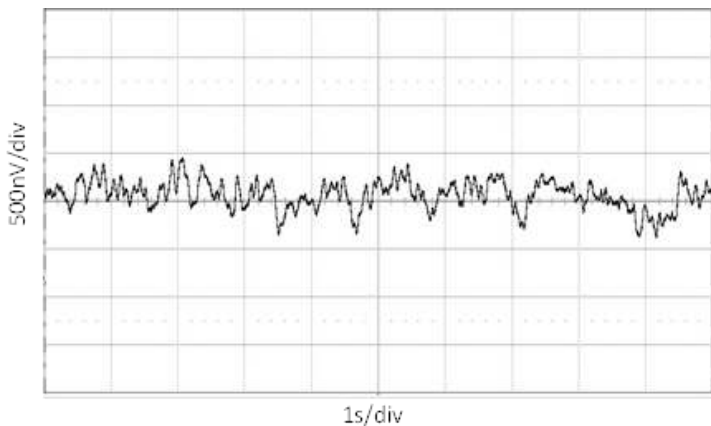

0.1-Hz to 10-Hz Input Voltage Noise

Input Voltage Noise Spectral Density

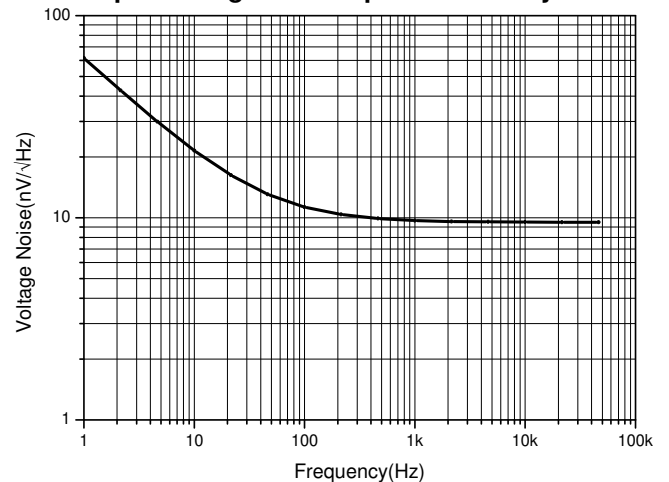

Application Information

Overview

The AS2376Q combines low offset (25 μ V, maximum) and 5.5MHz bandwidth for a wide variety of filtering and control applications. Many op amps use chopper stabilization to achieve low offset voltage but this normally comes with a restriction of bandwidth to less than 500kHz. The offset of the AS2376Q is addressed by using post package trim allowing for the retention of significant bandwidth.

Stability Considerations when Driving Capacitive Loads

Operational amplifiers are prone to oscillation when required to drive large capacitive loads. The AS2376Q is capable of driving a 250 picofarad load at unity gain. Larger loads will require the insertion of a nulling resistor (denoted as R_S) in series with the load capacitor. The suggested nulling resistor value is 10 Ω to 20 Ω . This addition will introduce a small error but is negligible in most applications.

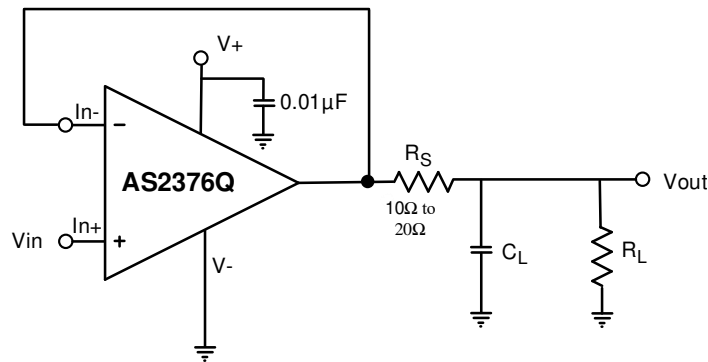

Circuit for Driving Large Capacitive Loads

Offset Voltage as Input Common Mode Approaches V+

The AS236Q has an input circuitry configuration that is common to most rail to rail input operational amplifiers. At the low end of the common mode input voltage range, the input signals are processed by a differential pair of PMOS transistors. This portion of the circuit has been precision adjusted with post package trim allowing the offset to be in the microvolts range. As the input common mode voltage approaches approximately one volt less than the positive supply, the inputs are transitioned to a second differential pair of NMOS transistors. This portion of the op amp has an offset voltage similar to a conventional op amp. As noted in the heading of the Electrical Characteristics Section, the precision offset voltage is optimized at a common mode of one half of the supply voltage. This conceptual chart depicts the approximate best case of extending the precision common mode area by using the device at 5.5V supply.

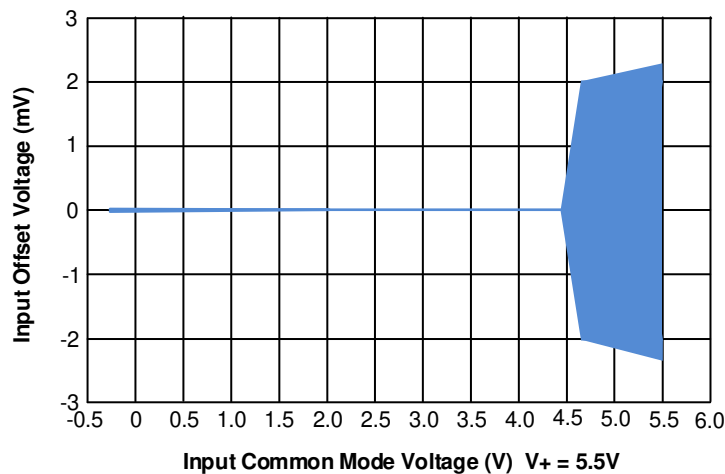

Offset Voltage over Common Mode Voltage Range

Ordering Information

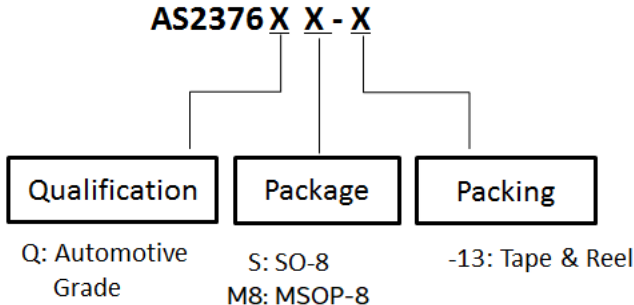

Orderable Part Number	Package Code	Package	Packing		
			Quantity	Part Number Suffix	Carrier
AS2376QS-13	S	SO-8	2,500	-13	Tape and Reel
AS2376QM8-13	M8	MSOP-8	2,500	-13	Tape and Reel

Marking Information

(Top View)

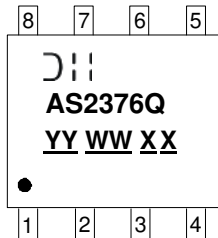

YY : Year : 19, 20, 21~
WW : Week : 01~52; 52 represents 52 and 53 week
XX : Internal Code

Orderable Part Number	Package	Identification Code
AS2376QS-13	SO-8	AS2376Q

(Top View)

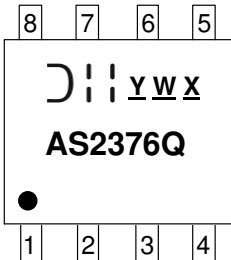

Y : Year : 0 to 9
W : Week : A to Z : 1 to 26 week;
 a to z : 27 to 52 week; z represents 52 and 53 week
X : Internal Code

Orderable Part Number	Package	Identification Code
AS2376QM8-13	MSOP-8	AS2376Q

Package Outline Dimensions

Please see <http://www.diodes.com/package-outlines.html> for the latest version.

SO-8

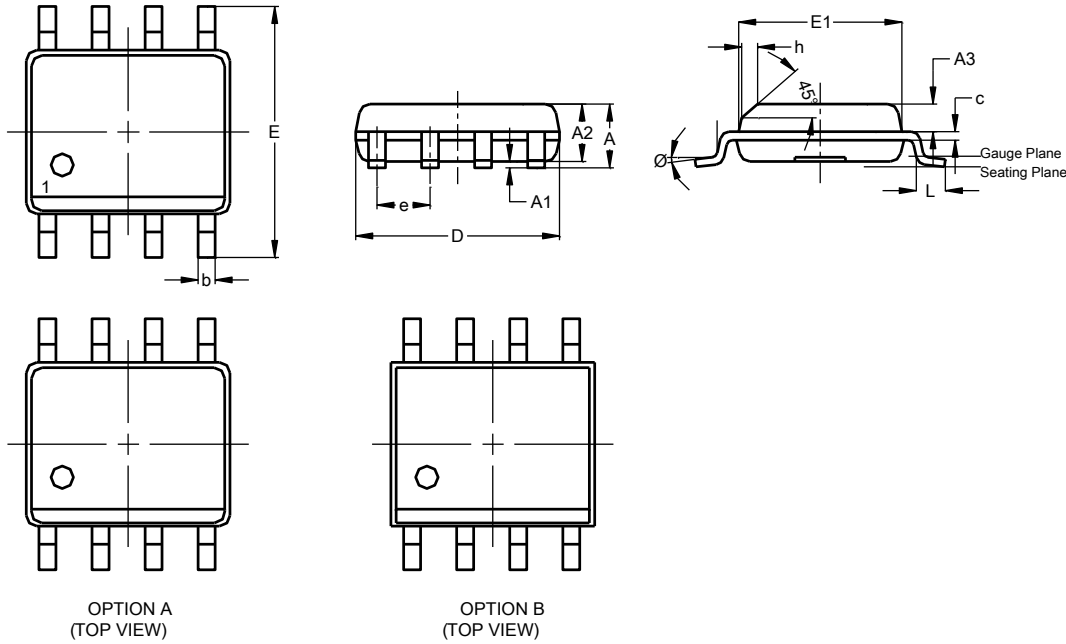

SO-8 (Standard)			
Dim	Min	Max	Typ
A	--	1.75	--
A1	0.10	0.25	--
A2	1.25	1.65	--
A3	0.50	0.70	--
b	0.30	0.51	--
c	0.15	0.25	--
D	4.80	5.00	--
E	5.80	6.20	6.00
E1	3.80	4.00	--
e	--	--	1.27
h	0.25	0.50	--
L	0.45	0.82	--
Ø	0°	8°	--
All Dimensions in mm			

MSOP-8

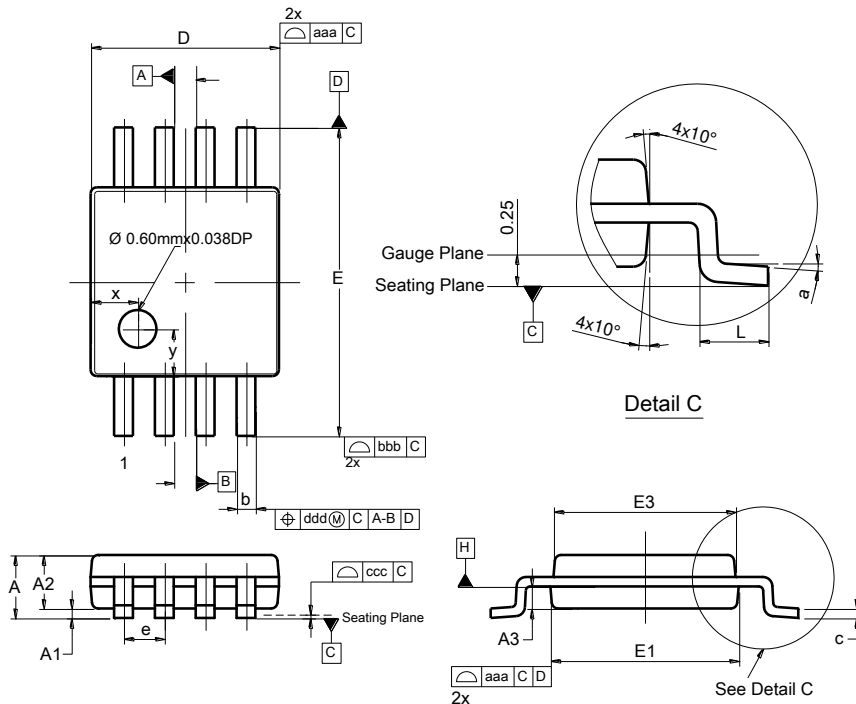

MSOP-8			
Dim	Min	Max	Typ
A	--	1.10	--
A1	0.05	0.15	0.10
A2	0.75	0.95	0.86
A3	0.29	0.49	0.39
b	0.22	0.38	0.30
c	0.08	0.23	0.15
D	2.90	3.10	3.00
E	4.70	5.10	4.90
E1	2.90	3.10	3.00
E3	2.85	3.05	2.95
e	--	--	0.65
L	0.40	0.80	0.60
a	0°	8°	4°
x	--	--	0.750
y	--	--	0.750
aaa	0.20		
bbb	0.25		
ccc	0.10		
ddd	0.13		
All Dimensions in mm			

Suggested Pad Layout

Please see <http://www.diodes.com/package-outlines.html> for the latest version.

SO-8

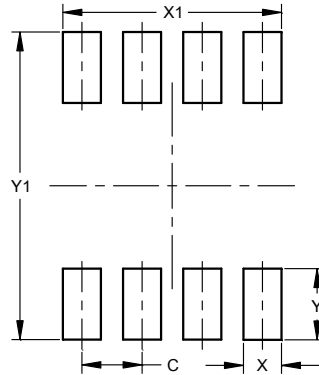

Dimensions	Value (in mm)
C	1.27
X	0.802
X1	4.612
Y	1.505
Y1	6.50

MSOP-8

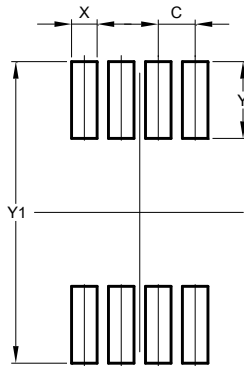

Dimensions	Value (in mm)
C	0.650
X	0.450
Y	1.350
Y1	5.300

Mechanical Data

SO-8

- Package Material: Molded Plastic, UL Flammability Rating 94V-0
- Terminals: Finish - Matte Tin Plated Leads, Solderable per MIL-STD-202, Method 208 ③
- Weight: 0.074 grams (Approximate)
- Max Soldering Temperature +260°C for 30 secs as per JEDEC J-STD-020

MSOP-8

- Package Material: Molded Plastic, UL Flammability Rating 94V-0
- Terminals: Finish - Matte Tin Plated Leads, Solderable per MIL-STD-202, Method 208 ③
- Weight: 0.035 grams (Approximate)
- Max Soldering Temperature +260°C for 30 secs as per JEDEC J-STD-020

IMPORTANT NOTICE

1. DIODES INCORPORATED (Diodes) AND ITS SUBSIDIARIES MAKE NO WARRANTY OF ANY KIND, EXPRESS OR IMPLIED, WITH REGARDS TO ANY INFORMATION CONTAINED IN THIS DOCUMENT, INCLUDING, BUT NOT LIMITED TO, THE IMPLIED WARRANTIES OF MERCHANTABILITY, FITNESS FOR A PARTICULAR PURPOSE OR NON-INFRINGEMENT OF THIRD PARTY INTELLECTUAL PROPERTY RIGHTS (AND THEIR EQUIVALENTS UNDER THE LAWS OF ANY JURISDICTION).
2. The Information contained herein is for informational purpose only and is provided only to illustrate the operation of Diodes' products described herein and application examples. Diodes does not assume any liability arising out of the application or use of this document or any product described herein. This document is intended for skilled and technically trained engineering customers and users who design with Diodes' products. Diodes' products may be used to facilitate safety-related applications; however, in all instances customers and users are responsible for (a) selecting the appropriate Diodes products for their applications, (b) evaluating the suitability of Diodes' products for their intended applications, (c) ensuring their applications, which incorporate Diodes' products, comply the applicable legal and regulatory requirements as well as safety and functional-safety related standards, and (d) ensuring they design with appropriate safeguards (including testing, validation, quality control techniques, redundancy, malfunction prevention, and appropriate treatment for aging degradation) to minimize the risks associated with their applications.
3. Diodes assumes no liability for any application-related information, support, assistance or feedback that may be provided by Diodes from time to time. Any customer or user of this document or products described herein will assume all risks and liabilities associated with such use, and will hold Diodes and all companies whose products are represented herein or on Diodes' websites, harmless against all damages and liabilities.
4. Products described herein may be covered by one or more United States, international or foreign patents and pending patent applications. Product names and markings noted herein may also be covered by one or more United States, international or foreign trademarks and trademark applications. Diodes does not convey any license under any of its intellectual property rights or the rights of any third parties (including third parties whose products and services may be described in this document or on Diodes' website) under this document.
5. Diodes' products are provided subject to Diodes' Standard Terms and Conditions of Sale (<https://www.diodes.com/about/company/terms-and-conditions/terms-and-conditions-of-sales/>) or other applicable terms. This document does not alter or expand the applicable warranties provided by Diodes. Diodes does not warrant or accept any liability whatsoever in respect of any products purchased through unauthorized sales channel.
6. Diodes' products and technology may not be used for or incorporated into any products or systems whose manufacture, use or sale is prohibited under any applicable laws and regulations. Should customers or users use Diodes' products in contravention of any applicable laws or regulations, or for any unintended or unauthorized application, customers and users will (a) be solely responsible for any damages, losses or penalties arising in connection therewith or as a result thereof, and (b) indemnify and hold Diodes and its representatives and agents harmless against any and all claims, damages, expenses, and attorney fees arising out of, directly or indirectly, any claim relating to any noncompliance with the applicable laws and regulations, as well as any unintended or unauthorized application.
7. While efforts have been made to ensure the information contained in this document is accurate, complete and current, it may contain technical inaccuracies, omissions and typographical errors. Diodes does not warrant that information contained in this document is error-free and Diodes is under no obligation to update or otherwise correct this information. Notwithstanding the foregoing, Diodes reserves the right to make modifications, enhancements, improvements, corrections or other changes without further notice to this document and any product described herein. This document is written in English but may be translated into multiple languages for reference. Only the English version of this document is the final and determinative format released by Diodes.
8. Any unauthorized copying, modification, distribution, transmission, display or other use of this document (or any portion hereof) is prohibited. Diodes assumes no responsibility for any losses incurred by the customers or users or any third parties arising from any such unauthorized use.
9. This Notice may be periodically updated with the most recent version available at <https://www.diodes.com/about/company/terms-and-conditions/important-notice>

The Diodes logo is a registered trademark of Diodes Incorporated in the United States and other countries.
All other trademarks are the property of their respective owners.
© 2023 Diodes Incorporated. All Rights Reserved.

www.diodes.com