

PIC32 USB Digital Audio Accessory Board Information Sheet

Features

The PIC32 USB Digital Audio Accessory Board showcases a 16/24-bit quality digital stereo audio development platform using the PIC32 microcontroller (MCU). It can be used for 16/24-bit stereo audio playback and recording with a sample rate of up to 48 kHz. This accessory board is powered by the USB Host and can be used with any personal computer (PC), tablet, gaming station, or mobile device that supports the USB Audio Device Class. The digital audio stream is transferred over USB isochronous transfers. The PIC32 USB Digital Audio Accessory Board features the PIC32 MCU, which has a USB module with Host and Device capability, in addition to an SPI peripheral module with Audio Mode that supports I²S, LJ, RJ, DSP/PCM modes and an accurate, flexible audio reference clock output generation module that can be used as time base for the external codec or Digital-to-Analog Converter (DAC).

Key features of the PIC32 USB Digital Audio Accessory Board:

- PIC32MX250F128B MCU: 40 MIPS, 128 KB of program memory and 32 KB of RAM
- PIC32 I²S support (LJ, RJ, DSP/PCM modes supported) – all modes can be 16/24-bit
- PIC32 reference clock output for codec master clock
- Audio codec (AK4645A) with up to 48 kHz sampling rate and 16/24-bit resolution
- Supported codec-based audio processing features:
 - 5-band equalizer
 - Analog output mixing
 - Stereo separation emphasis and wind-noise filtering
 - Auto-level control

FIGURE 1: PIC32 USB DIGITAL AUDIO ACCESSORY BOARD



Getting Started

The PIC32 USB Digital Audio Accessory Board is preprogrammed with a USB Audio Headset application, which demonstrates audio playback and record. This demonstration can playback high quality stereo audio through headphones. It can also record audio through a microphone.

To run the demonstration, follow these steps:

1. Using the USB cable provided with the board, insert the mini-B connector end of the cable into the receptacle labeled J1 on the PIC32 USB Digital Audio Accessory Board.
2. Connect the other end of the cable to the USB port of the PC.
3. Wait for the USB audio driver to be automatically installed and the PIC32 USB Digital Audio Accessory Board to be enumerated as a digital audio device.
4. Audio Playback:
 - a) Plug in a pair of headphones to the connector labeled HP OUT.
 - b) Open any music application on the PC and play music.
 - c) Listen to the music through a pair of headphones.
5. Audio Recording:
 - a) Plug in a microphone to either the MIC1 IN or MIC2 IN connector.
 - b) Open any audio record application on the PC and begin recording.
 - c) After recording for the desired duration, save and playback the recorded audio.

To get started with development, please visit www.microchip.com/pic32tools, and click the PIC32 USB Digital Audio Accessory Board product link.

Americas

Atlanta - 678-957-9614
Boston - 774-760-0087
Chicago - 630-285-0071
Cleveland - 216-447-0464
Dallas - 972-818-7423
Detroit - 248-538-2250
Indianapolis - 317-773-8323
Los Angeles - 949-462-9523
Phoenix - 480-792-7200
Santa Clara - 408-961-6444
Toronto - 905-673-0699

Europe

Austria - Wels - 43-7242-2244-39
Denmark - Copenhagen - 45-4450-2828
France - Paris - 33-1-69-53-63-20
Germany - Munich - 49-89-627-144-0
Italy - Milan - 39-0331-742611
Netherlands - Drunen - 31-416-690399
Spain - Madrid - 34-91-708-08-90
UK - Wokingham - 44-118-921-5869

Asia/Pacific

Australia - Sydney - 61-2-9868-6733
China - Beijing - 86-10-8569-2100
China - Chengdu - 86-28-8665-5511
China - Chongqing - 86-23-8980-9588

Asia/Pacific (Continued)

China - Hangzhou - 86-571-2819-3187
China - Hong Kong SAR - 852-2401-1200
China - Nanjing - 86-25-8473-2460
China - Qingdao - 86-532-8502-7355
China - Shanghai - 86-21-5407-5533
China - Shenyang - 86-24-2334-2829
China - Shenzhen - 86-755-8203-2660
China - Wuhan - 86-27-5980-5300
China - Xiamen - 86-592-2388138
China - Xian - 86-29-8833-7252
China - Zhuhai - 86-756-3210040
India - Bangalore - 91-80-3090-4444
India - New Delhi - 91-11-4160-8631
India - Pune - 91-20-2566-1512
Japan - Osaka - 81-66-152-7160
Japan - Yokohama - 81-45-471-6166
Korea - Daegu - 82-53-744-4301
Korea - Seoul - 82-2-554-7200
Malaysia - Kuala Lumpur - 60-3-6201-9857
Malaysia - Penang - 60-4-227-8870
Philippines - Manila - 63-2-634-9065
Singapore - 65-6334-8870
Taiwan - Hsin Chu - 886-3-5778-366
Taiwan - Kaohsiung - 886-7-536-4818
Taiwan - Taipei - 886-2-2500-6610
Thailand - Bangkok - 66-2-694-1351

11/29/11



MICROCHIP

Microchip Technology Inc. • 2355 West Chandler Blvd. • Chandler, AZ 85224-6199

www.microchip.com

The Microchip name and logo, the Microchip logo, and MPLAB are registered trademarks of Microchip Technology Incorporated in the U.S.A. and other countries. All other trademarks mentioned herein are property of their respective companies. © 2012, Microchip Technology Incorporated, Printed in the U.S.A. All Rights Reserved. 11/11

DS52061A



PIC32 USB Digital Audio Accessory Board Information Sheet

Schematics (Sheets 1 of 2)

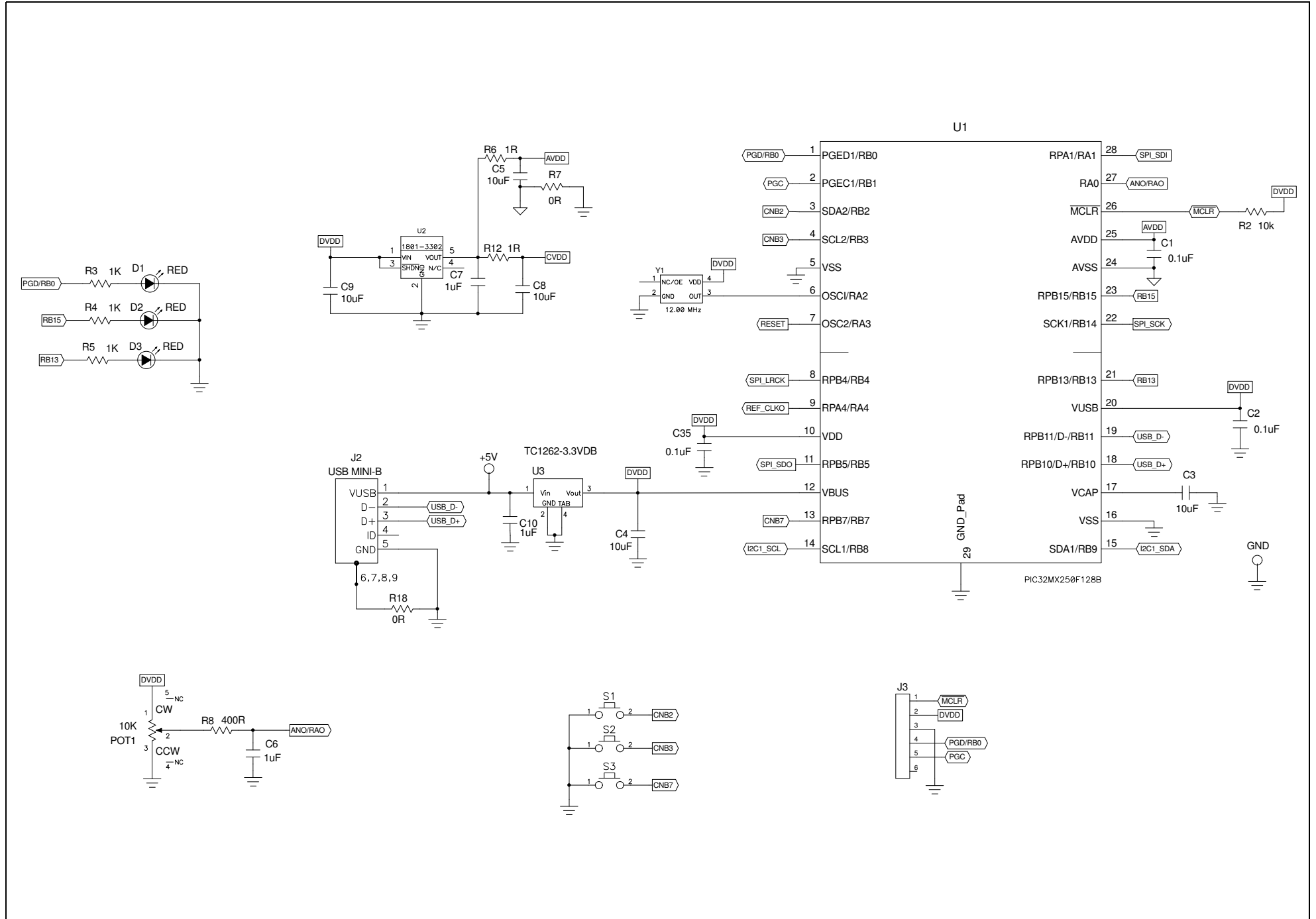

PIC32 USB Digital Audio Accessory Board Information Sheet

Schematics (Sheets 2 of 2)

