

NO. OF CKTS	PART NO.	ENG. NO.	DIMN. A	DIMN. B
2	26-23-2021	AE-3192- 2A(501)	(3.96)/.156	(7.92)/.312
3	-2031	- 3A(501)	(7.92)/.312	(11.89)/.468
4	-2041	- 4A(501)	(11.89)/.468	(15.85)/.624
5	-2051	- 5A(501)	(15.85)/.624	(19.81)/.780
6	-2061	- 6A(501)	(19.81)/.780	(23.77)/.936
7	-2071	- 7A(501)	(23.77)/.936	(27.74)/1.092
8	-2081	- 8A(501)	(27.74)/1.092	(31.70)/1.248
9	-2091	- 9A(501)	(31.70)/1.248	(35.66)/1.404
10	-2101	-10A(501)	(35.66)/1.404	(39.62)/1.560
11	-2111	-11A(501)	(39.62)/1.560	(43.59)/1.716
12	-2121	-12A(501)	(43.59)/1.716	(47.55)/1.872
13	-2131	-13A(501)	(47.55)/1.872	(51.51)/2.028
14	-2141	-14A(501)	(51.51)/2.028	(55.47)/2.184
15	-2151	-15A(501)	(55.47)/2.184	(59.44)/2.340
16	-2161	-16A(501)	(59.44)/2.340	(63.40)/2.496
17	-2171	-17A(501)	(63.40)/2.496	(67.36)/2.652
18	26-23-2181	AE-3192-18A(501)	(67.36)/2.652	(71.32)/2.808

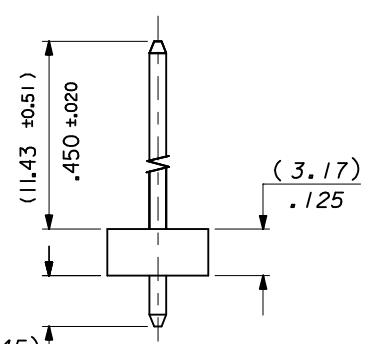
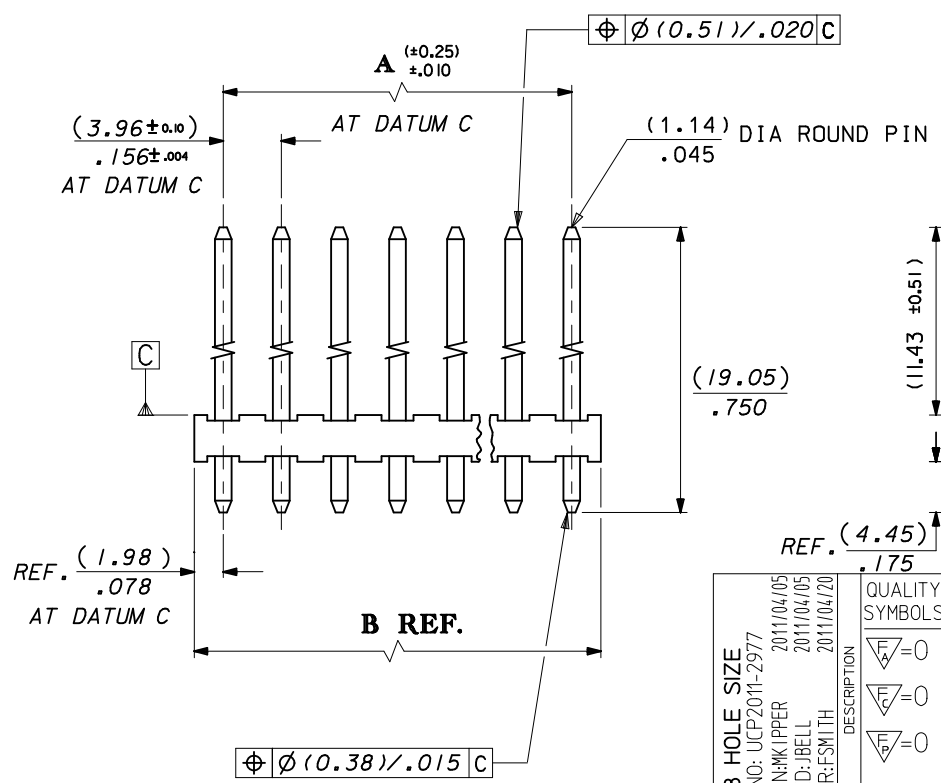
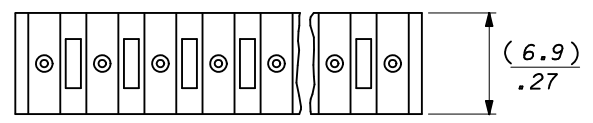
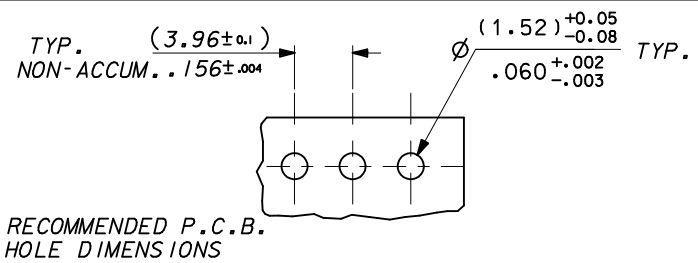

- NOTES:
1. MATERIAL: HOUSING: NYLON, UL94V-2, COLOR: NATURAL
PINS: BRASS
 2. FINISH: OVERALL GOLD: (0.00051)/.000020 MIN. OVER
(0.00076)/.000030 MIN. NICKEL
 3. PRODUCT SPECIFICATION: PS-99020-0087
 4. PACKAGING SPECIFICATION: PER PK-3192-001
 5. THIS PART CONFORMS TO CLASS B REQUIREMENTS OF
COSMETIC SPECIFICATION PS-45499-002.
 6. PIN PUSHOUT FORCE 13.3N / 3 LBS MIN.
 7. PIN MUST CONFORM TO MOLEX SOLDERABILITY SPEC
SMES-152 AFTER PLATING.
 8. RECOMMENDED PCB BOARD THICKNESS: 1.6MM.

PCB HOLE SIZE EC NO: UCP2011-2977 DRAWN: HK IPPER 2011/04/05 CHKD: BELL 2011/04/05 APPR: F SMITH 2011/04/20	QUALITY SYMBOLS ▽/0 ▽/0 ▽/0	GENERAL TOLERANCES (UNLESS SPECIFIED)	DIMENSION STYLE	SCALE	DESIGN UNITS	THIRD ANGLE PROJECTION
		mm INCH	MM/IN	3:1	METRIC	
REV	DESCRIPTION	4 PLACES ± --- ± ---	DRAWN BY	DATE	TITLE	MOLEX MOLEX INCORPORATED
		3 PLACES ± --- ± .010	NPC	1986/11/13	WAFER ASSY. KK, (3.96)/.156 CENTRES DIA. (1.14)/.045 PINS	
		2 PLACES ± 0.25 ± .015	CHECKED BY	DATE		
		1 PLACE ± 0.35 ± ---	APPROVED BY	DATE		
		ANGULAR ± ---°	MATERIAL NO.	DOCUMENT NO.	SHEET NO.	
		DRAFT WHERE APPLICABLE MUST REMAIN WITHIN DIMENSIONS	SEE CHART	SDAE-3192-NA-501	1 OF 1	
			SIZE B	THIS DRAWING CONTAINS INFORMATION THAT IS PROPRIETARY TO MOLEX INCORPORATED AND SHOULD NOT BE USED WITHOUT WRITTEN PERMISSION		