



a  MICROCHIP company

# LE792388

## Next Generation Carrier Chipset (NGCC) Octal SLAC (Codec)

The Le792388 Next Generation Octal Subscriber Line Audio processing Circuit (SLAC) device, in combination with the Le79271 SLIC device, implements a DSL friendly, high density eight-channel universal telephone line interface. This enables the design of a low cost, high performance, fully software programmable line interface with worldwide applicability. All AC, DC, and signaling parameters are programmable via a microprocessor interface. The Le792388 has an integrated test tool box and uses VCP test primitives and host routine capabilities to resolve faults to the line or line circuit.

### Detailed Block Diagram

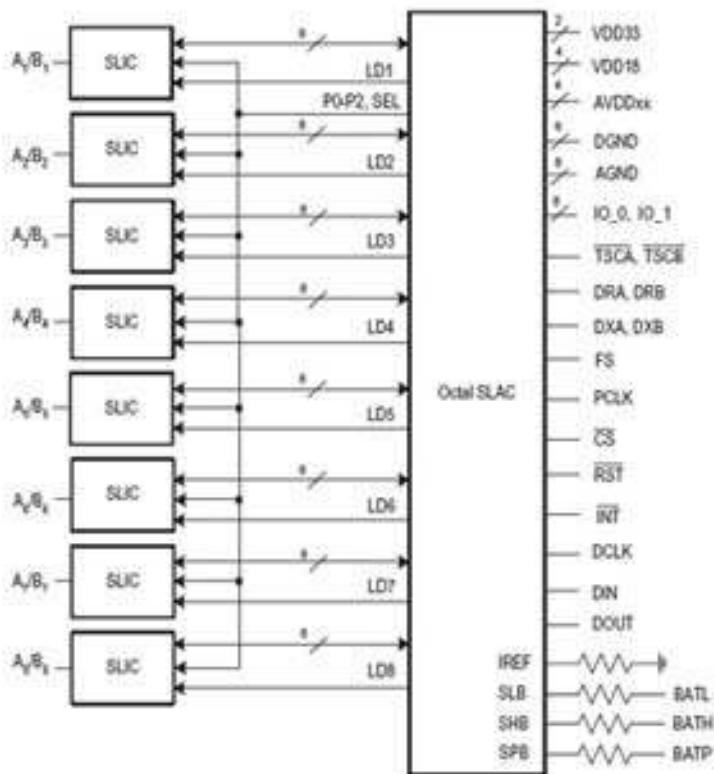

## ***Features & Benefits***

- Optimized for Next Generation Broadband xDSL and triple play applications
- Eliminates transients that could cause CRC errors
- Best-in-class GR-844 equivalent testing capability
- Ideal for high density, medium and large line count applications
- API-compatible with VE790 Series designs
- High performance digital signal processor provides programmable control of all major line card functions
  - A-law/ $\mu$ -law and linear codec/filter
  - Transmit and receive gain, Two-wire AC impedance, Transhybrid balance, Equalization
  - DC loop feeding
  - Loop supervision
  - Internal ringing generation and integrated ring-trip detection
  - Metering generation at 12 kHz and 16 kHz
    - Envelope shaping and level control
- Enhanced line control and line-test support
  - DTMF and Modem Tone Detection
  - GR-909 and GR-844 Line and circuit testing capability
  - Tone generation (DTMF, FSK, and arbitrary tone)
- Standard PCM and MPI digital interfaces
- General purpose I/O pins, can be used as relay drivers
- Features with Le79124 NGVCP
  - 72 channel call aggregation
  - GR-844 equivalent line testing