

LCD-MID-FTB

Mid-Size Flat Panel Flush Mount W/ Tilt

Product Features:

Holds most 27" – 42" flat panels

Maximum flat panel hole pattern - 410mm x 340mm

Distance from wall to back of the panel – 2.4"

Has adjustable -5° to +15° tilt

Accommodates double gang box

Load capacity – 100 lbs

Black powder coat finish

Also available in silver finish (LCD-MID-FT)

Product Specifications:

(for Architects & Engineers)

The wall flush mount for the mid-size flat panel display shall be the Video Mount Products (VMP) model LCD-MID-FT. The mount shall be designed to attach to 2 studs up to 16" apart or other suitable support surface. The mount shall be primarily constructed of formed steel and shall include spot welds. The mount shall be a universal style mount capable of adjusting to the dimensions of a variety of popular 27" to 42" flat panel displays and not necessarily be model specific. The adjustable mounting brackets shall be able to accommodate a maximum hole pattern of 410mm left to right and 340mm vertically. The mount shall be capable allowing a tilt ranging from -5° to +15°. The load capacity shall be 100 lbs.

Video Mount Products

345 Log Canoe Circle

Stevensville, MD 21666

Toll Free: 877.281.2169

Telephone: 410.643.6390

Facsimile: 410.643.6615

www.videomount.com

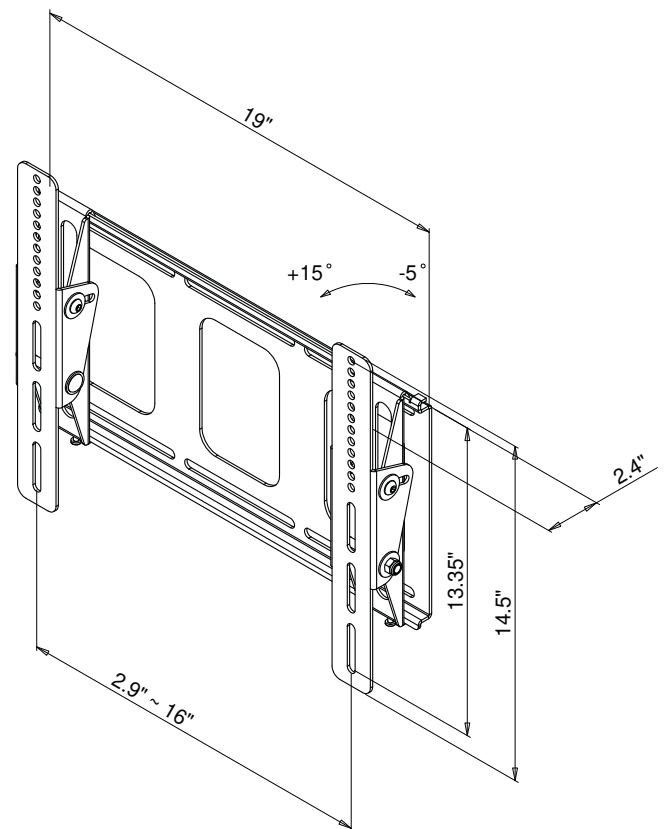

VMP
VIDEO MOUNT PRODUCTS