

# Top Load Socket: 22-9159-100

## General Description



The 9159 series of Board-to-Board interconnect system allows two PCB's to be mated end-to-end creating strips of LED lighting. Designed specifically for the unique Solid State Lighting (SSL) market requiring coplanar (horizontal-to-horizontal) PCB mating with a 5 Amp current rating in the smallest package available. The top loading socket allows complete PCB's to be replaced in the field without having to disassemble the entire strip of boards. The connector has a two part insulator whereby the top of the connector will slide open allowing the plug connector to be pulled out either vertically or at a slight angle. Once the PCB is replaced, the cover is slid back like a Zero Insertion Force (ZIF) connector to the closed position. The PCB layout is identical to the standard horizontal socket to maintain family commonality at the PCB level.

### APPLICATIONS

- Coplanar PCB mating in SSL products
- LED linear lighting strips
- Application Notes: refer to 201-01-123
- Product Specification: refer to 201-01-119

### FEATURES AND BENEFITS

- Slide open top: allows field reparability at the light fixture level
- Mates with standard horizontal or cabled plug: no need to change any connectors
- 5 Amp current rating: exceeds general market needs
- Gold plated BeCu spring contacts: reliability for harsh environments
- Available in white: supports SSL market preferences

### ELECTRICAL

- Current Rating: 5 Amps / Contact
- VAC (RMS) or DC Equivalent

### ENVIRONMENTAL

- Operating Temperature: -40°C to +125°C
- Storage Temperature: -40°C to +70°C

### MECHANICAL

- Insulator Material: Nylon: VL94V0
- Contact Material: BeCu / Phos Bronze
- Plating: Gold / Tin over Nickel
- Durability: 10 Cycles

### HOW TO ORDER

**22**  
Prefix  
Socket  
Top Loading

**9159**  
Series

**00X**  
Number of Ways

| Code | No of Ways | Details |
|------|------------|---------|
| 002  | 2          | Page 45 |
| 003  | 3          | Page 46 |
| 004  | 4          | Page 47 |
| 005  | 5          | Page 48 |
| 006  | 6          | Page 49 |

**1**  
2 Part  
PCB Strip  
Connector

**01**  
Connector  
Pitch  
01 = 3mm

**9**  
Color/Approval

| Code | Color | Approval    |
|------|-------|-------------|
| 9    | White | UL Approved |

**16**  
Plating Option

| Code | Contact                                     | Bracket         |
|------|---|-----------------|
| 16   | Gold in Contact Area<br>Gold on Solder Tail | Tin<br>all over |

Safety Standards: UL 1977-File #E90723, CSA C22.2 NO. 182.3



# Top Load Socket: 22-9159-100

## 2 Position



### SOCKET TOP LOADING 2 WAY 2 PART PCB STRIP CONNECTOR

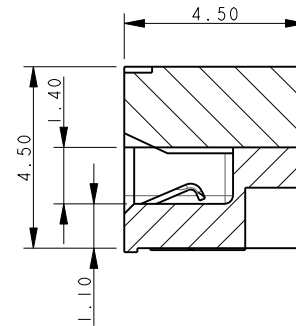
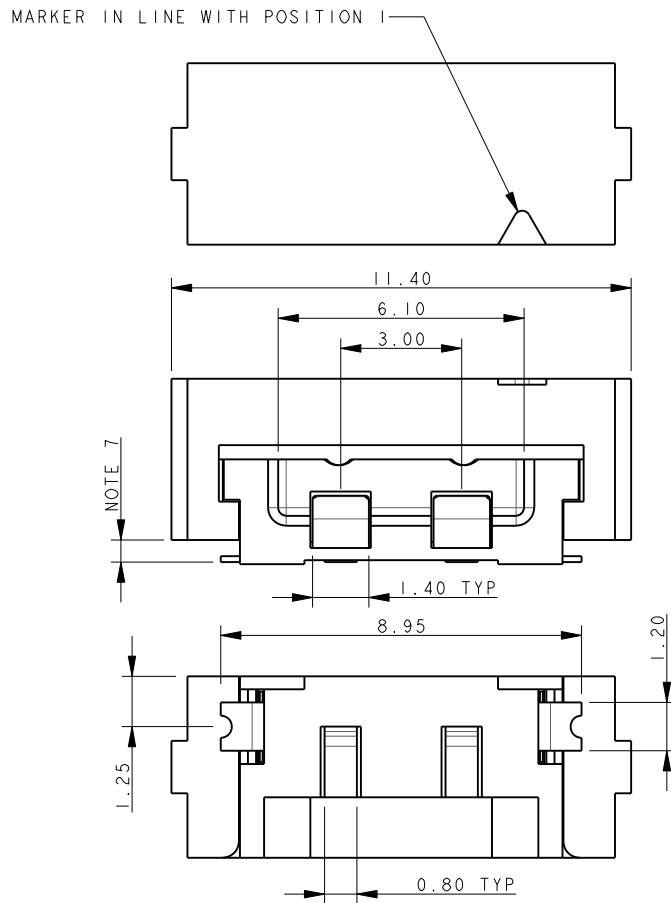

#### NOTES:

1. FOR MORE INFORMATION REFER TO PRODUCT SPEC 201-01-119.
2. DIMENSIONS ARE REFERENCE DIMENSIONS UNLESS TOLERANCES.
3. INSULATOR MATERIAL: NYLON 46. COLOR REFER TO PAGE 44.
4. CONTACT MATERIAL: COPPER ALLOY, GOLD OVER NICKEL.
5. BRACKETS: COPPER ALLOY, TIN PLATED.
6. OUTLINE OF CONNECTOR.
7. RESTRICTED COMPONENT HEIGHT UNDER CATCH, 2.20MM MAXIMUM.
8. RESTRICTED COMPONENT HEIGHT UNDER CATCH, 0.40MM MAXIMUM.
9. PACKING TAPE AND REEL, QUANTITY 1400 PER REEL.

### 2 WAY PCB BOARD LAYOUT

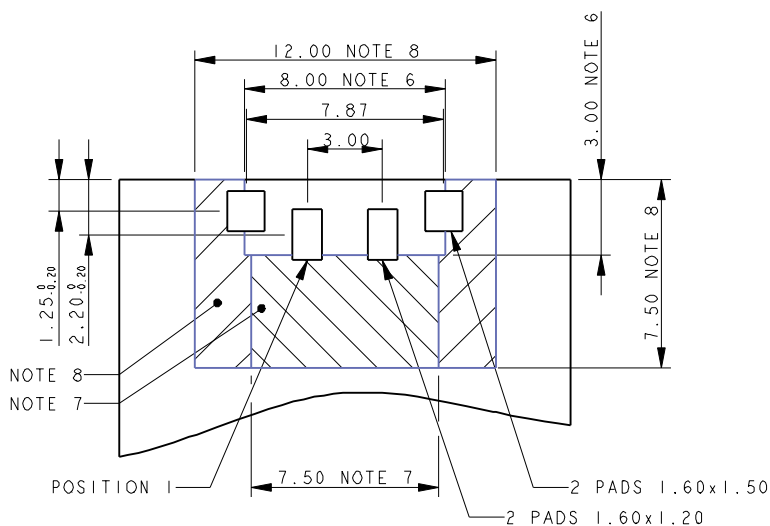

### PACKING DETAILS

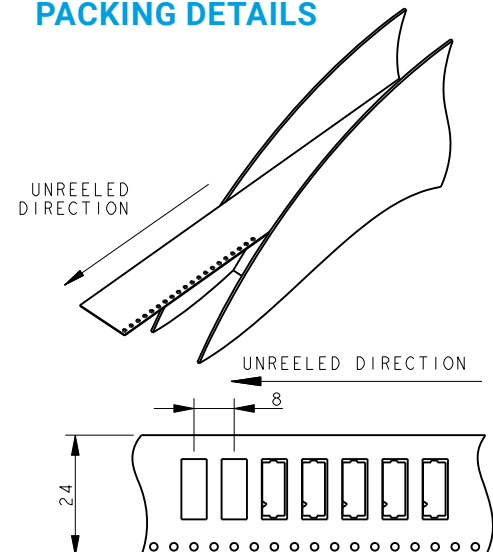

The Important Information/Disclaimer is incorporated in the catalog where these specifications came from or available online at [www.kyocera-avx.com/disclaimer/](http://www.kyocera-avx.com/disclaimer/) by reference and should be reviewed in full before placing any order.

### SOCKET TOP LOADING 3 WAY 2 PART PCB STRIP CONNECTOR

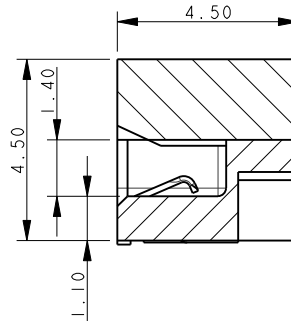
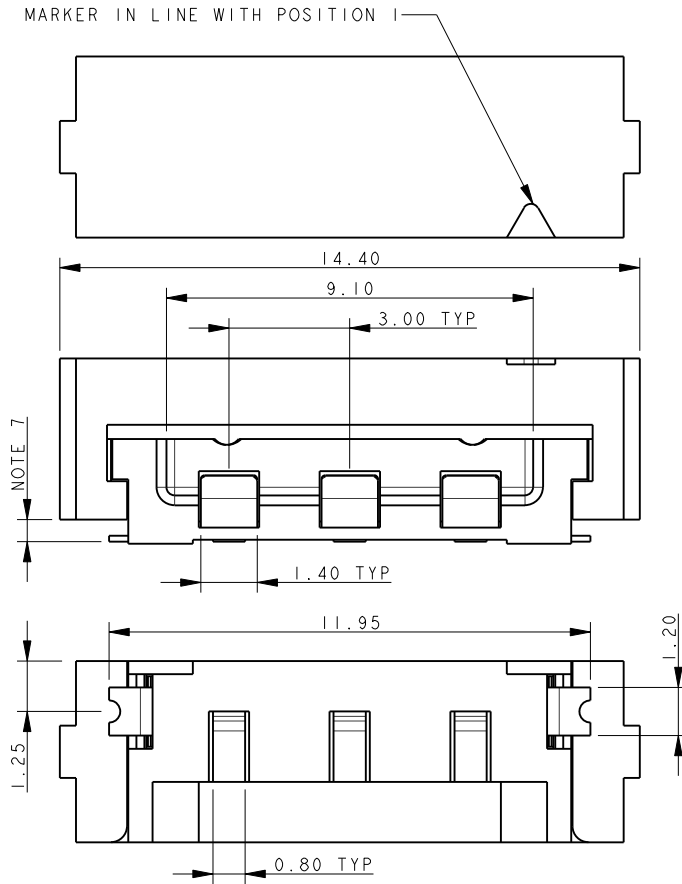

**NOTES:**

1. FOR MORE INFORMATION REFER TO PRODUCT SPEC 201-01-119.
2. DIMENSIONS ARE REFERENCE DIMENSIONS UNLESS TOLERANCES.
3. INSULATOR MATERIAL: NYLON 46. COLOR REFER TO PAGE 44.
4. CONTACT MATERIAL: COPPER ALLOY, GOLD OVER NICKEL.
5. BRACKETS: COPPER ALLOY, TIN PLATED.
6. OUTLINE OF CONNECTOR.
7. RESTRICTED COMPONENT HEIGHT UNDER CATCH, 2.20MM MAXIMUM.
8. RESTRICTED COMPONENT HEIGHT UNDER CATCH, 0.40MM MAXIMUM.
9. PACKING TAPE AND REEL, QUANTITY 1400 PER REEL.

### 3 WAY PCB BOARD LAYOUT

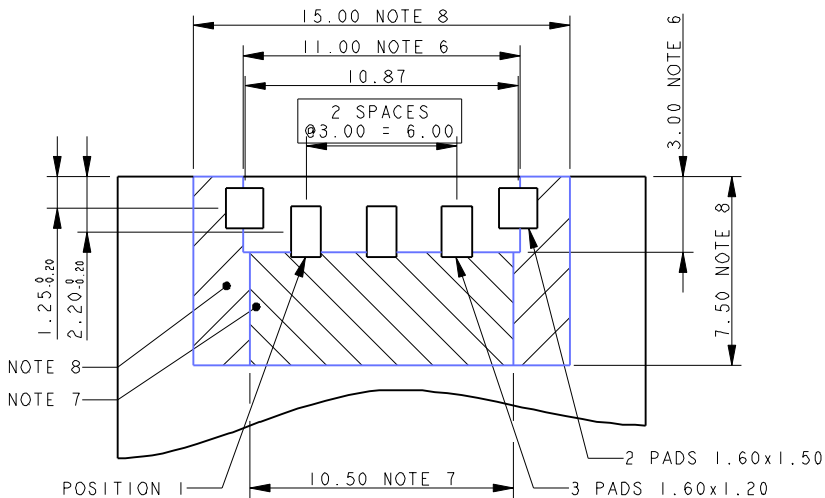

### PACKING DETAILS

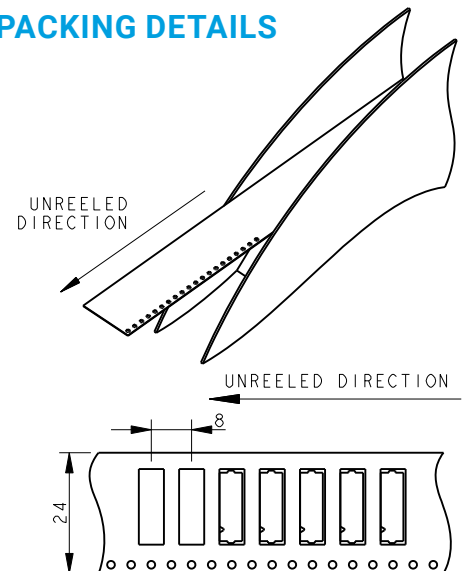

### SOCKET TOP LOADING 4 WAY 2 PART PCB STRIP CONNECTOR

I

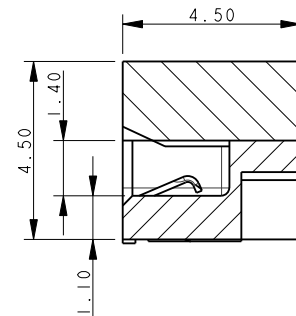
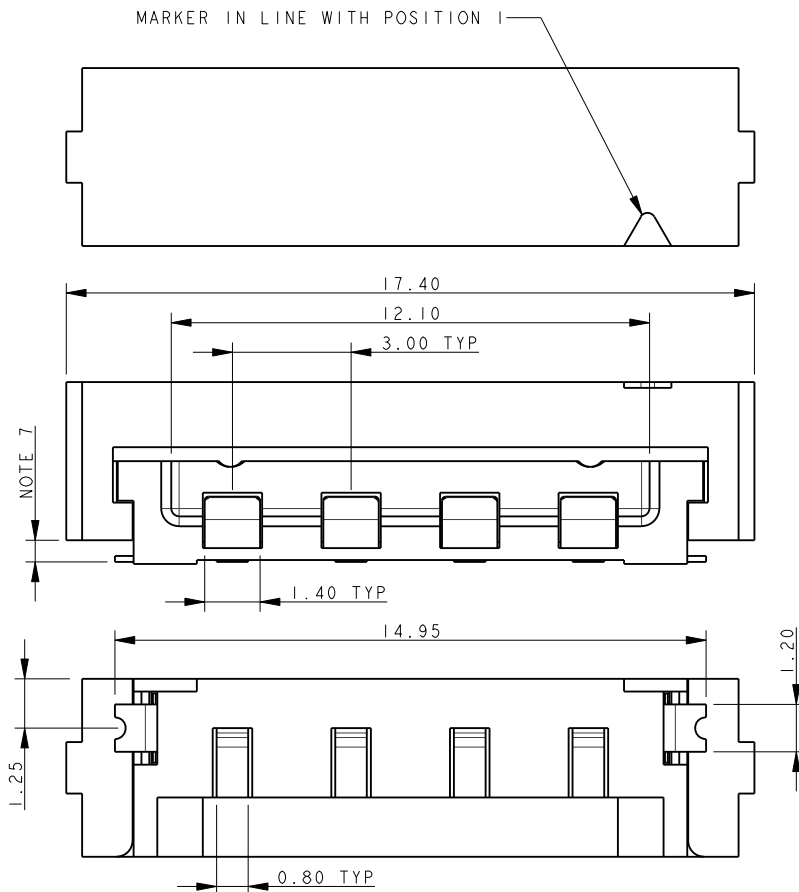

#### NOTES:

1. FOR MORE INFORMATION REFER TO PRODUCT SPEC 201-01-119.
2. DIMENSIONS ARE REFERENCE DIMENSIONS UNLESS TOLERANCES.
3. INSULATOR MATERIAL: NYLON 46. COLOR REFER TO PAGE 44.
4. CONTACT MATERIAL: COPPER ALLOY, GOLD OVER NICKEL.
5. BRACKETS: COPPER ALLOY, TIN PLATED.
6. OUTLINE OF CONNECTOR.
7. RESTRICTED COMPONENT HEIGHT UNDER CATCH, 2.20MM MAXIMUM.
8. RESTRICTED COMPONENT HEIGHT UNDER CATCH, 0.40MM MAXIMUM.
9. PACKING TAPE AND REEL, QUANTITY 1400 PER REEL.

### 4 WAY PCB BOARD LAYOUT

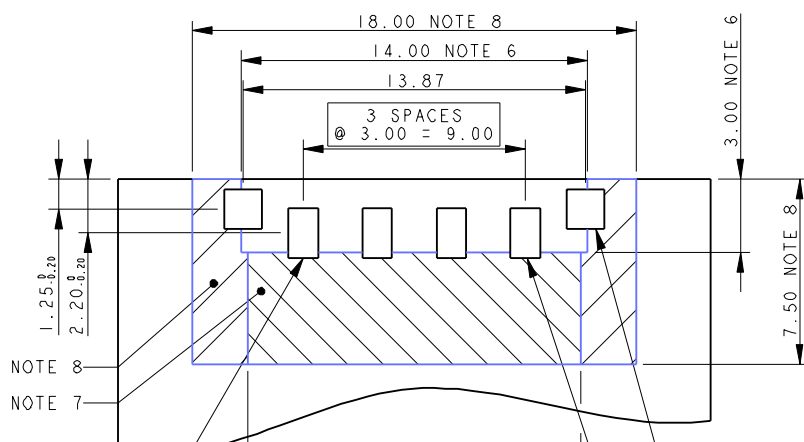

### PACKING DETAILS

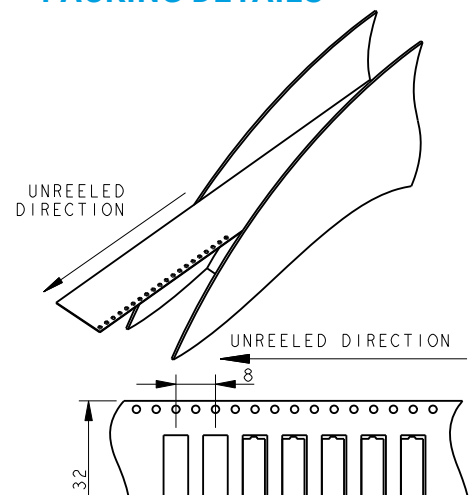

### SOCKET TOP LOADING 5 WAY 2 PART PCB STRIP CONNECTOR

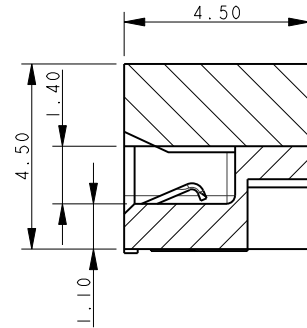
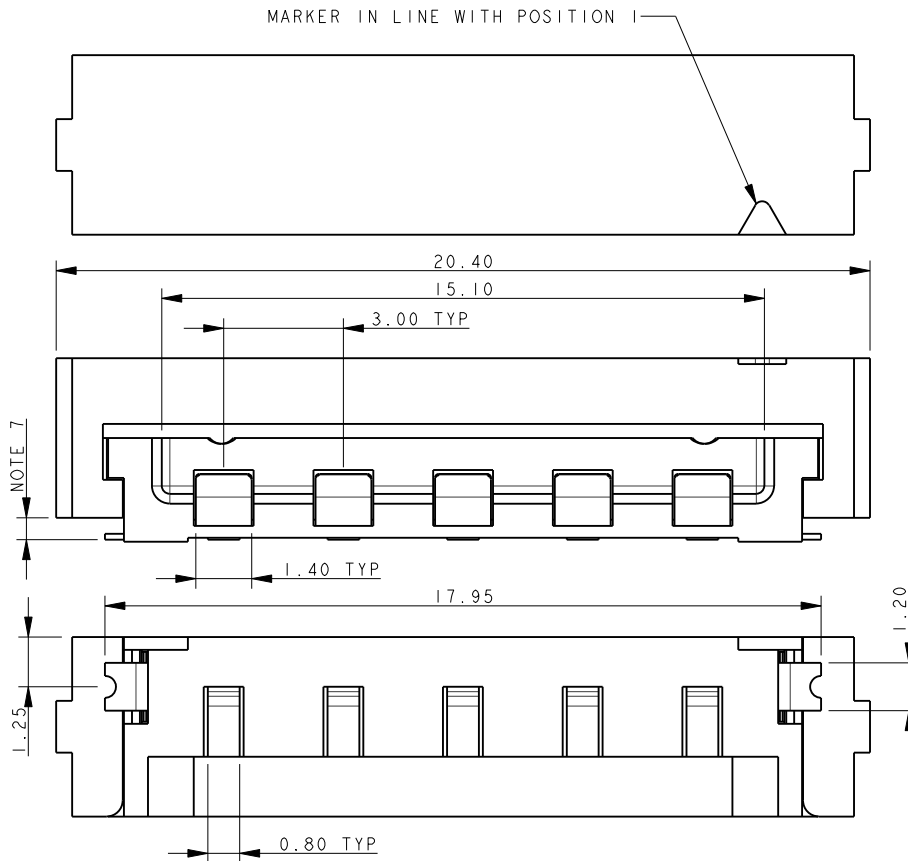

- NOTES:
1. FOR MORE INFORMATION REFER TO PRODUCT SPEC 201-01-119.
  2. DIMENSIONS ARE REFERENCE DIMENSIONS UNLESS TOLERANCES.
  3. INSULATOR MATERIAL: NYLON 46. COLOR REFER TO PAGE 44.
  4. CONTACT MATERIAL: COPPER ALLOY, GOLD OVER NICKEL.
  5. BRACKETS: COPPER ALLOY, TIN PLATED.
  6. OUTLINE OF CONNECTOR.
  7. RESTRICTED COMPONENT HEIGHT UNDER CATCH, 2.20MM MAXIMUM.
  8. RESTRICTED COMPONENT HEIGHT UNDER CATCH, 0.40MM MAXIMUM.
  9. PACKING TAPE AND REEL, QUANTITY 1400 PER REEL

### 5 WAY PCB BOARD LAYOUT

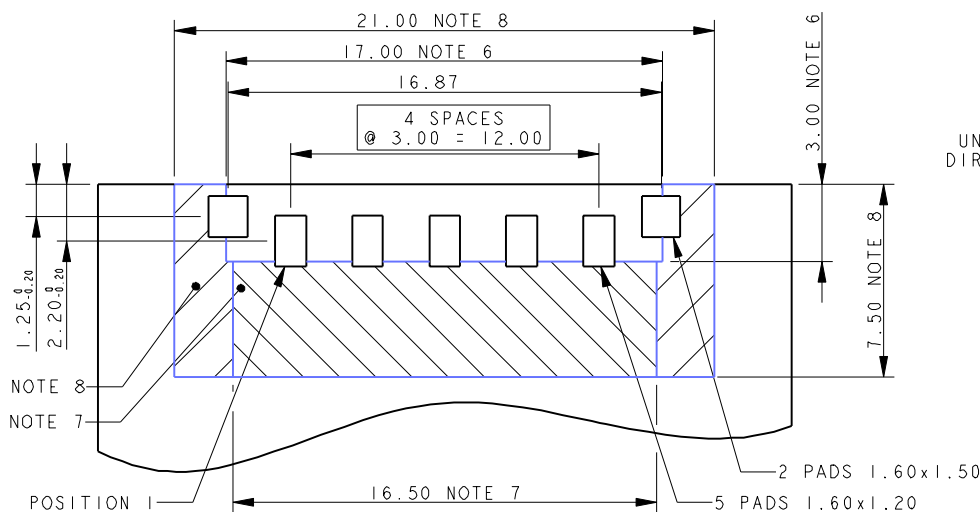

### PACKING DETAILS

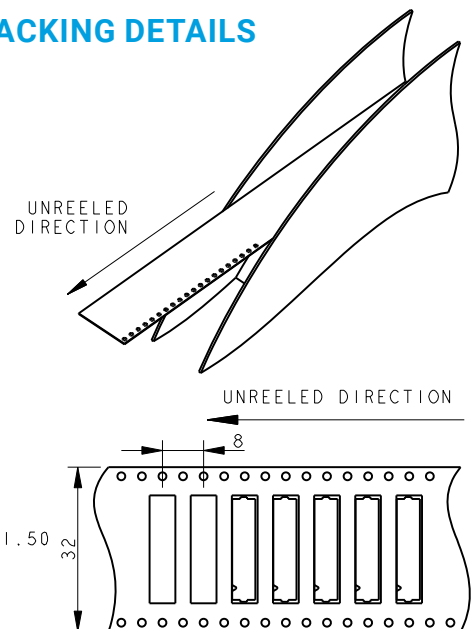

# Top Load Socket: 22-9159-100

## 6 Position



### SOCKET TOP LOADING 6 WAY 2 PART PCB STRIP CONNECTOR

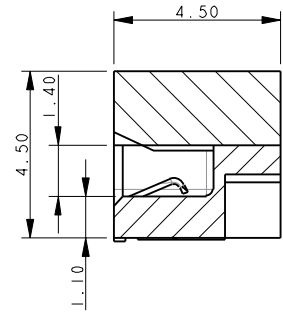
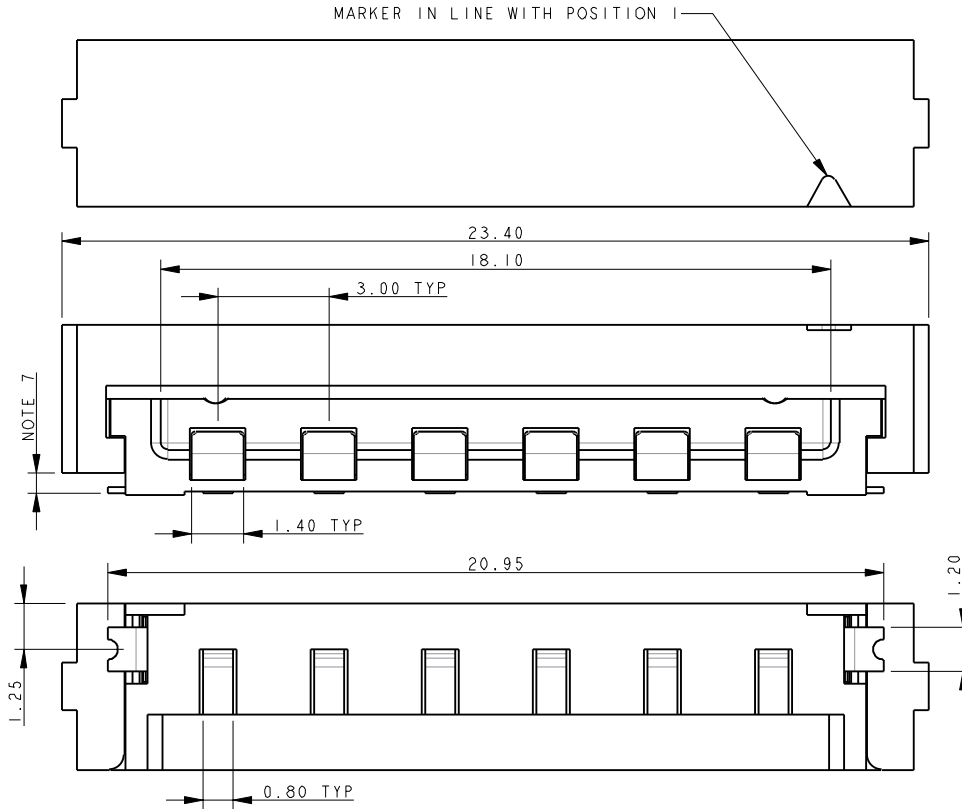

#### NOTES:

1. FOR MORE INFORMATION REFER TO PRODUCT SPEC 201-01-119.
2. DIMENSIONS ARE REFERENCE DIMENSIONS UNLESS TOLERANCES.
3. INSULATOR MATERIAL: NYLON 46. COLOR REFER TO PAGE 44.
4. CONTACT MATERIAL: COPPER ALLOY, GOLD OVER NICKEL.
5. BRACKETS: COPPER ALLOY, TIN PLATED.
6. OUTLINE OF CONNECTOR.
7. RESTRICTED COMPONENT HEIGHT UNDER CATCH, 2.20MM MAXIMUM.
8. RESTRICTED COMPONENT HEIGHT UNDER CATCH, 0.40MM MAXIMUM.
9. PACKING TAPE AND REEL, QUANTITY 1400 PER REEL.

### 6 WAY PCB BOARD LAYOUT

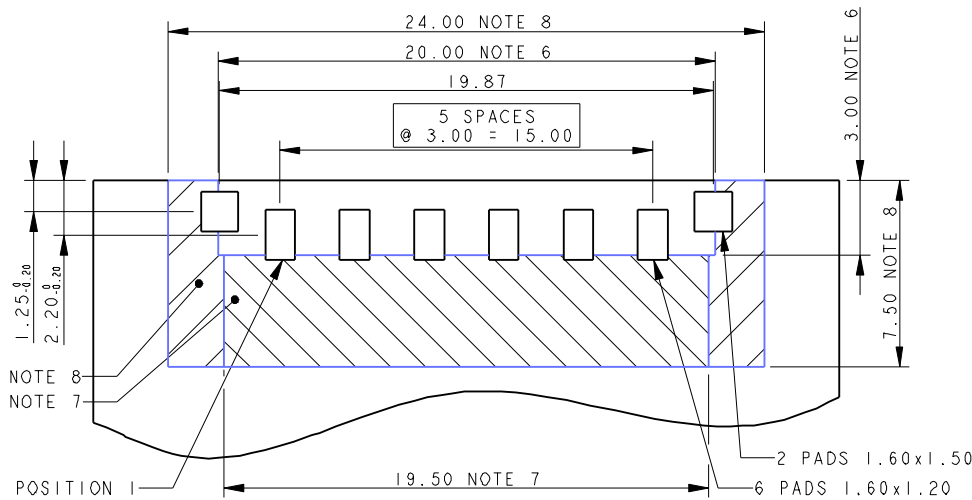

### PACKING DETAILS

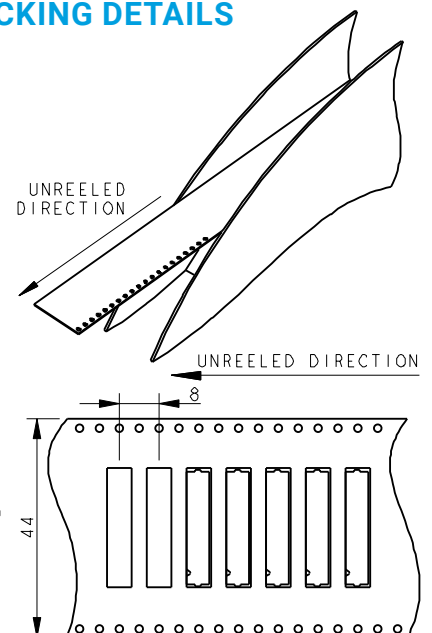

CONNECTOR ASSEMBLY



COVER FORWARD (LOCKED)



COVER SLID BACK



DROP PCB ASSEMBLY ONTO MATING CONNECTORS

