

DC Brushless Fan Motor Drivers

Multifunction Single-phase Full-wave Fan Motor Driver

BD6994FV
General Description

BD6994FV is a 1chip driver for 12V single-phase full-wave fan motor. This IC employs the Bi-CMOS process and incorporates various functions such as low ON resistance, low power consumption and quiet drive.

Key Specifications

- Operating Voltage Range: 4.5V to 17V
- Operating Temperature Range: -40°C to +105°C
- Output Voltage (Total): 0.6V(Typ) at 0.4A

Features

- SSOP Small Package
- BTL Soft Switching Drive
- Stand-by Function
- Speed Controllable by DC / Pulse Input
- Quick Start
- Duty Control Start-up Function
- Lock Protection and Automatic Restart (without External Capacitor)
- Rotation Speed Pulse Signal (FG) Output
- Lock Alarm Signal(AL) Output

Package

SSOP-B16

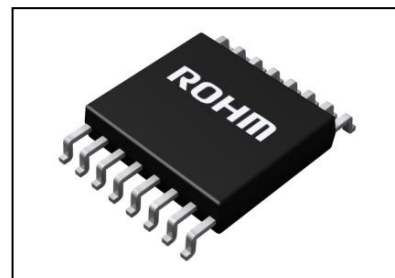
 W (Typ) x D (Typ) x H (Max)
 5.00mm x 6.40mm x 1.35mm

SSOP-B16
Application

- Fan motors for general consumer equipment of desktop PC, Projector, etc.

Absolute Maximum Ratings

Parameter	Symbol	Limit	Unit
Supply Voltage	V_{CC}	20	V
Power Dissipation	P_d	0.87 (Note 1)	W
Operating Temperature Range	T_{opr}	-40 to +105	°C
Storage Temperature Range	T_{stg}	-55 to +150	°C
Output Voltage	V_o	20	V
Output Current	I_o	1.2 (Note 2)	A
Signal(FG/AL) Output Voltage	V_{FG}/V_{AL}	20	V
Signal(FG/AL) Output Current	I_{FG}/I_{AL}	10	mA
Reference Voltage(REF) Output Current	I_{REF}	5	mA
Hall Bias(HB) Output Current 1	I_{HB1}	12 (Note 3)	mA
Hall Bias(HB) Output Current 2	I_{HB2}	5 (Note 4)	mA
Input Voltage(H+, H-, TH, MIN, SEL, PS)	V_{IN}	7	V
Junction Temperature	T_{jmax}	150	°C

(Note 1) Derate by 7.0mW/°C if operating over $T_a=25^\circ\text{C}$. (On 70.0mm×70.0mm×1.6mm glass epoxy board)

(Note 2) Do not exceed P_d and T_{jmax} .

(Note 3) $T_a=0^\circ\text{C}$ or Higher.

(Note 4) Less than $T_a=0^\circ\text{C}$.

Caution: Operating the IC over the absolute maximum ratings may damage the IC. The damage can either be a short circuit between pins or an open circuit between pins and the internal circuitry. Therefore, it is important to consider circuit protection measures, such as adding a fuse, in case the IC is operated over the absolute maximum ratings.

Recommended Operating Conditions

Parameter	Symbol	Limit	Unit
Operating Supply Voltage Range	V_{CC}	4.5 to 17.0	V
Operating Input Voltage Range 1(H+, H-) ($V_{CC}\geq 9V$)	V_{IN1}	0.4 to 3	V
Operating Input Voltage Range 1(H+, H-) ($V_{CC}< 9V$)		0.4 to $V_{CC}/3$	V
Operating Input Voltage Range 2(TH, MIN)	V_{IN2}	0.4 to V_{REF}	V

○Product structure : Silicon monolithic integrated circuit ○This product has no designed protection against radioactive rays

Pin Configuration

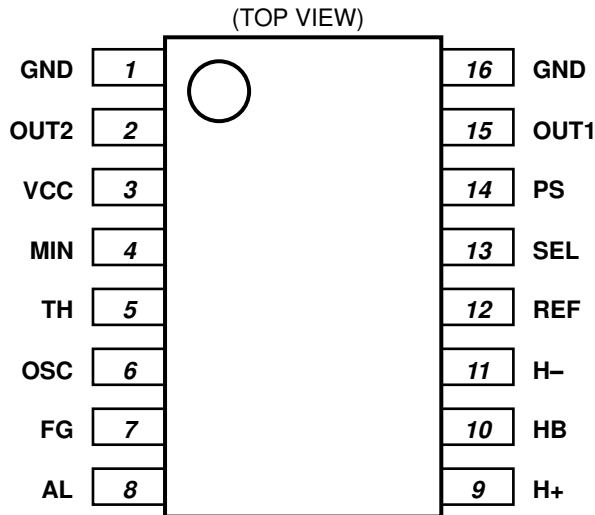

Figure 1. Pin Configuration

Pin Description

P/No.	P/Name	Function
1	GND	Ground pin
2	OUT2	Motor output 2 pin
3	VCC	Power supply pin
4	MIN	Minimum output duty setting pin
5	TH	Output duty controllable input pin
6	OSC	Oscillating capacitor connecting pin
7	FG	Speed pulse signal output pin
8	AL	Lock alarm signal output pin
9	H+	Hall + input pin
10	HB	Hall bias pin
11	H-	Hall - input pin
12	REF	Reference voltage output pin
13	SEL	Duty control start up function selecting pin
14	PS	Power save pin
15	OUT1	Motor output 1 pin
16	GND	Ground pin

Block Diagram

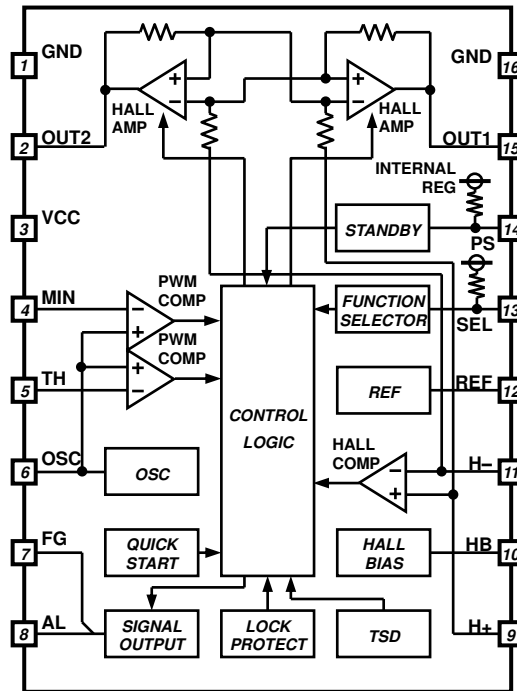

Figure 2. Block Diagram

I/O Truth Table

Hall Input		Driver Output		
H+	H-	OUT1	OUT2	FG
H	L	L	H	Hi-Z
L	H	H	L	L

H; High, L; Low, Hi-Z; High impedance
FG output is open-drain type.

Motor State	FG Output	AL Output
Rotating	-	L
Locking	-	Hi-Z
Stand-by	Hi-Z	L

L; Low, Hi-Z; High impedance
AL output is open-drain type.

Electrical Characteristics (Unless otherwise specified, Ta=25°C, Vcc=12V)

Parameter	Symbol	Limit			Unit	Conditions
		Min	Typ	Max		
Circuit Current	I _{CC}	-	6.5	9.5	mA	
Circuit Current(Stand-by)	I _{STBY}	70	160	250	μA	PS=0V
Hall Bias Voltage	V _{HB}	1.05	1.25	1.45	V	I _{HB} =-2mA
Hall Input Offset Voltage	V _{OFS}	-	-	±8	mV	
Input-Output Gain	G _{IO}	46.0	48.5	51.0	dB	
Output Voltage	V _O	-	0.6	0.9	V	I _O =±400mA High and low side total
Lock Detection ON Time	t _{ON}	0.3	0.5	0.7	s	
Lock Detection OFF Time	t _{OFF}	3.0	5.0	7.0	s	
Lock Detection OFF/ON Ratio	R _{LCK}	8.5	10	11.5	-	R _{LCK} =T _{OFF} / T _{ON}
FG Hysteresis Voltage	V _{HYS}	±7	±12	±17	mV	
FG Output Low Voltage	V _{FGL}	-	0.2	0.3	V	I _{FG} =5mA
FG Output Leak Current	I _{FGL}	-	-	10	μA	V _{FG} =17V
AL Output Low Voltage	V _{ALL}	-	0.2	0.3	V	I _{AL} =5mA
AL Output Leak Current	I _{ALL}	-	-	10	μA	V _{AL} =17V
OSC Frequency(Reference Data)	F _{OSC}	-	26	-	kHz	C _{OSC} =100pF
OSC Charge Current	I _{COSC}	-16	-11	-6	μA	
OSC Discharge Current	I _{DOSC}	6	11	16	μA	
OSC High Voltage	V _{OSCH}	3.4	3.6	3.8	V	
OSC Low Voltage	V _{OSCL}	1.3	1.5	1.7	V	
Output ON Duty 1	D _{OH1}	70	80	90	%	V _{TH} =1.8V Output 1kΩ load
Output ON Duty 2	D _{OH2}	40	50	60	%	V _{TH} =2.4V Output 1kΩ load
Output ON Duty 3	D _{OH3}	10	20	30	%	V _{TH} =3.1V Output 1kΩ load
Re-Circulate Ratio(Reference Data)	R _{RC}	-	50	-	%	V _{TH} =1.65V
Reference Voltage	V _{REF}	4.8	5.1	5.4	V	I _{REF} =-2mA
TH Input Bias Current	I _{TH}	-0.6	-	-	μA	V _{TH} =0.2V
MIN Input Bias Current	I _{MIN}	-0.6	-	-	μA	V _{MIN} =0.2V
SEL Input Open Voltage	V _{SEL}	2.9	3.2	3.5	V	
SEL Input Low Level	V _{SELL}	-0.3	-	0.8	V	
SEL Input Bias Current	I _{SEL}	-35	-25	-15	μA	V _{SEL} =0V
PS Input Open Voltage	V _{PS}	4.2	4.7	5.2	V	
PS Input Low Level	V _{PSL}	-0.3	-	0.8	V	
PS Input High Level	V _{PSH}	2.5	-	5.5	V	
PS Input Bias Current	I _{PS}	-35	-25	-15	μA	V _{PS} =0V
Limit ON Duty at Start-up	D _{OHL}	43	53	63	%	V _{SEL} =0V, V _{TH} <V _{REF} -0.5V
Limit ON Duty Time at Start-up	t _{OHL}	0.3	0.5	0.7	s	V _{SEL} =0V, V _{TH} <V _{REF} -0.5V
Start Assist Duty 1	D _{OHS1}	23	33	43	%	V _{SEL} =0V, V _{TH} >V _{REF} -0.1V
Start Assist Duty 2	D _{OHS2}	43	53	53	%	SEL=OPEN, V _{TH} >V _{REF} -0.1V

For parameters involving current, positive nations means inflow of current to IC while negative nation means outflow of current from IC.
The reference data is a design guaranteed value and the numerical all shipment inspection off the subject item.

Typical Performance Curves (Reference Data)

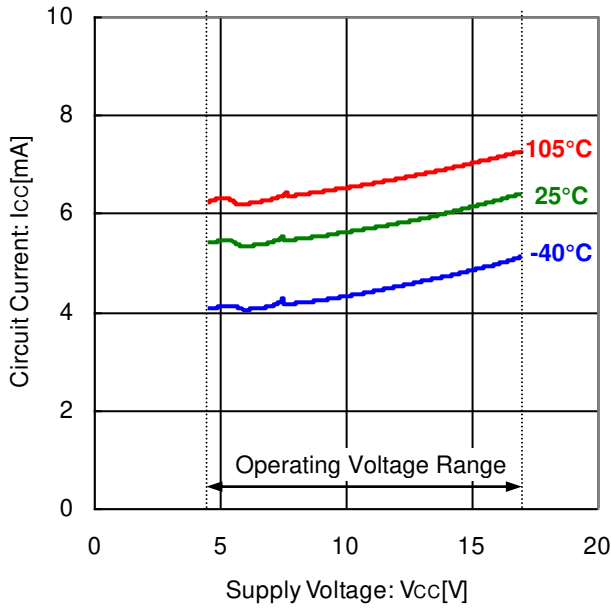

Figure 3. Circuit Current vs Supply Voltage (In Operation)

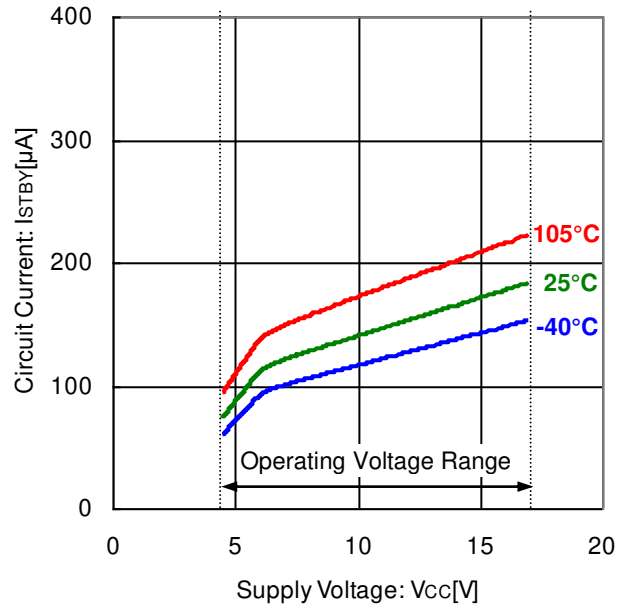

Figure 4. Circuit Current vs Supply Voltage (In Standby)

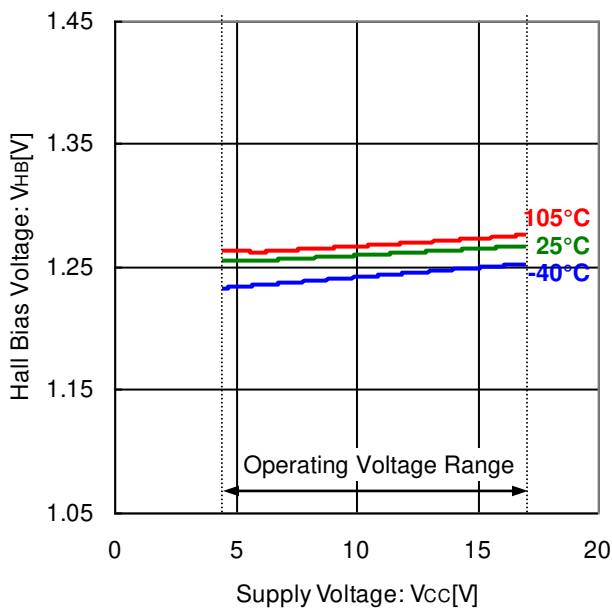

Figure 5. Hall Bias Voltage vs Supply Voltage (IHB=2mA)

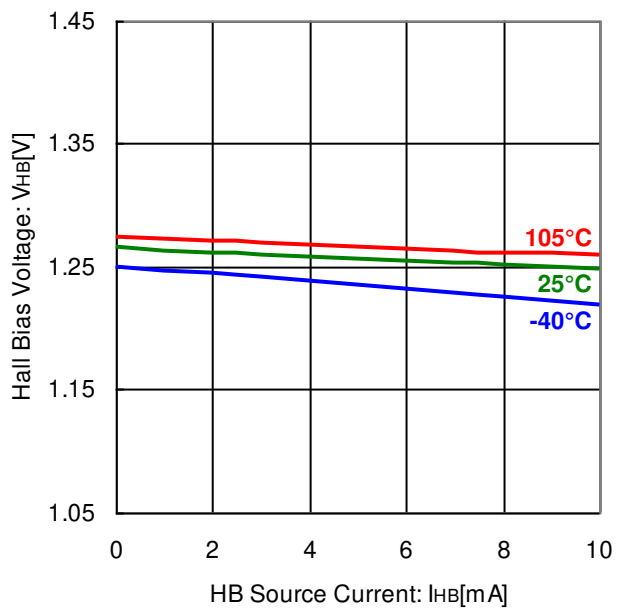

Figure 6. Hall Bias Voltage vs HB Source Current (Vcc=12V)

Typical Performance Curves (Reference Data) - Continued

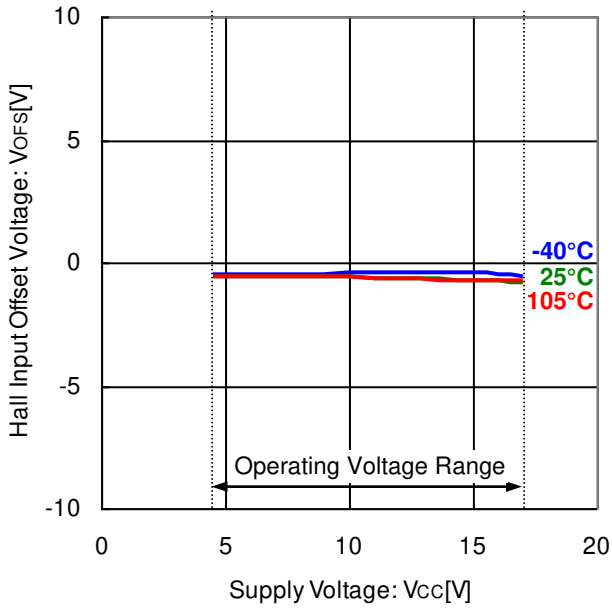

Figure 7. Hall Input Offset Voltage vs Supply Voltage

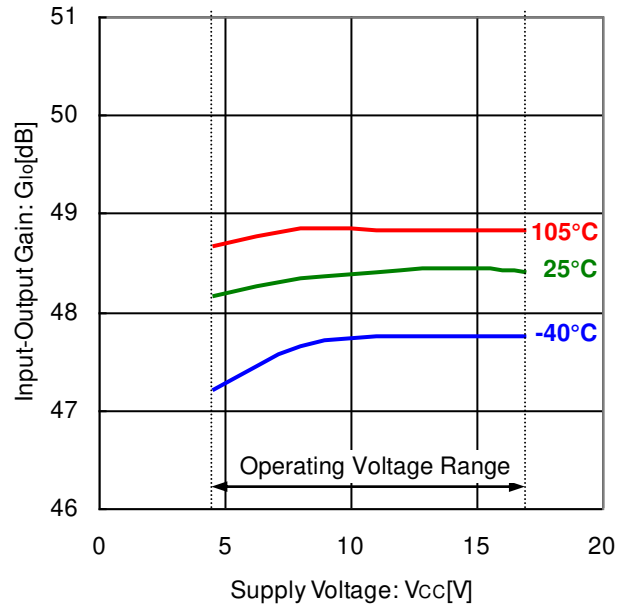

Figure 8. Input-Output Gain vs Supply Voltage

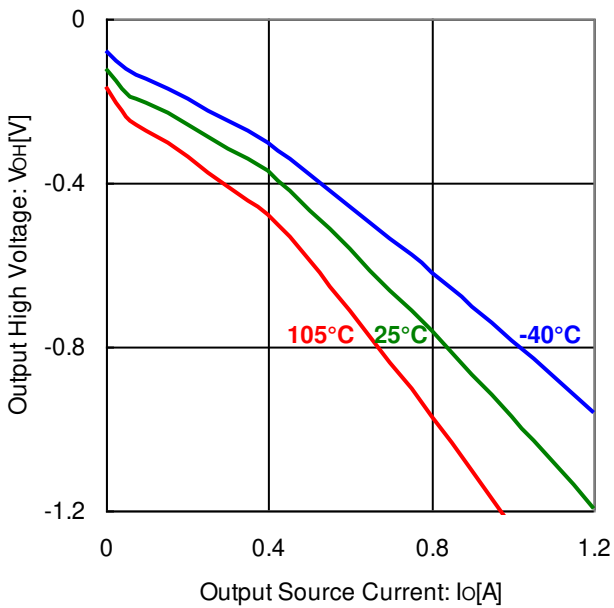

Figure 9. Output High Voltage vs Output Source Current (V_{CC}=12V)

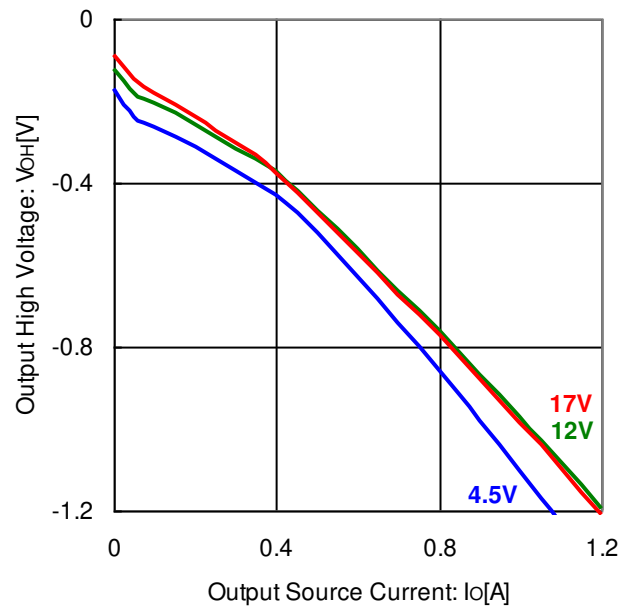

Figure 10. Output High Voltage vs Output Source Current (T_a=25°C)

Typical Performance Curves (Reference Data) - Continued

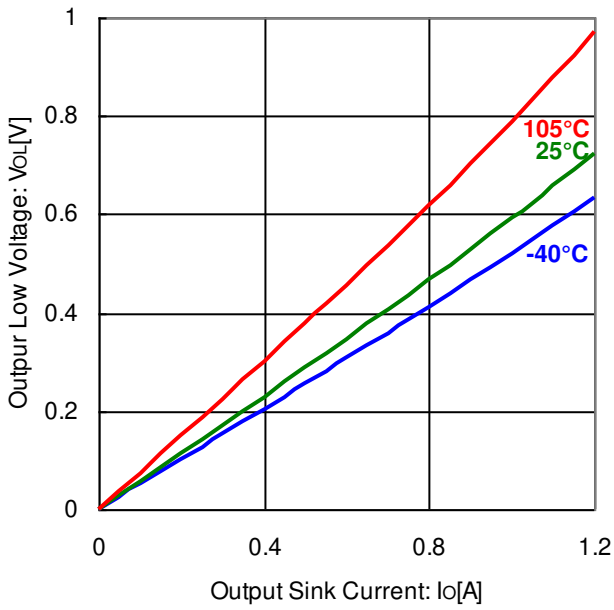

Figure 11. Output Low Voltage vs Output Sink Current (V_{CC}=12V)

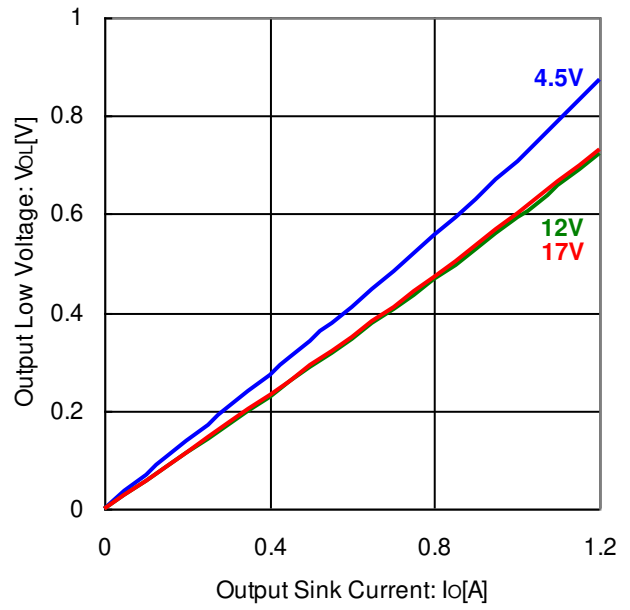

Figure 12. Output Low Voltage vs Output Sink Current (T_a=25°C)

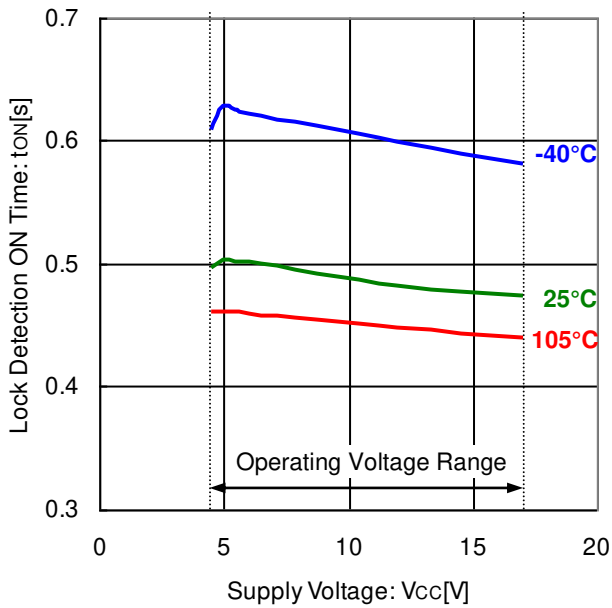

Figure 13. Lock Detection ON Time vs Supply Voltage

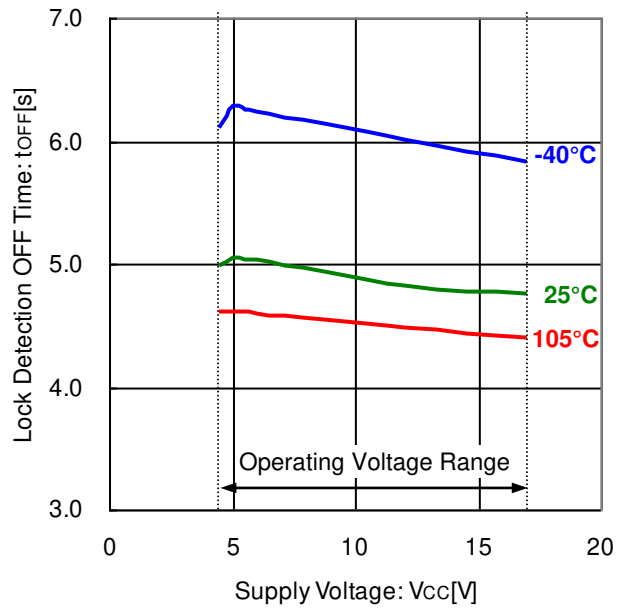

Figure 14. Lock Detection OFF Time vs Supply Voltage

Typical Performance Curves (Reference Data) - Continued

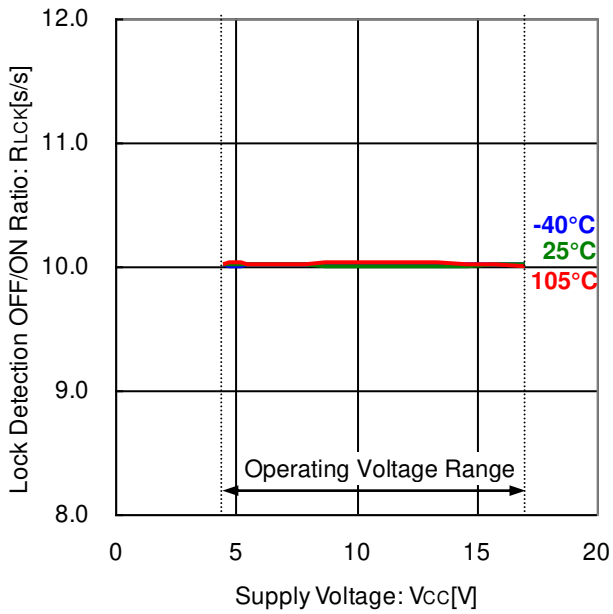

Figure 15. Lock Detection OFF/ON Ratio vs Supply Voltage

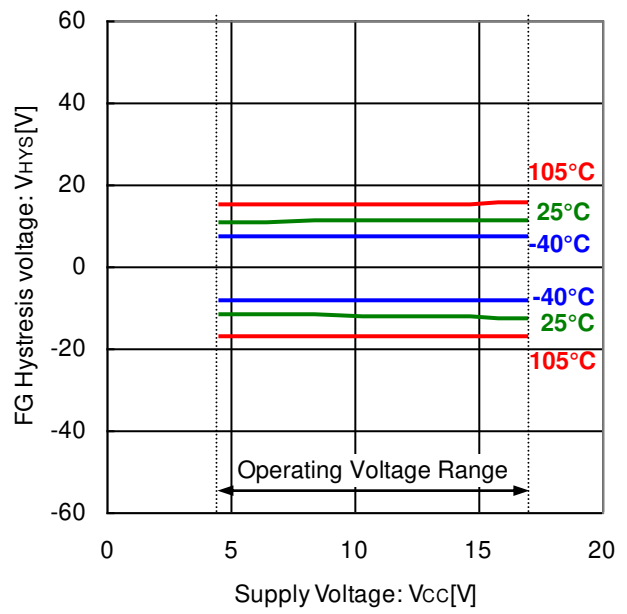

Figure 16. FG Hysteresis Voltage vs Supply Voltage

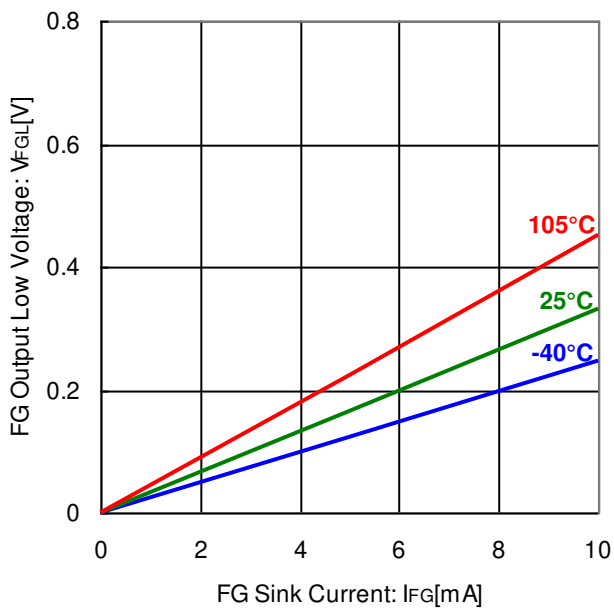

Figure 17. FG Output Low Voltage vs FG Sink Current (V_{CC}=12V)

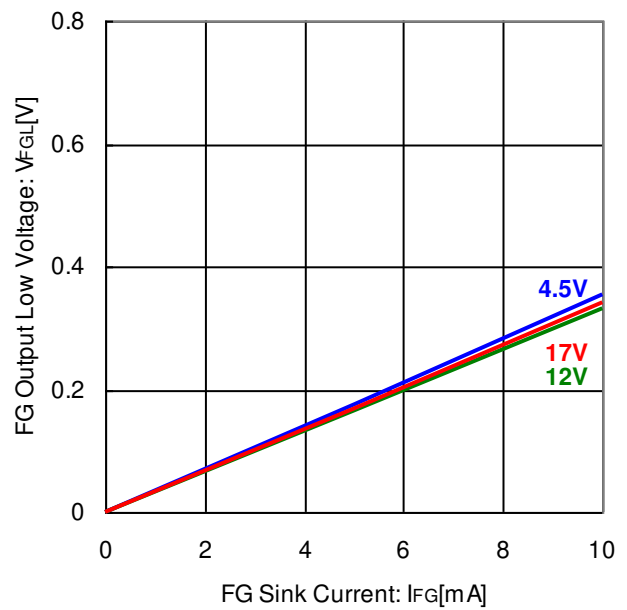

Figure 18. FG Output Voltage vs FG Sink Current (T_a=25°C)

Typical Performance Curves (Reference Data) - Continued

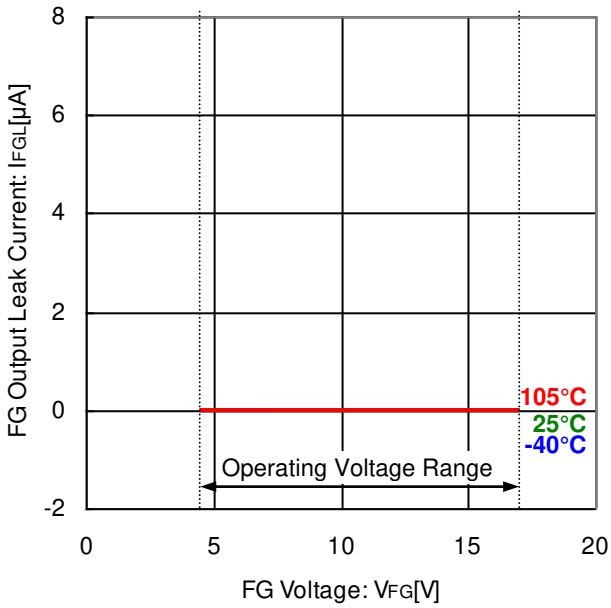

Figure 19. FG Output Leak Current vs FG Voltage

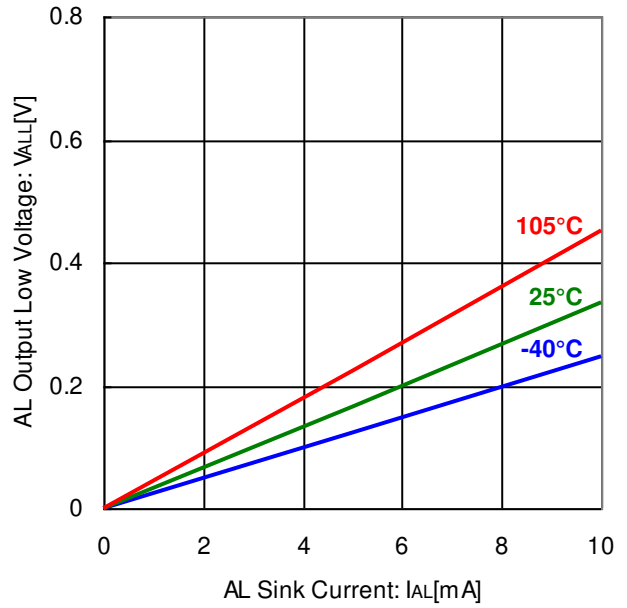

Figure 20. AL Output Low Voltage vs AL Sink Current (V_{CC}=12V)

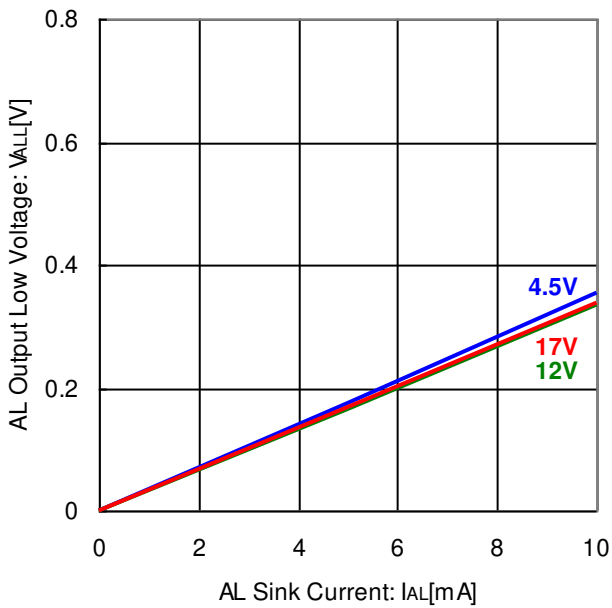

Figure 21. AL Output Low Voltage vs AL Sink Current (Ta=25°C)

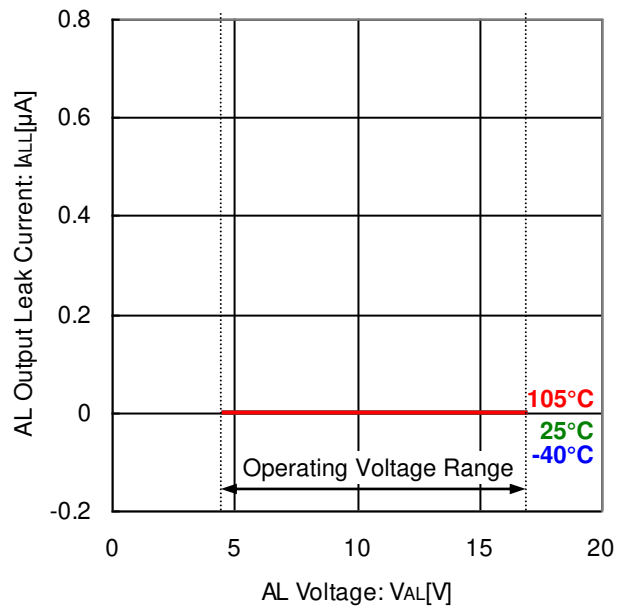

Figure 22. AL Output Leak Current vs AL Voltage

Typical Performance Curves (Reference Data) – Continued

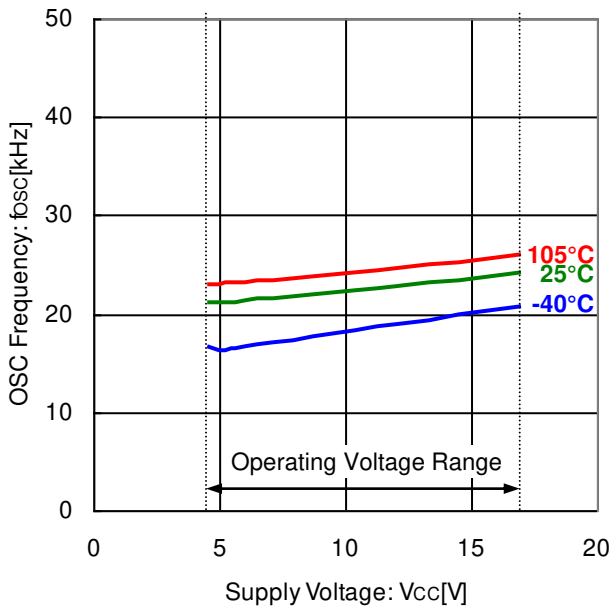

Figure 23. OSC Frequency vs Supply Voltage (Reference Data; $C_{OSC}=100pF$)

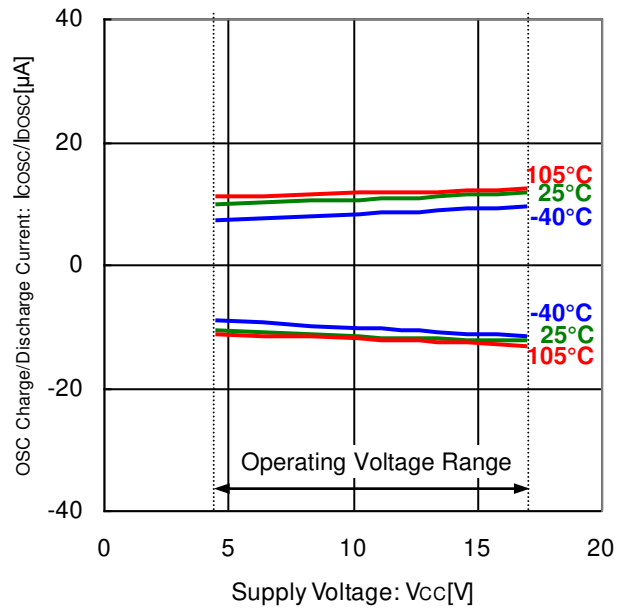

Figure 24. OSC Charge/Discharge Current vs Supply Voltage

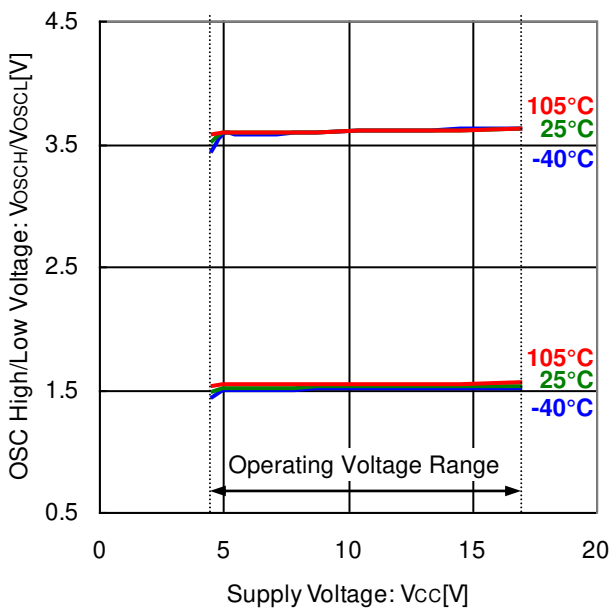

Figure 25. OSC High/Low Voltage vs Supply Voltage

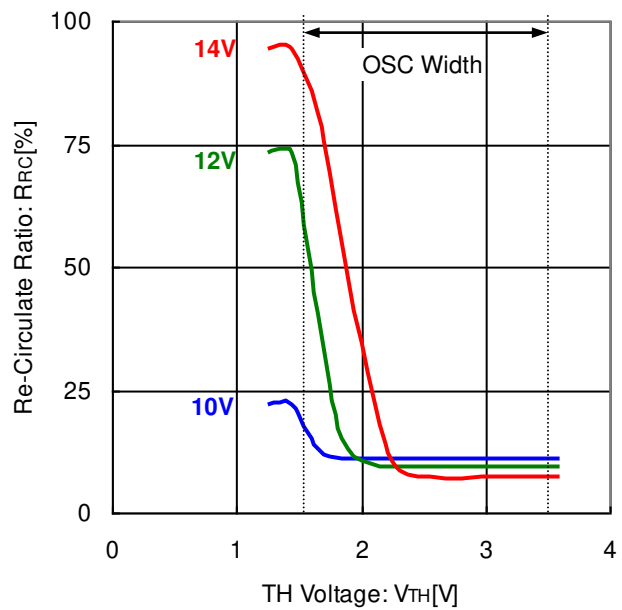

Figure 26. Re-Circulate Ratio vs TH Voltage (Reference Data; $T_a=25^{\circ}C$)

Typical Performance Curves (Reference Data) – Continued

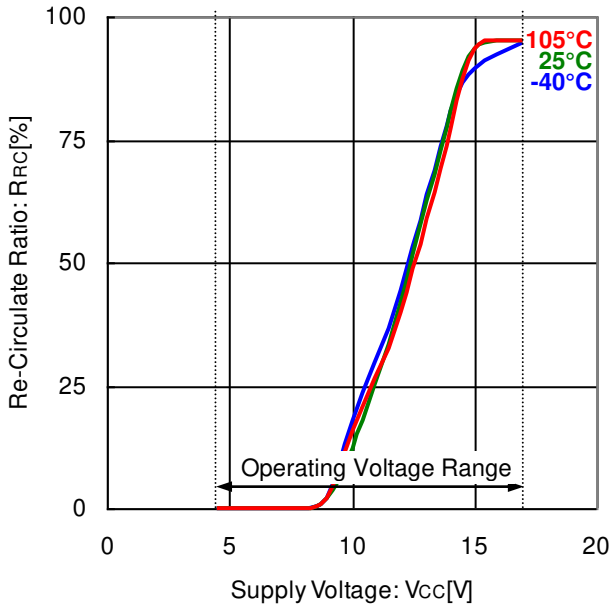

Figure 27. Re-Circulate Ratio vs Supply Voltage (Reference Data; $V_{TH}=1.65V$)

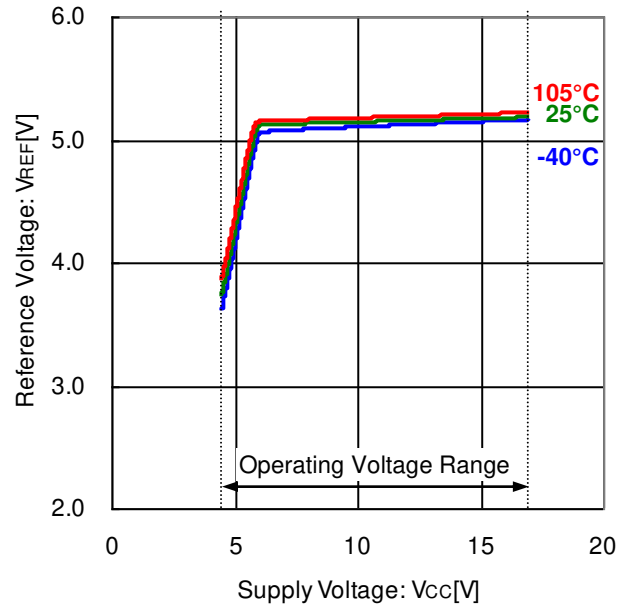

Figure 28. Reference Voltage vs Supply Voltage ($I_{REF}=-2mA$)

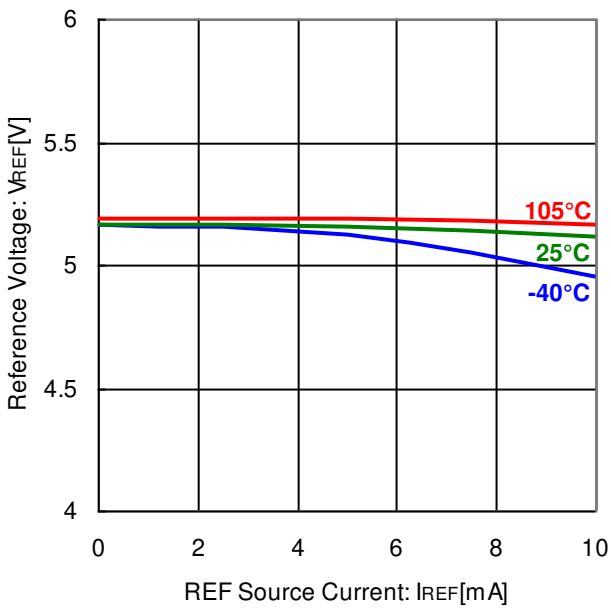

Figure 29. Reference Voltage vs REF Source Current ($V_{CC}=12V$)

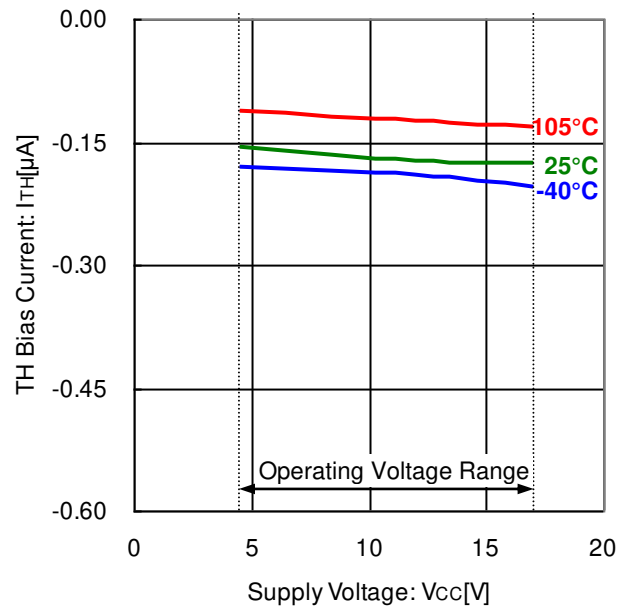

Figure 30. TH Bias Current vs Supply Voltage

Typical Performance Curves (Reference Data) – Continued

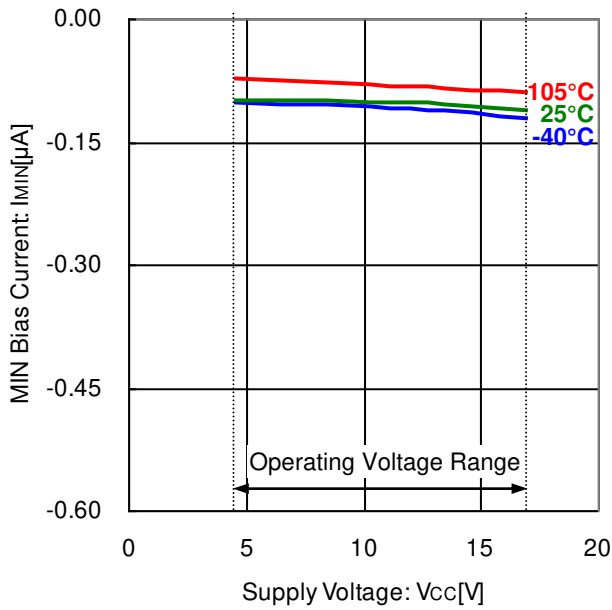

Figure 31. MIN Bias Current vs Supply Voltage

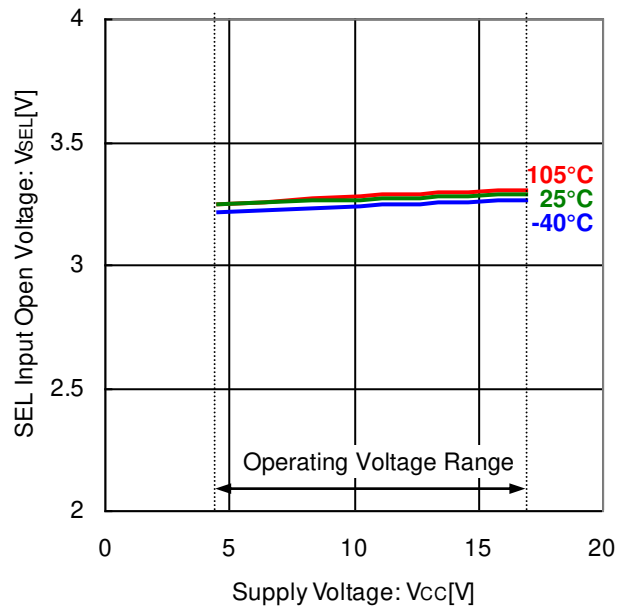

Figure 32. SEL Input Open Voltage vs Supply Voltage

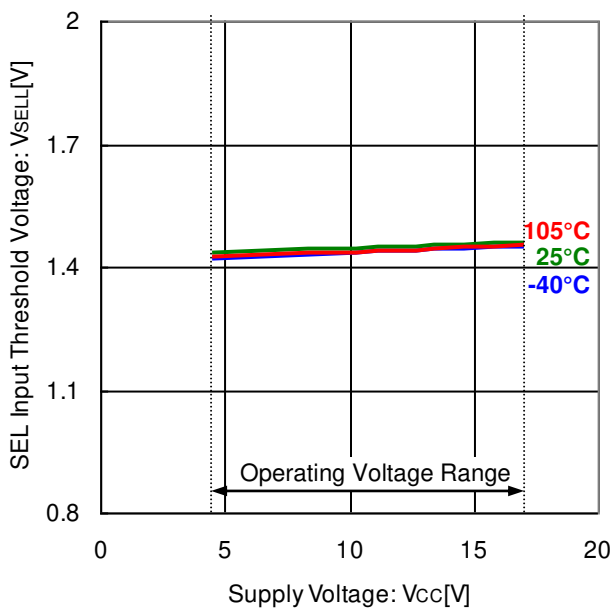

Figure 33. SEL Input Threshold Voltage vs Supply Voltage

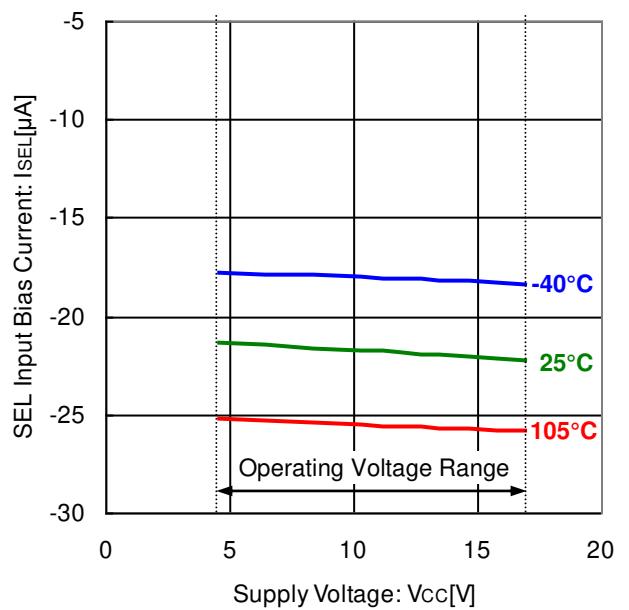

Figure 34. SEL Input Bias Current vs Supply Voltage

Typical Performance Curves (Reference Data) – Continued

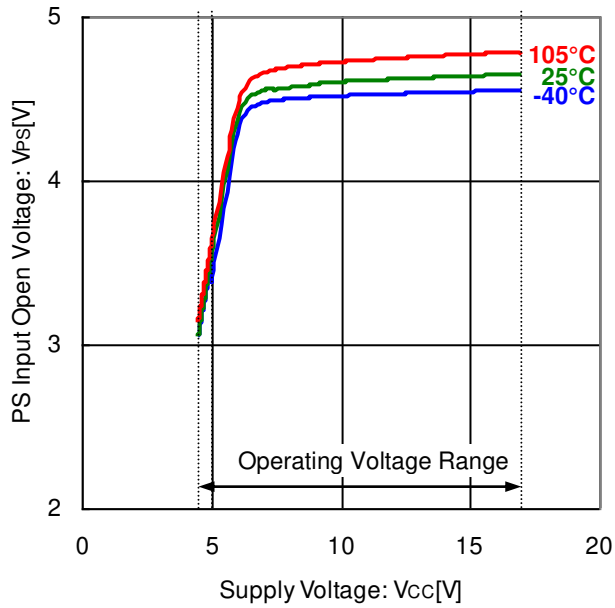

Figure 35. PS Input Open Voltage vs Supply Voltage

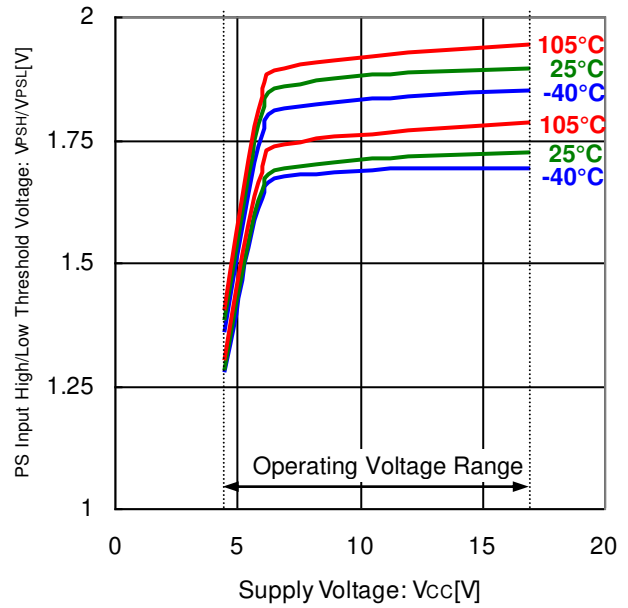

Figure 36. PS Input High/Low Threshold Voltage vs Supply Voltage

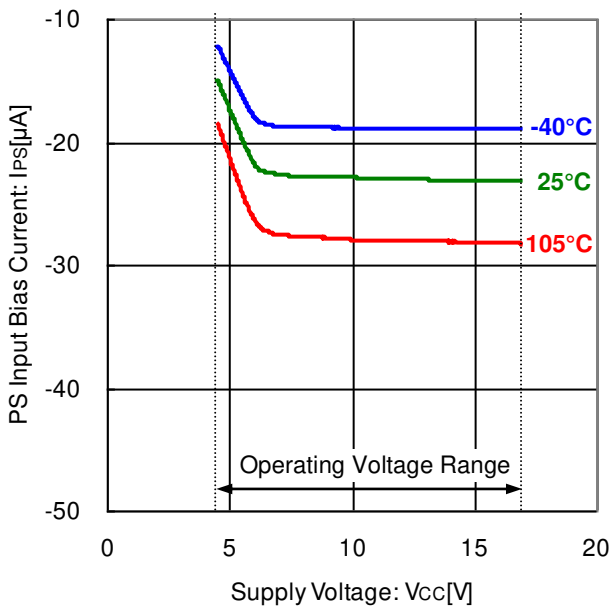

Figure 37. PS Input Bias Current vs Supply Voltage

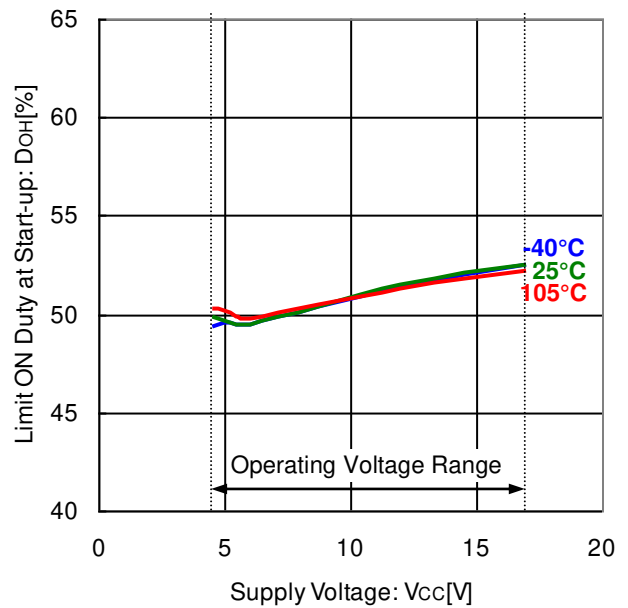

Figure 38. Limit ON Duty Time at Start-up vs Supply Voltage

Typical Performance Curves (Reference Data) – Continued

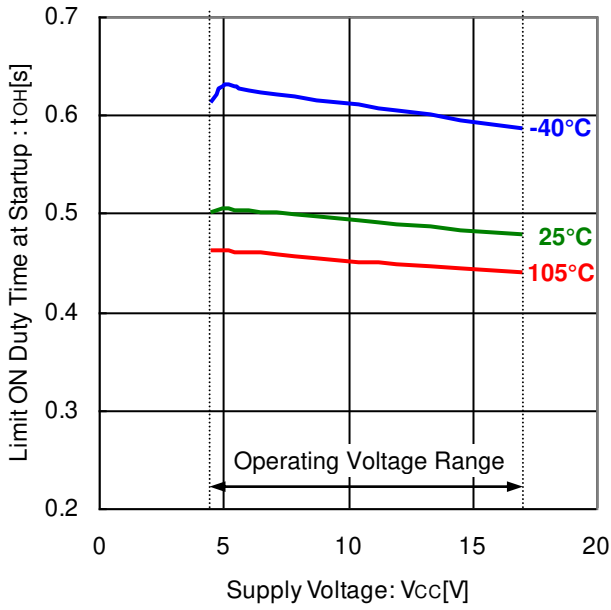

Figure 39. Limit ON Duty Time at Start-up vs Supply Voltage

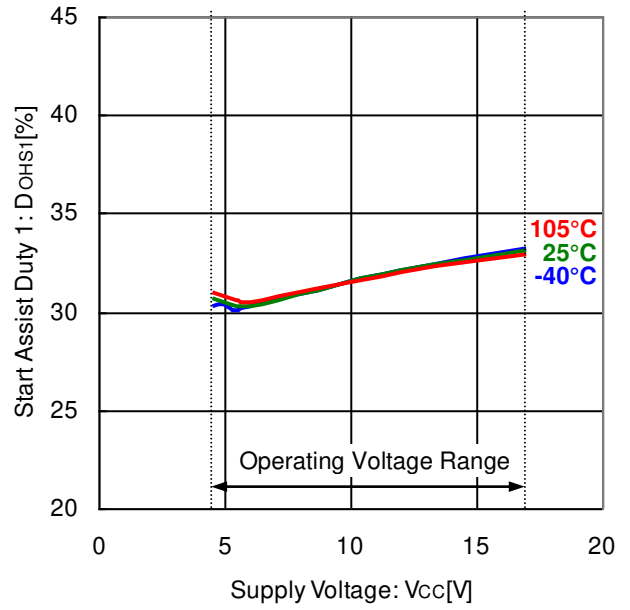

Figure 40. Start Assist Duty 1 vs Supply Voltage

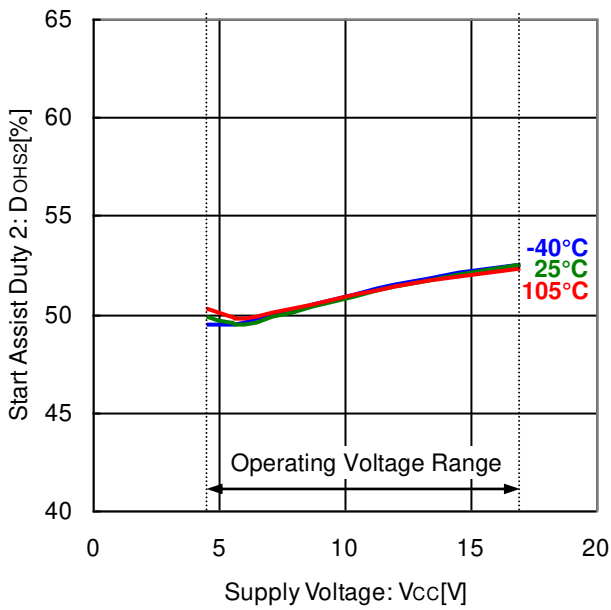

Figure 41. Start Assist Duty 2 vs Supply Voltage

Application Circuit Example (Constant Values are for Reference)

1. PWM Input Application 1 (Use of stand-by function)

This is an example application circuit for converting the external PWM duty into DC voltage, and controlling the rotational speed.

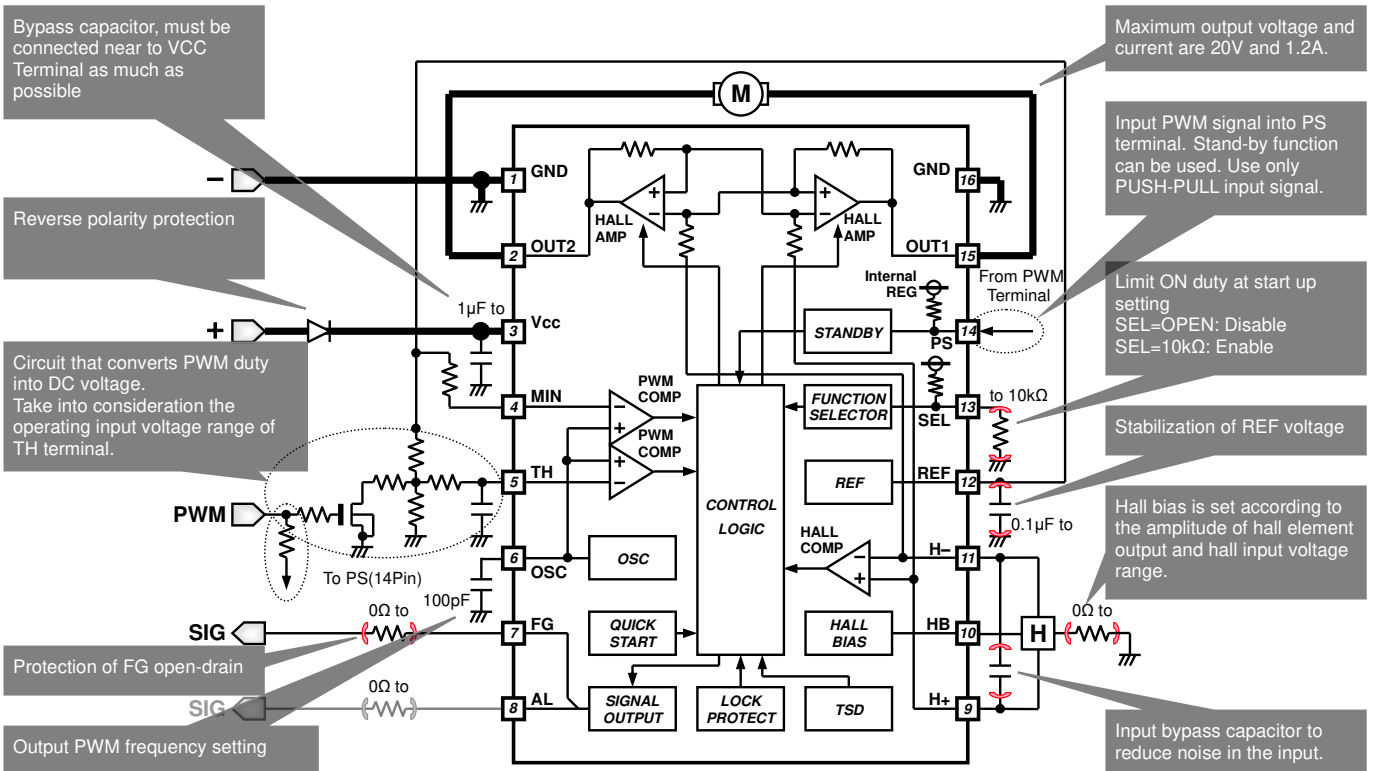

Figure 42. Application of Converting PWM Duty to DC Voltage

Substrate Design Note

- a) IC power, motor outputs, and motor ground lines are made as wide as possible.
- b) The bypass capacitor and/or Zener diode are connected near to VCC terminal.
- c) H+ and H- lines are arranged side by side and connected from the hall element to the IC as short as possible, because it is easy for the noise to influence the hall lines.

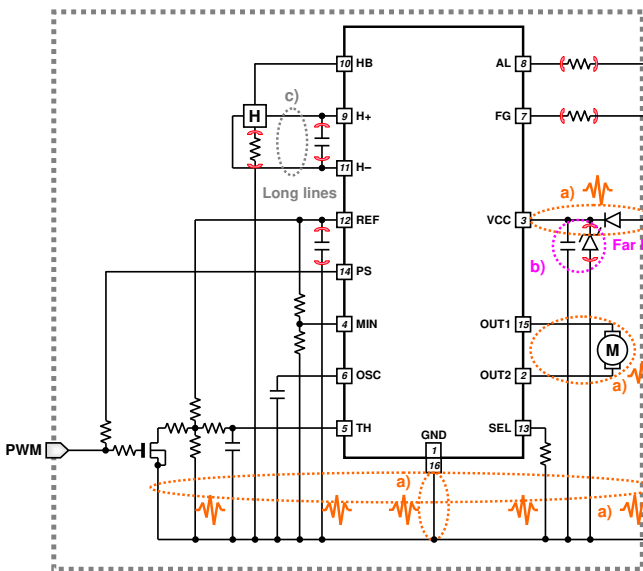

Figure 43. Bad Layout Image of the Substrate

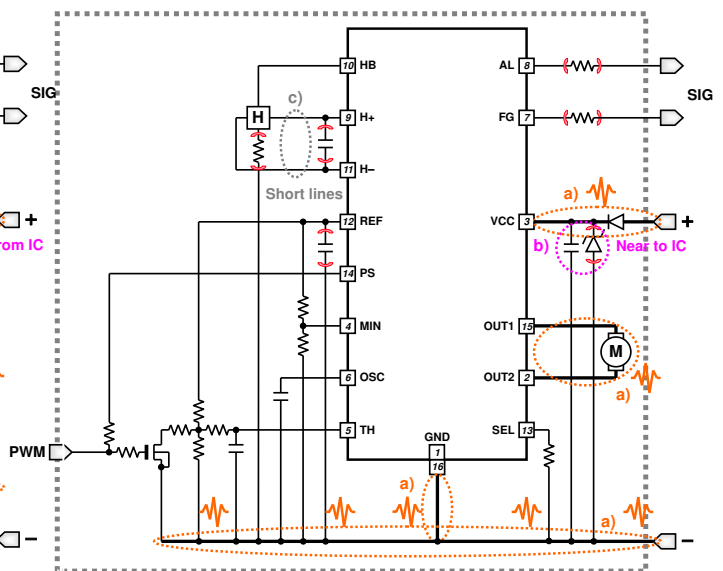

Figure 44. Good Layout Image of the Substrate

Application Circuit Example (Constant Values are for Reference)

2. DC Voltage Input Application 1

This is an example application circuit for fixed rotation speed control by DC voltage. In this application, minimum rotational speed cannot be set. Moreover, output duty changes depending on the TH voltage. Function of limit ON duty at start up can be set using the SEL terminal.

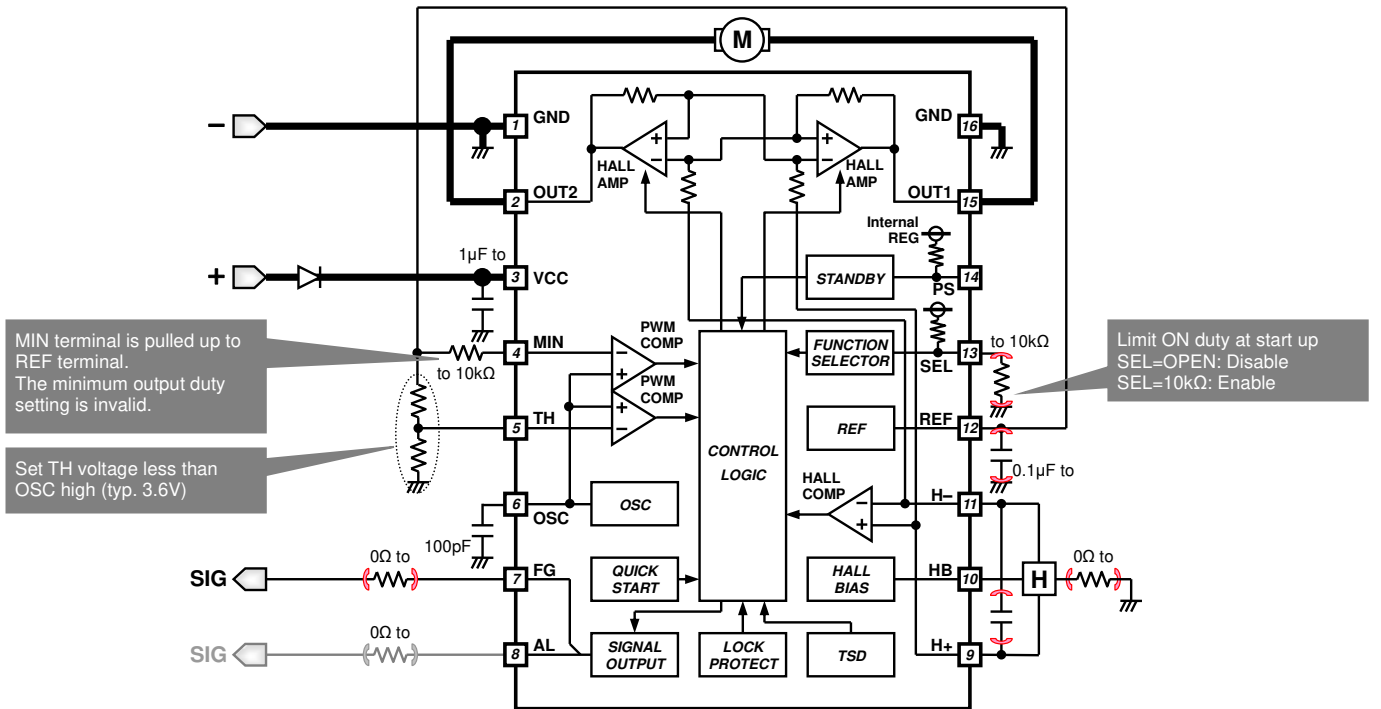

Figure 45. Application of DC Voltage Input 1

3. DC Voltage Input Application 2

This is an example application circuit for fixed rotation speed control by DC voltage. In this application, output duty changes depending on the MIN voltage. Function of Start Duty Assist can be set using the SEL terminal.

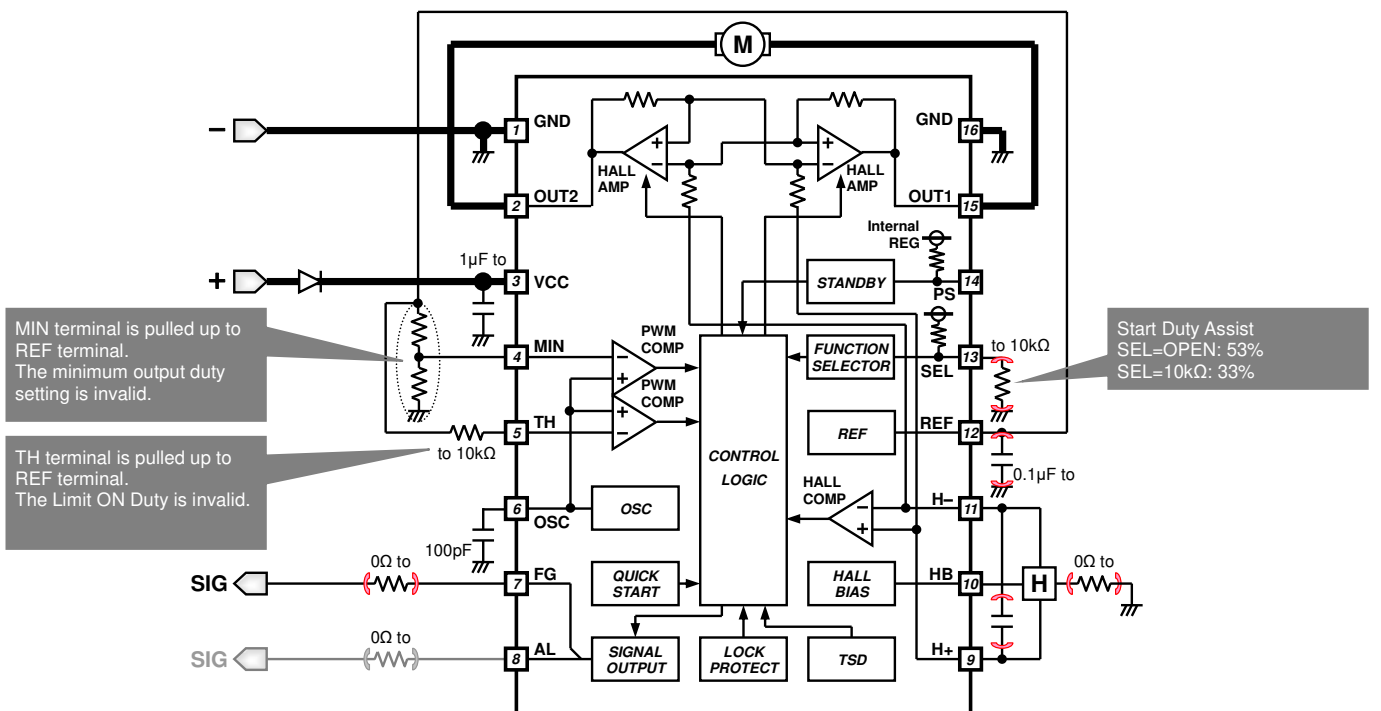

Figure 46. Application of DC Voltage Input 2

Application Circuit Example (Constant Values are for Reference)

4. DC Voltage Input Application 3 (Thermistor Control Application)

This is an example application circuit for controlling the rotational speed by ambient temperature. In this application, if the thermistor is OPEN, the IC operates at the set minimum rotational speed. Output duty changes depending on the TH voltage. Function of limit ON duty at start up can be set using the SEL terminal.

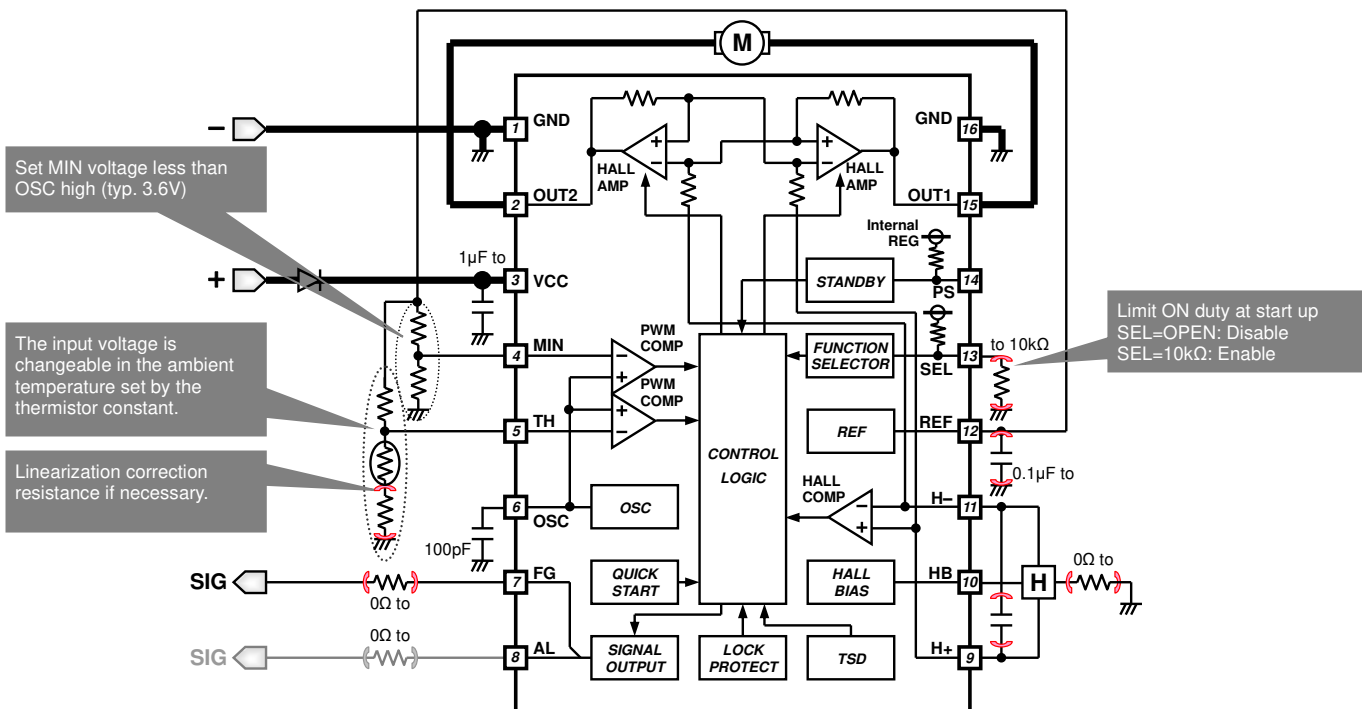

Figure 47. Application of Thermistor Control

5. Pulse Input Application (Use of stand-by function)

This is an example application circuit for inverting the external PWM input, and controlling the rotational speed. In this application, if the external PWM input is OPEN, the IC operates at the set maximum rotational speed. Minimum rotational speed cannot be set. The output duty changes depending on MIN. Function of Start Duty Assist can be set using the SEL terminal.

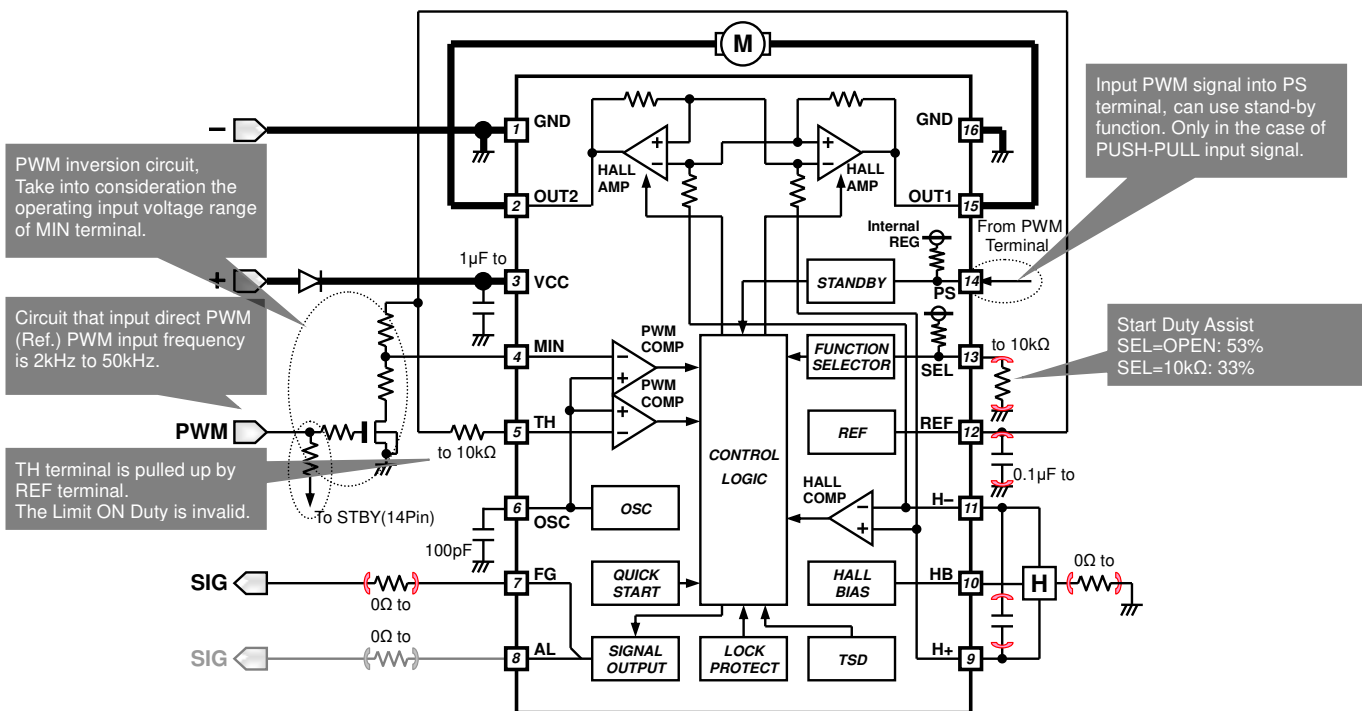

Figure 48. Application of Pulse Input

Functional Descriptions

1. Variable Speed Operation

The rotating speed changes by PWM duty on the motor outputs (OUT1, OUT2 terminals). PWM operation can be enabled by

- DC Voltage Input in TH Terminal, and MIN Terminal
- Pulse Input in MIN Terminal

(1) PWM Operation by DC Input

As shown in Figure 51, to change motor output ON duty, DC voltage input from TH terminal is compared with triangle wave produced by internal OSC circuit. MIN terminal is for setting the minimum rotating speed. ON duty is determined by either TH terminal voltage or MIN terminal, whichever is lower.

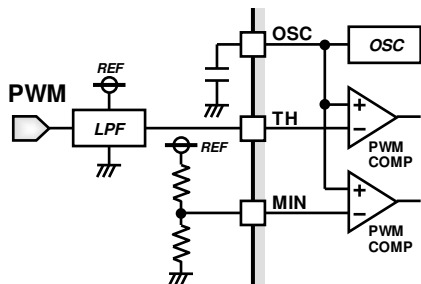

Figure 49. DC Input Application 1

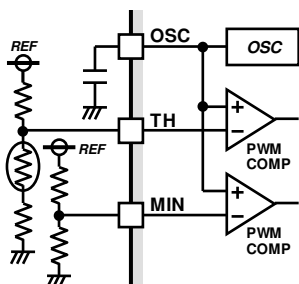

Figure 50. DC Input Application 2

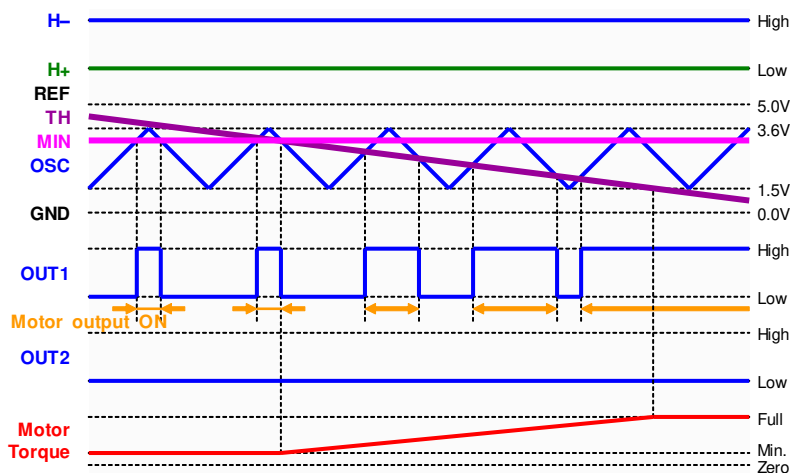

Figure 51. DC Input Operation Timing Chart

Dividing resistance of the internal regulator generates OSC high level (typ. 3.6V) and OSC low level (typ. 1.5V) voltage, and the ratio of those voltages is designed to be hard to fluctuate. When the input voltage at TH terminal is constant, effect by fluctuation of OSC H/L voltage is large. However, by setting that an application of REF voltage generates input voltage via TH, application can be made hard to be affected by voltage fluctuation of triangle wave. For an application that requires strict precision, determine a value with sufficient margin after taking full consideration of external constants.

(2) PWM Operation by Pulse Input

Pulse signal can be input to MIN terminal for PWM operation as shown in Figure 53. The ON duty of the output changes by the cycle of the input pulse signal. The TH terminal is pulled-up in the REF terminal.

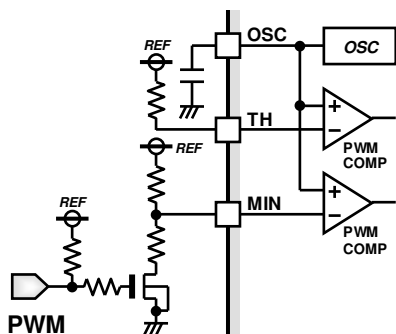

Figure 52. Pulse Input Application

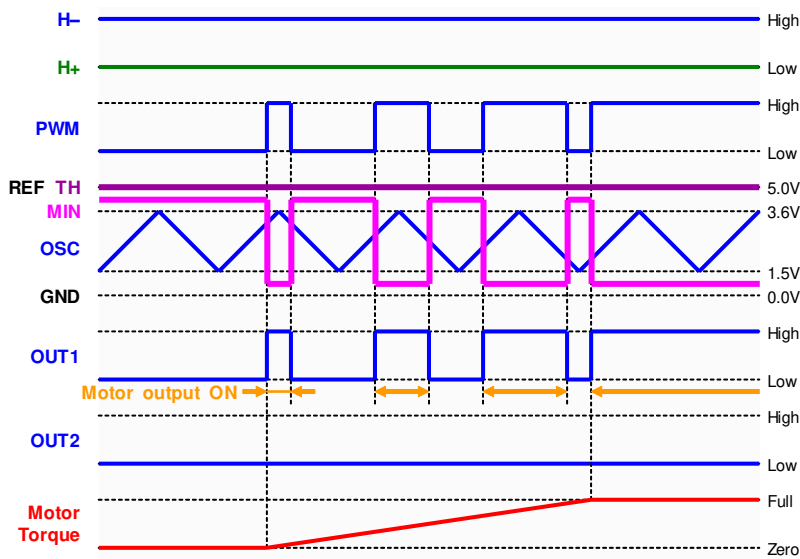

Figure 53. Pulse Input Operation Timing Chart

Functional Descriptions

1. Variable Speed Operation – Continued

(3) Setting of TH and MIN Terminals

The voltage of the TH terminal or MIN terminal becomes irregular when it is open. Please apply voltages to both terminals when you turn on IC power supply (V_{CC}).

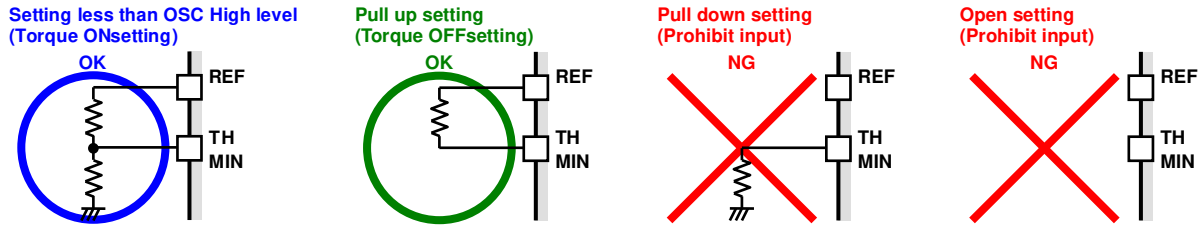

Figure 54. Setting of the Variable Speed Function

(4) Output Oscillatory Frequency Setting

Frequency (f_{osc}) in which the motor outputs are operated PWM by DC voltage input is set according to capacity value (C_{osc}) of the capacitor connected with OSC terminal.

$$f_{osc} = |I_{dosc} \times I_{cosc}| / (C_{osc} \times (|I_{dosc}| + |I_{cosc}|) \times (V_{osch} - V_{oscl})) \text{ [Hz]} \text{ (Equation 1)}$$

- f_{osc}: OSC Frequency [Hz]
- C_{osc}: OSC Capacitance [F]
- I_{dosc}: OSC Discharge current [A] (Typ 11μA)
- I_{cosc}: OSC Charge current [A] (Typ -11μA)
- V_{osch}: OSC High voltage [V] (Typ 3.6V)
- V_{oscl}: OSC Low voltage [V] (Typ 1.5V)

(ex.) The frequency when motor output PWM operates becomes about 26.2 kHz when assuming that C_{osc} is 100pF.

$$f_{osc} = |11 \times 10^{-6} \times -11 \times 10^{-6}| / (100 \times 10^{-12} \times (|11 \times 10^{-6}| + |-11 \times 10^{-6}|) \times (3.6 - 1.5)) = 26.2 \times 10^3 \text{ [Hz]} \text{ (Equation2)}$$

2. Limit ON Duty at Start-up and Function Selector

(1) Limit ON Duty at Start-up

In the application circuit of speed control by DC voltage input, Limit ON Duty at start up function can reduce the rush current of the motor. It is driven by a constant output duty (D_{oHL}; Typ 53%) within a given period of time (t_{oHL}; Typ 0.5s). When SEL is LOW (pull-down to GND using R<10kΩ) and TH voltage is less than 3.6V (Typ), Limit ON Duty at start up operates under the following conditions:

- (a) Power ON
- (b) Quick Start
- (c) Lock release, Lock detection ON time(T_{ON})
- (d) Standby release

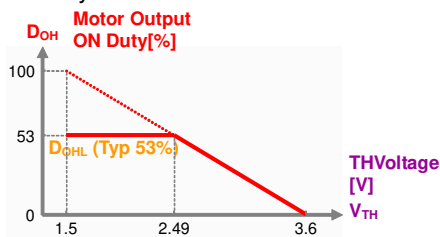

Figure 55. Characteristic of Limit ON Duty at Start-up

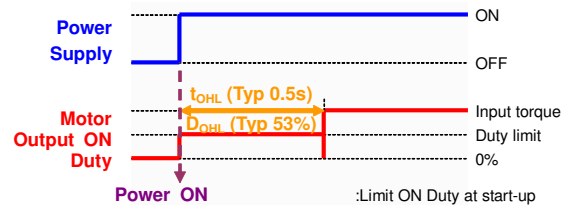

Figure 56. Timing Chart of Power ON

(2) Function Selector of Limit ON Duty

Function of Limit ON duty at start up can be set (Disable or Enable) using the SEL terminal.

Please refer to the timing chart (Figure 56, 61, 62) for each function.

- (a) SEL = OPEN (pull up to internal REG); Limit ON Duty at Start-up Disable
- (b) SEL = Low (pull down to GND using R<10kΩ); Limit ON Duty at Start-up Enable

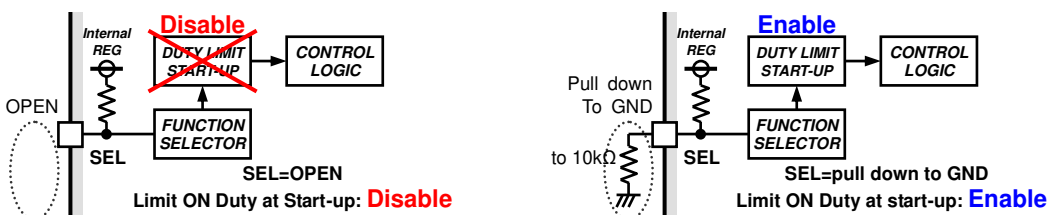

Figure 57. Select Function in the DC Voltage Input Application

Functional Descriptions

3. Start Duty Assist and Duty Selector

(1) Start Duty Assist

In the application circuit of speed control by pulse input, Start Duty Assist can secure a constant starting torque even at low duty. The IC is driven by a constant output duty (D_{OHS1} ; Typ 33% or D_{OHS2} ; Typ 53%) within a given period of time (Typ 0.25s). When TH voltage more than REF-0.1V and MIN voltage is less than 3.6V (Typ), Start Duty Assist function operates under the following conditions:

- (a) Power ON
- (b) Quick Start
- (c) Lock release, Lock detection ON time (T_{on})
- (d) Standby release

When the motor rotates, this function is released even if in this time.

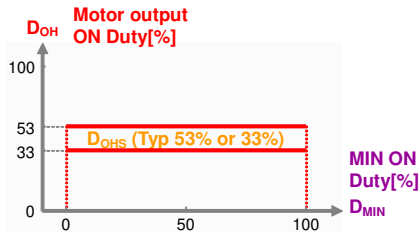

Figure 58. Characteristic of Start Duty Assist

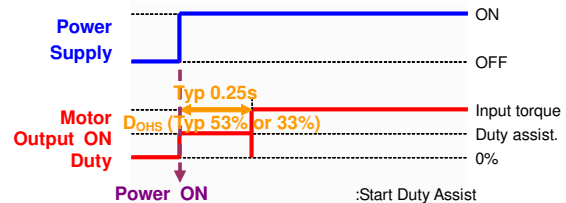

Figure 59. Timing Chart of Power ON

(2) Duty Selector of Start Duty Assist

Function of Start Duty Assist can be set to either 53% or 33% using the SEL terminal. Please refer to the timing chart (Figure 59, 62, 63) for each function.

- (a) SEL = OPEN (pull up to internal REG); Duty 53%
- (b) SEL = Low (pull down to GND using $R < 10k\Omega$); Duty 33%

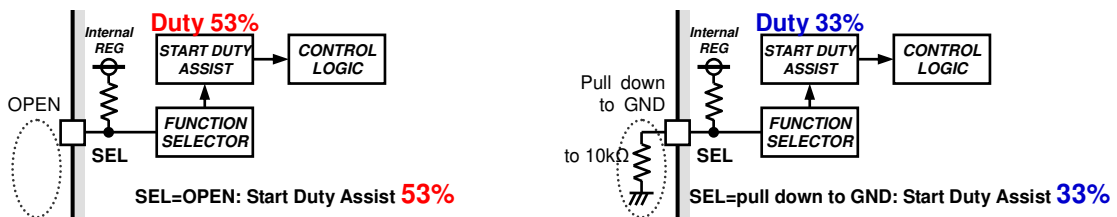

Figure 60. Duty Select in the Pulse Input Application

(3) Relation with Limit ON Duty Function

As shown in Table 1, the function changes depending on the setting of SEL terminal and the two speed control applications.

Table 1. Speed Control Application and SEL Terminal Setting

Speed Control Application	SEL Terminal	
	OPEN	10kΩ pull down to GND
DC Voltage Input ($TH < REF - 0.5V$)	Limit ON Duty : Disable	Limit ON Duty : Enable
Pulse Input ($TH > REF - 0.1V$)	Start Duty Assist : 53%	Start Duty Assist : 33%

Functional Descriptions

4. Quick Start

When torque off logic is input by the control signal over a fixed time (1.0ms), the lock protection function is disabled. The motor can restart quickly once the control signal is applied.

Lock alarm signal (AL) at the time of the Quick Start maintains the logic of the AL signal just before the Quick Start standby. But when AL signal begins Quick Start standby in Hi-Z and a hall input signal is replaced during Quick Start standby later, AL signal is changed to L from H.

The lock protection function doesn't work with an input frequency slower than 1 kHz assuming high level duty = 100% of the MIN input signal. Input signal frequency must be faster than 2 kHz.

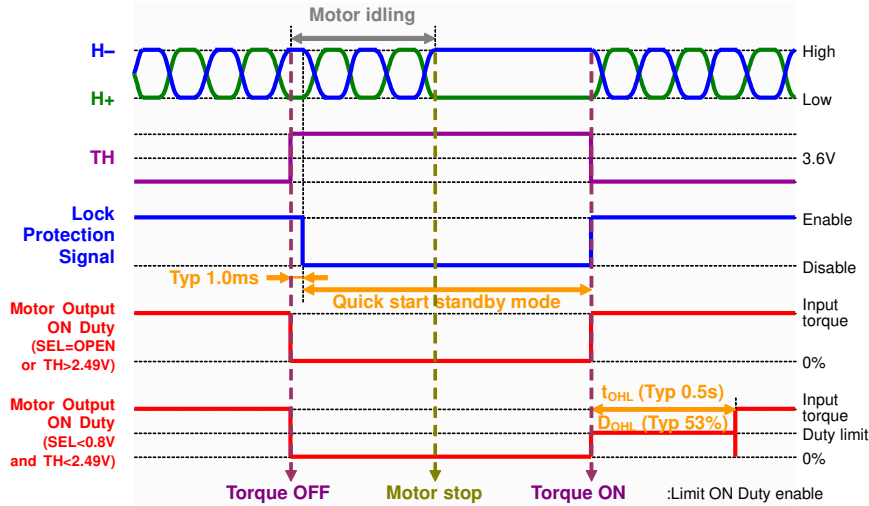

Figure 61. Quick Start Timing Chart (DC Input Application)

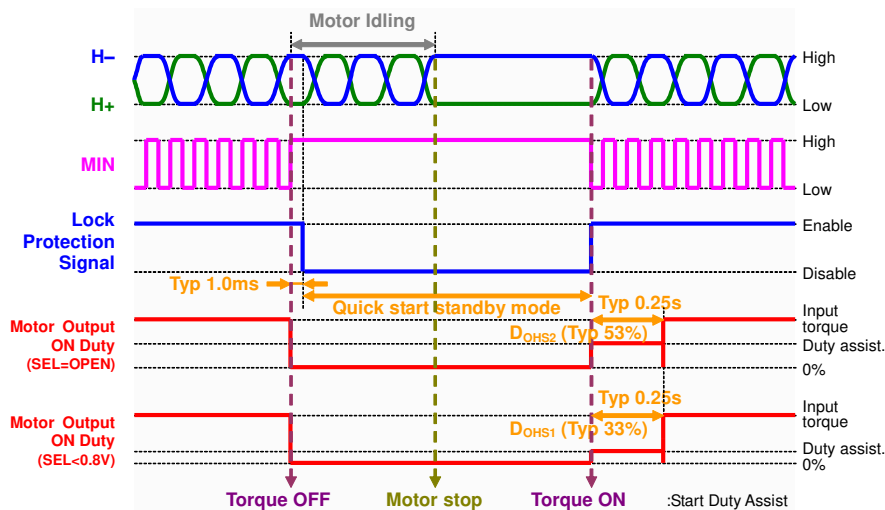

Figure 62. Quick Start Timing Chart (Pulse Input Application)

Functional Descriptions

5. Lock Protection and Automatic Restart

Motor rotation is detected by hall signal and the IC internal counter set lock detection ON time (TON) and OFF time (TOFF). Timing chart is shown in Figure 63.

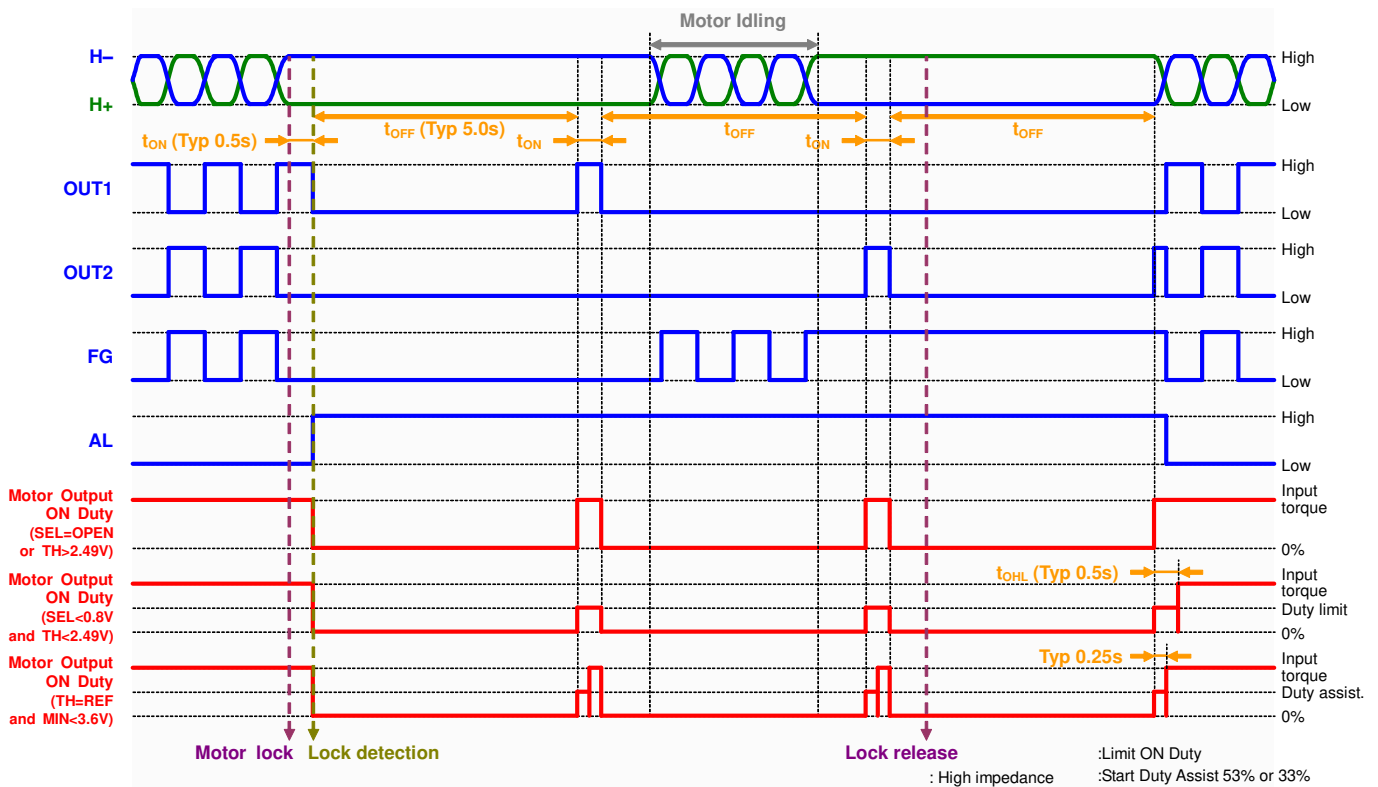

Figure 63. Lock Protection (Incorporated Counter System) Timing Chart

6. Hall Input Setting

(1) Hall Input Setting

Hall input voltage range is shown in operating conditions (P.1). Adjust the value of hall element bias resistor R1 in Figure 65 so that the input voltage of a hall element is input in "hall input voltage range" including signal amplitude.

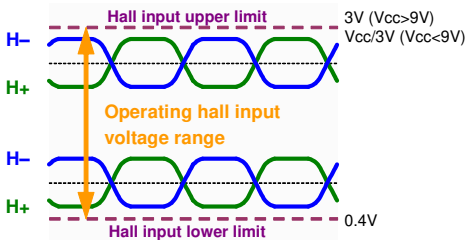

Figure 64. Hall Input Voltage Range

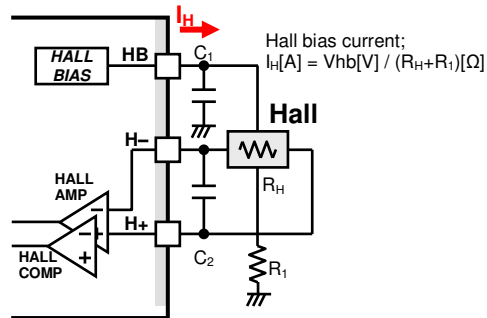

Figure 65. Hall Input Application

(2) Reducing the Noise of Hall Signal

VCC noise or the like depending on the wiring pattern of board may affect Hall element. In this case, place a capacitor like C1 in Figure 65. In addition, when wiring from the hall element output to IC hall input is long, noise may be loaded on wiring. In this case, place a capacitor like C2.

Functional Descriptions

7. BTL Soft Switching Function (Silent Drive Setting)

(1) Motor Output Slope by the Hall Input Amplitude

Input signal to hall amplifier (H+, H-) is amplified to produce an output signal (OUT1, OUT2). When the hall element amplitude is small, the slope of the output waveform is gentle. When it is large, the slope of the output waveform is steep. Gain of 48.5dB (270 times) is provided between input and output, therefore, an appropriate hall element input signal must be applied to the IC such that output waveform swings. An input of more than 150mVpp (Hall amplitude difference conversion) is recommended.

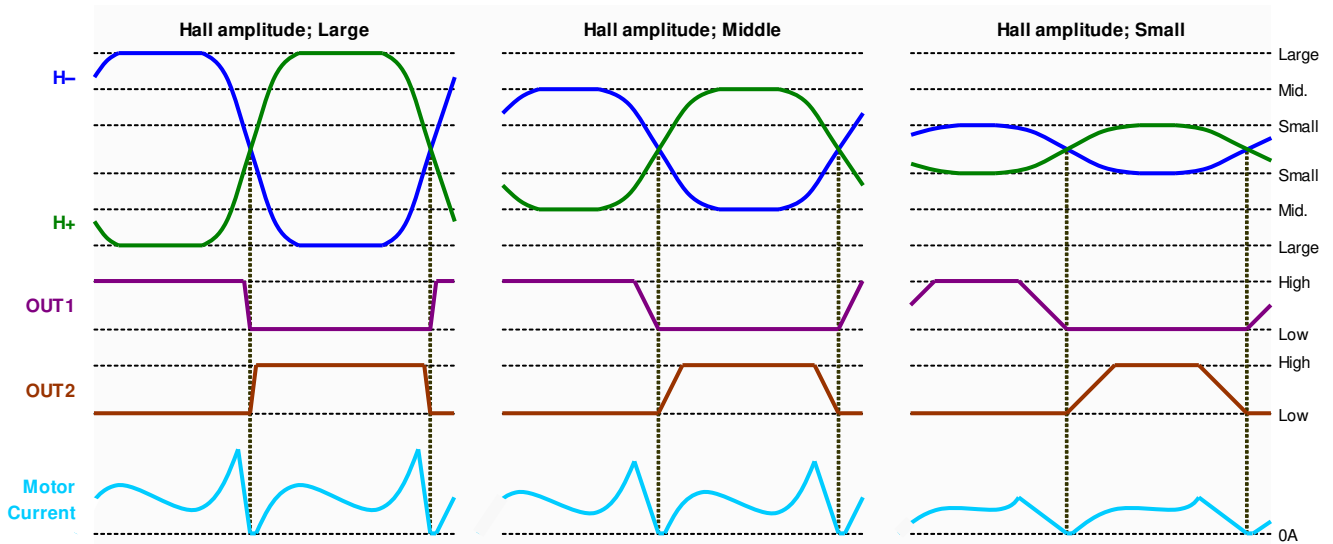

Figure 66. Hall Input Amplitude and the Motor Output Waveform

(2) Drive System at DC Voltage Input

At the speed controlled by the DC voltage input to TH terminal, BD6994FV automatically adjusts the regeneration section during phase change of output depending on TH voltage. As a result, the motor becomes closer to H bridge drive at high speed rotation, and contributes to lower power consumption

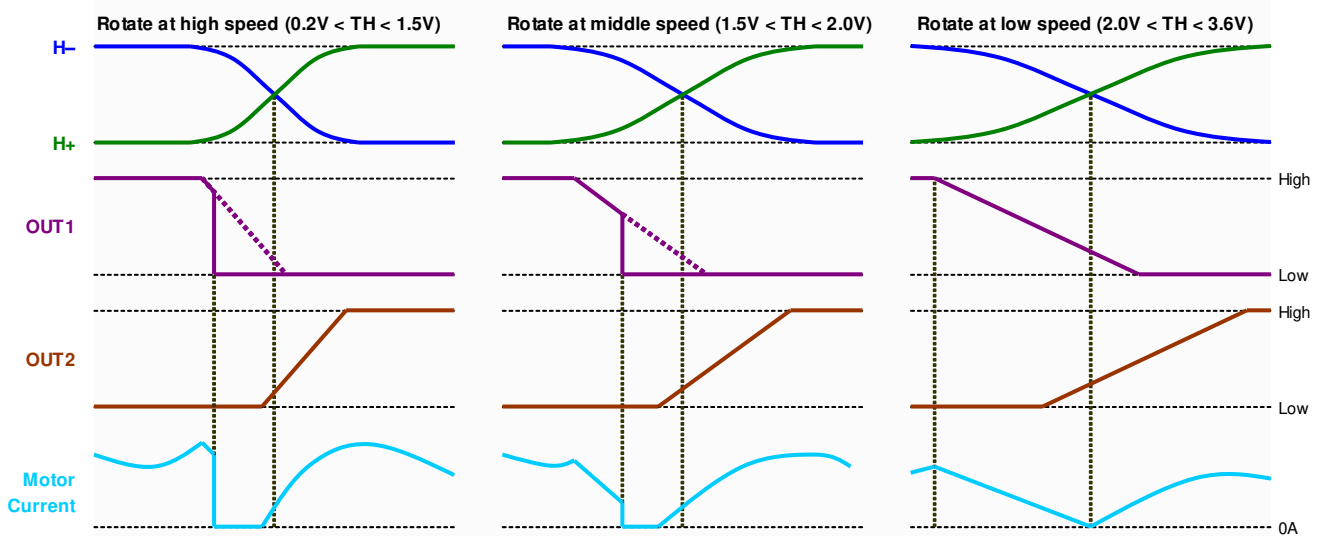

Figure 67. TH Voltage and Motor Output Waveform (PWM by the TH voltage is Omitted for a Functional Description)

Functional Descriptions

8. Stand-by

When L logic of PS pin is input by the control signal over a fixed time (1.0ms), the IC will be in stand-by mode.
 In stand-by mode, AL signal becomes L logic and FG signal becomes Hi-Z logic.
 When H logic of PS pin is input by the control signal, the IC is in normal drive mode.
 When AL pin is not used in stand-by mode, the motor current becomes 160uA ($V_{CC}=12V, Typ$).

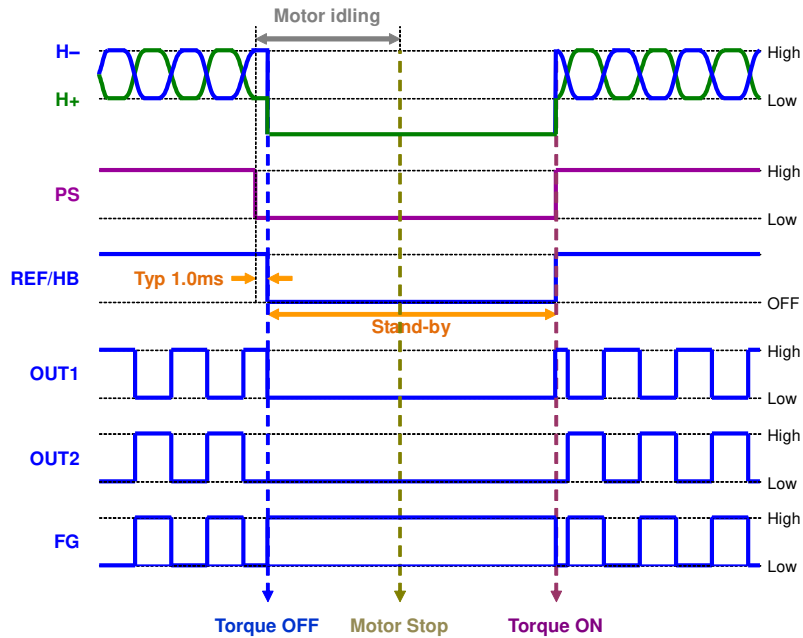

Figure 68. Stand-by Timing Chart

When PS pin is used like in the application circuit example, use PUSH-PULL PWM signal input. PWM signal input of the open Drain / Collector cannot be used. Because internal resistance (200kΩ: pull up to internal REG) is high, using open Drain / Corrector is not enough for speed of H input.

Safety Measure

1. Reverse Connection Protection Diode

Reverse connection of power results in IC destruction as shown in Figure 69. When reverse connection is possible, reverse connection protection diode must be added between power supply and VCC.

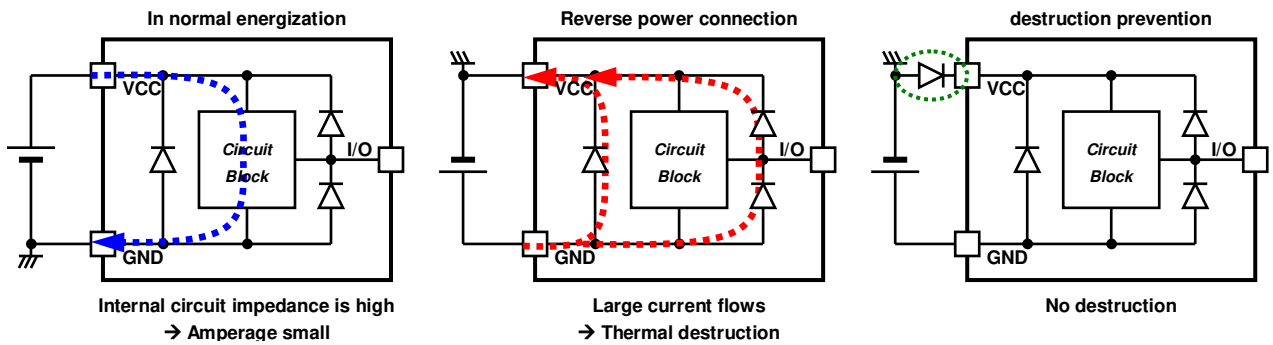

Figure 69. Flow of Current When Power is Connected Reversely

2. Measure against V_{CC} Voltage Rise by Back Electromotive Force

Back electromotive force (Back EMF) generates regenerative current to power supply. However, when reverse connection protection diode is connected, V_{CC} voltage rises because the diode prevents current flow to power supply.

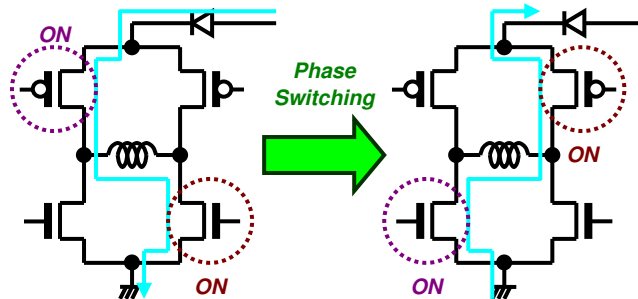

Figure 70. VCC Voltage Rise by Back Electromotive Force

When the absolute maximum rated voltage may be exceeded due to voltage rise by back electromotive force, place (A) Capacitor or (B) Zener diode between VCC and GND. If necessary, add both (C).

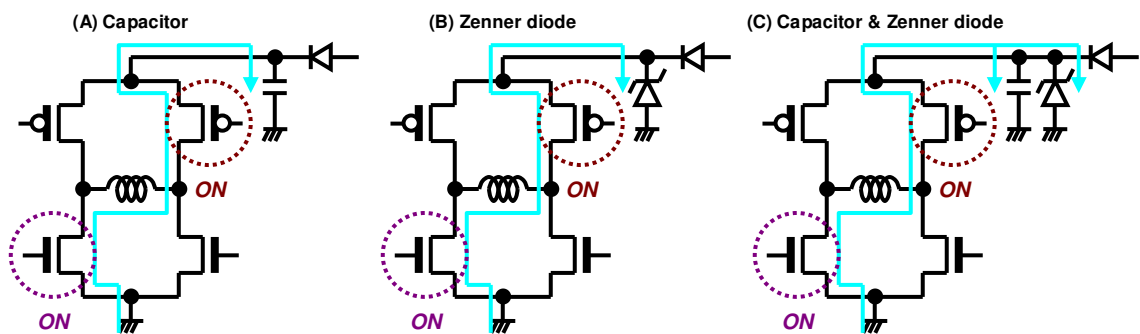

Figure 71. Measure against Vcc and Motor Driving Outputs Voltage

3. Problem of GND line PWM Switching

Do not perform PWM switching of GND line because GND terminal potential cannot be kept to a minimum.

4. Protection of Rotation Speed Pulse (FG) and/or Lock Alarm (AL) Open-Drain Output

FG and/or AL output is an open drain and requires pull-up resistor. Adding resistor can protect the IC. Exceeding the absolute maximum rating, when FG and/or AL terminal is directly connected to power supply, could damage the IC.

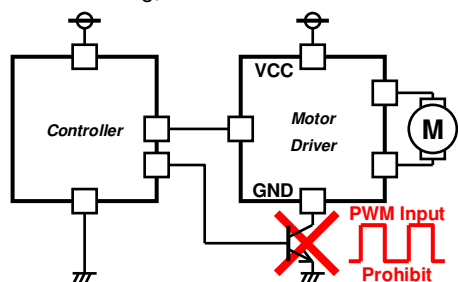

Figure 72. GND Line PWM Switching Prohibited

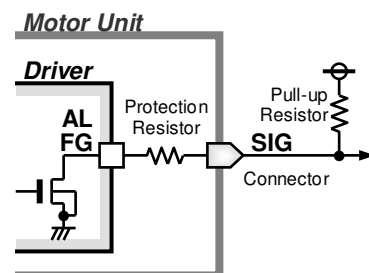

Figure 73. Protection of FG/AL Terminal

Power Consumption

1. Current Pathway

The current pathways that relates to driver IC are the following, and shown in Figure 74.

- (1) Circuit Current (I_{CC})
- (2) Motor Driving Current (I_M)
- (3) Reference Bias Current to the LPF and Resistors (I_{REF})
- (4) Hall Bias Current to the Hall Element (I_{HB})
- (5) FG(AL) Output Sink Current (I_{SO})

2. Calculation of Power Consumption

- (1) Circuit Current (I_{CC})
 $P_{W(a)} = V_{CC} \times I_{CC}$ [W] (Equation3)

$P_{W(a)}$: Power consumption [W]
 V_{CC} : V_{CC} voltage [V]
 I_{CC} : Circuit current [A]
 (Expect hall bias current (I_{HB}))

- (2) Motor Driving Current (I_M)
 $P_{W(b)} = ((V_{OH} + V_{OL}) \times I_M) \times T_2 / T_1 + (I_{CHANGE} / 2 \times V_{CC} / 4) \times T_3 / T_1$ [W] (Equation4)

$P_{W(b)}$: Power consumption [W]
 V_{OH} : Output high voltage [V]
 V_{OL} : Output low voltage [V]
 I_M : Motor driving average current [A]
 I_{CHANGE} : Motor driving current of BTL initiation [A]

- (3) Reference Bias Current to the LPF and Resistors (I_{REF})
 $P_{W(c)} = (V_{CC} - V_{REF}) \times I_{REF}$ [W] (Equation5)

$P_{W(c)}$: Power consumption [W]
 V_{REF} : REF voltage [V]
 I_{REF} : REF bias current [A]

- (4) Hall Bias Current to the Hall Element (I_{HB})
 $P_{W(d)} = (V_{CC} - V_{HB}) \times I_{HB}$ [W] (Equation6)

$P_{W(d)}$: Power consumption [W]
 V_{HB} : Hall bias voltage [V]
 I_{HB} : Hall bias current [A]

- (5) FG(AL) Output Sink Current (I_{SO})
 $P_{W(e)} = V_{SO} \times I_{SO}$ [W] (Equation7)

$P_{W(e)}$: Power consumption [W]
 V_{SO} : FG(AL) output low voltage [V]
 I_{SO} : FG(AL) output sink current [A]

Total power consumption of driver IC becomes the following by the above (1) to (5).

$P_{W(ttl)} = P_{W(a)} + P_{W(b)} + P_{W(c)} + P_{W(d)} + P_{W(e)}$ [W] (Equation8)

(ex.)

$P_{W(a)} = 12 \times 6.5 \times 10^{-3}$ [W] (Equation9)
 $P_{W(b)} = ((0.37 + 0.23) \times 0.4) \times 9/10 + (0.4/2 \times 12/4) \times 1/10$ [W] (Equation10)
 $P_{W(c)} = (12 - 5.1) \times 2.0 \times 10^{-3}$ [W] (Equation11)
 $P_{W(d)} = (12 - 1.25) \times 3.5 \times 10^{-3}$ [W] (Equation12)
 $P_{W(e)} = 0.2 \times 5.0 \times 10^{-3}$ [W] (Equation13)
 $P_{W(ttl)} = 0.406$ [W] (Equation14)

Refer to next page when you calculate the chip surface temperature (T_j) and the package surface temperature (T_c) by using the power consumption value.

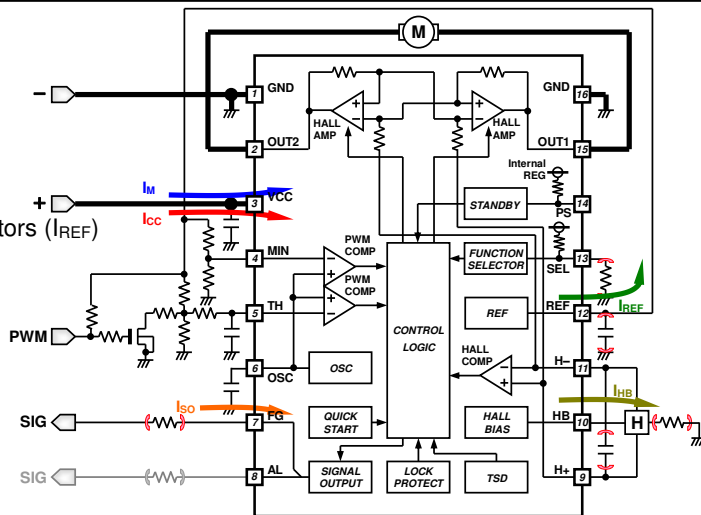

Figure 74. Current Pathway of IC

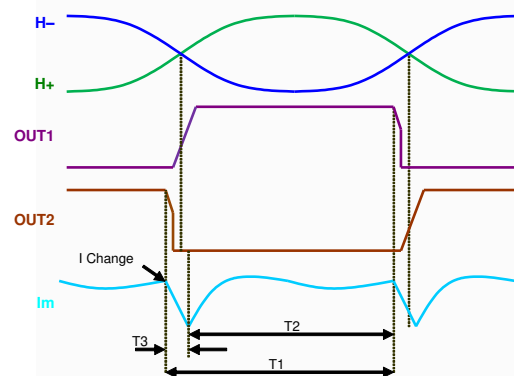

Figure 75. Motor Driving Current for calculation

Power Dissipation

1. Power Dissipation

Power dissipation (total loss) indicates the power that can be consumed by IC at Ta=25°C (normal temperature). IC is heated when it consumes power, and the temperature of IC chip becomes higher than ambient temperature. The temperature that can be accepted by IC chip into the package, that is junction temperature of the absolute maximum rating, depends on circuit configuration, manufacturing process, etc. Power dissipation is determined by this maximum joint temperature, the thermal resistance in the state of the substrate mounting, and the ambient temperature.

Therefore, when a power dissipation exceeds the absolute maximum rating, the operating temperature range is not a guarantee. The maximum junction temperature is in general equal to the maximum value in the storage temperature range.

2. Thermal Resistance

Heat generated by consumed power of IC is radiated from the mold resin or lead frame of package. The parameter which indicates this heat dissipation capability (hardness of heat release) is called thermal resistance. In the state of the substrate mounting, thermal resistances from the chip junction to the ambience and to the package surface are shown respectively with θ_{ja} [°C/W] and θ_{jc} [°C/W]. Thermal resistance is classified into the package part and the substrate part, and thermal resistance in the package part depends on the composition materials such as the mold resins and the lead frames. On the other hand, thermal resistance in the substrate part depends on the substrate heat dissipation capability of the material, the size, and the copper foil area etc. Therefore, thermal resistance can be decreased by the heat radiation measures like installing a heat sink etc. in the mounting substrate.

The thermal resistance model and calculations are shown in Figure 76, and Equation 15 and 16, respectively.

$$\theta_{ja} = (T_j - T_a) / P \text{ [°C/W]} \text{ (Equation 15)}$$

$$\theta_{jc} = (T_j - T_c) / P \text{ [°C/W]} \text{ (Equation 16)}$$

where:

θ_{ja} is the thermal resistance from the chip junction to the ambience

θ_{jc} is the thermal resistance from the chip junction to the package surface

Tj is the junction temperature

Ta is the ambient temperature

Tc is the package surface temperature

P is the power consumption

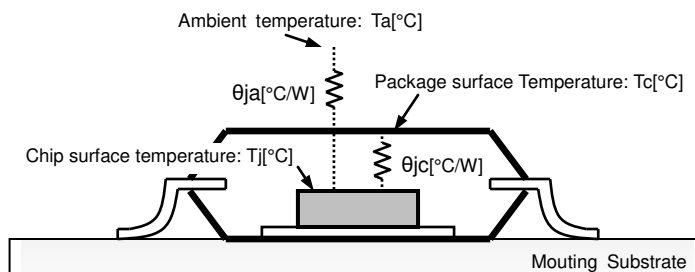

Figure 76. Thermal Resistance Model of Surface Mount

Even if it uses the same package, thermal resistance θ_{ja} and θ_{jc} are changed depending on the chip size, power consumption, and the measurement environments of the ambient temperature, the mounting condition, and the wind velocity, etc. Thermal resistance under a certain regulated condition is shown in Table 2 as a reference data when the FR4 glass epoxy substrate (70mm x 70mm x 1.6mm and 3% or less in the area of the copper foil) is mounted.

Table 2. Thermal Resistance (Reference Data)

Rohm Standard (Note 1)	One-layer	Unit
θ_{ja}	142.9	°C/W
θ_{jc}	36	°C/W

(Note 1) Mounted on 70.0mm x 70.0mm x 1.6mm glass epoxy board

3. Thermal De-rating Curve

Thermal de-rating curve indicates power that can be consumed by IC with reference to ambient temperature. Power that can be consumed by IC begins to attenuate at certain ambient temperature (25°C), and becomes 0W at the maximum joint temperature (150°C). The inclination is reduced by the reciprocal of thermal resistance θ_{ja} . The thermal de-rating curve under a certain regulated condition is shown in Figure 77.

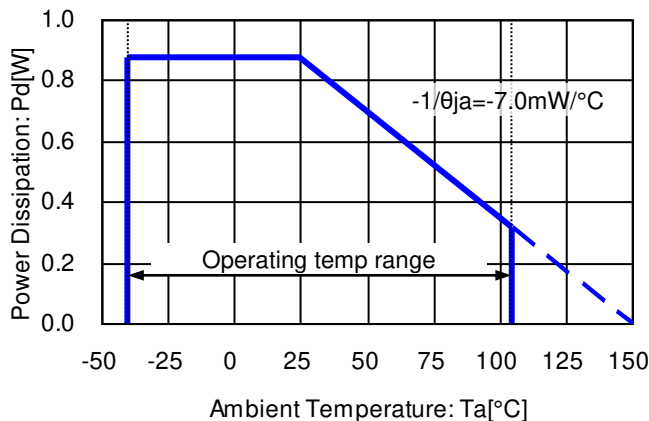
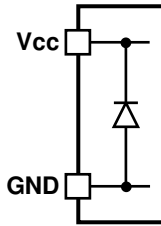

Figure 77. Power Dissipation vs Ambient Temperature (Mounted on 70.0mm x 70.0mm x 1.6mm glass epoxy)

I/O Equivalence Circuit (Resistance Values are Typical)

1. Power supply terminal, and Ground terminal



2. Hall input terminals, Output duty controllable input pin, and Minimum output duty setting pin

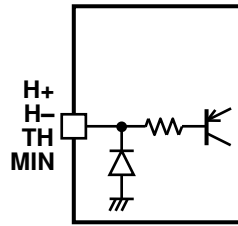

3. Motor output pins

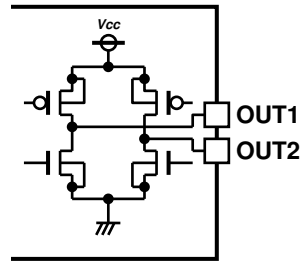

4. Reference voltage output and Hall bias pin

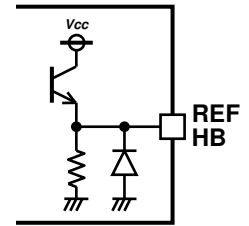

5. Duty control start up function setting pin

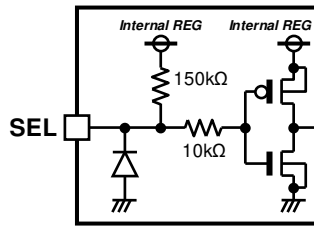

6. Oscillating capacitor connecting pin

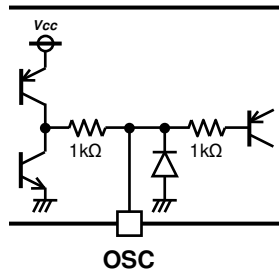

7. Speed pulse signal output pin and Lock alarm signal output pin

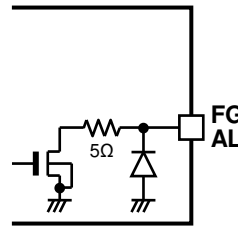

8. Power Save pin

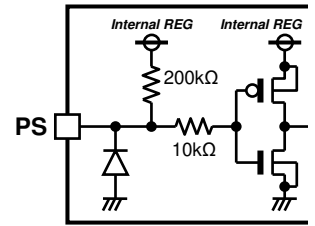

Operational Notes

1. Reverse Connection of Power Supply
Connecting the power supply in reverse polarity can damage the IC. Take precautions against reverse polarity when connecting the power supply, such as mounting an external diode between the power supply and the IC's power supply pins.
2. Power Supply Lines
Design the PCB layout pattern to provide low impedance supply lines. Separate the ground and supply lines of the digital and analog blocks to prevent noise in the ground and supply lines of the digital block from affecting the analog block furthermore, connect a capacitor to ground at all power supply pins. Consider the effect of temperature and aging on the capacitance value when using electrolytic capacitors.
3. Ground Voltage
Ensure that no pins are at a voltage below that of the ground pin at any time, even during transient condition. However, pins that drive inductive loads (e.g. motor driver outputs, DC-DC converter outputs) may inevitably go below ground due to back EMF or electromotive force. In such cases, the user should make sure that such voltages going below ground will not cause the IC and the system to malfunction by examining carefully all relevant factors and conditions such as motor characteristics, supply voltage, operating frequency and PCB wiring to name a few.
4. Ground Wiring Pattern
When using both small-signal and large-current ground traces, the two ground traces should be routed separately but connected to a single ground at the reference point of the application board to avoid fluctuations in the small-signal ground caused by large currents. Also ensure that the ground traces of external components do not cause variations on the ground voltage the ground lines must be as short and thick as possible to reduce line impedance.
5. Thermal Consideration
Should by any chance the power dissipation rating be exceeded the rise in temperature of the chip may result in deterioration of the properties of the chip. The absolute maximum rating of the power dissipation stated in this datasheet is when the IC is mounted on a 70mm x 70mm x 1.6mm glass epoxy board. In case of exceeding this absolute maximum rating, increase the board size and copper area to raise heat dissipation capability.
6. Recommended Operating Conditions
These conditions represent a range within which the expected characteristics of the IC can be approximately obtained. The electrical characteristics are guaranteed under the conditions of each parameter.
7. Inrush Current
When power is first supplied to the IC, it is possible that the internal logic may be unstable and inrush current may flow instantaneously due to the internal powering sequence and delays, especially if the IC has more than one power supply. Therefore, give special consideration to power coupling capacitance, width of power and ground wiring, and routing of connections.
8. Operation Under Strong Electromagnetic Field
Operating the IC in the presence of a strong electromagnetic field may cause the IC to malfunction.
9. Testing on Application Boards
When testing the IC on an application board, connecting a capacitor directly to a low-impedance output pin may subject the IC to stress. Always discharge capacitors completely after each process or step. To prevent damage from static discharge, ground the IC during assembly and use similar precautions during transport and storage. The IC's power supply should always be turned off completely before connecting or removing it from the test setup during the inspection process.
10. Mounting Errors and Inter-pin Short
Ensure that the direction and position are correct when mounting the IC on the PCB. Incorrect mounting may result in damaging the IC. Avoid nearby pins being shorted to each other especially to ground, power supply and output pin. Inter-pin shorts could be due to many reasons such as metal particles, water droplets (in very humid environment) and unintentional solder bridge deposited in between pins during assembly to name a few.

Operational Notes

11. Unused Input Pins

Input pins of an IC are often connected to the gate of a MOS transistor. The gate has extremely high impedance and extremely low capacitance. If left unconnected, the electric field from the outside can easily charge it. The small charge acquired in this way is enough to produce a significant effect on the conduction through the transistor and cause unexpected operation of the IC. Especially, if it is not expressed on the datasheet, unused input pins should be connected to the power supply or ground line.

12. Regarding the Input Pin of the IC

This monolithic IC contains P+ isolation and P substrate layers between adjacent elements in order to keep them isolated. P-N junctions are formed at the intersection of the P layers with the N layers of other elements, creating a parasitic diode or transistor. For example (refer to figure below):

When $GND > Pin A$ and $GND > Pin B$, the P-N junction operates as a parasitic diode.

When $GND > Pin B$, the P-N junction operates as a parasitic transistor.

Parasitic diodes inevitably occur in the structure of the IC. The operation of parasitic diodes can result in mutual interference among circuits, operational faults, or physical damage. Therefore, conditions that cause these diodes to operate, such as applying a voltage lower than the GND voltage to an input pin (and thus to the P substrate) should be avoided.

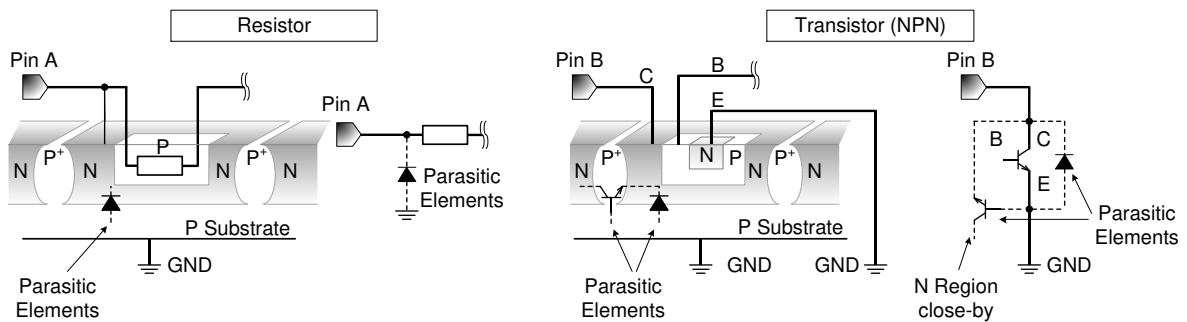

Figure 78. Example of Monolithic IC Structure

13. Ceramic Capacitor

When using a ceramic capacitor, determine the dielectric constant considering the change of capacitance with temperature and the decrease in nominal capacitance due to DC bias and others.

14. Area of Safe Operation (ASO)

Operate the IC such that the output voltage, output current, and power dissipation are all within the Area of Safe Operation (ASO).

15. Thermal Shutdown (TSD) Circuit

This IC has a built-in thermal shutdown circuit that prevents heat damage to the IC. Normal operation should always be within the IC's power dissipation rating. If however the rating is exceeded for a continued period, the junction temperature will rise which will activate the TSD circuit that will turn OFF all output pins. When the junction temperature falls below the TSD threshold, the circuits are automatically restored to normal operation.

Note that the TSD circuit operates in a situation that exceeds the absolute maximum ratings and therefore, under no circumstances, should the TSD circuit be used in a set design or for any purpose other than protecting the IC from heat damage.

Physical Dimension, Tape and Reel Information

Package Name	SSOP-B16
--------------	----------

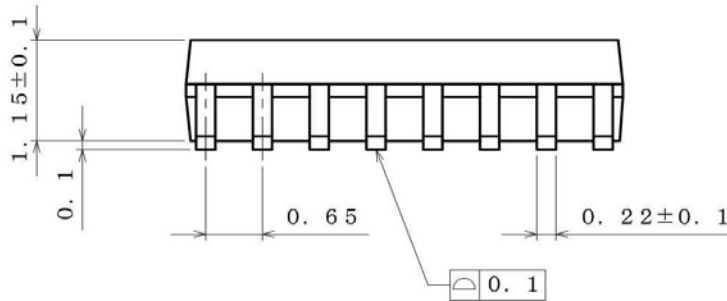
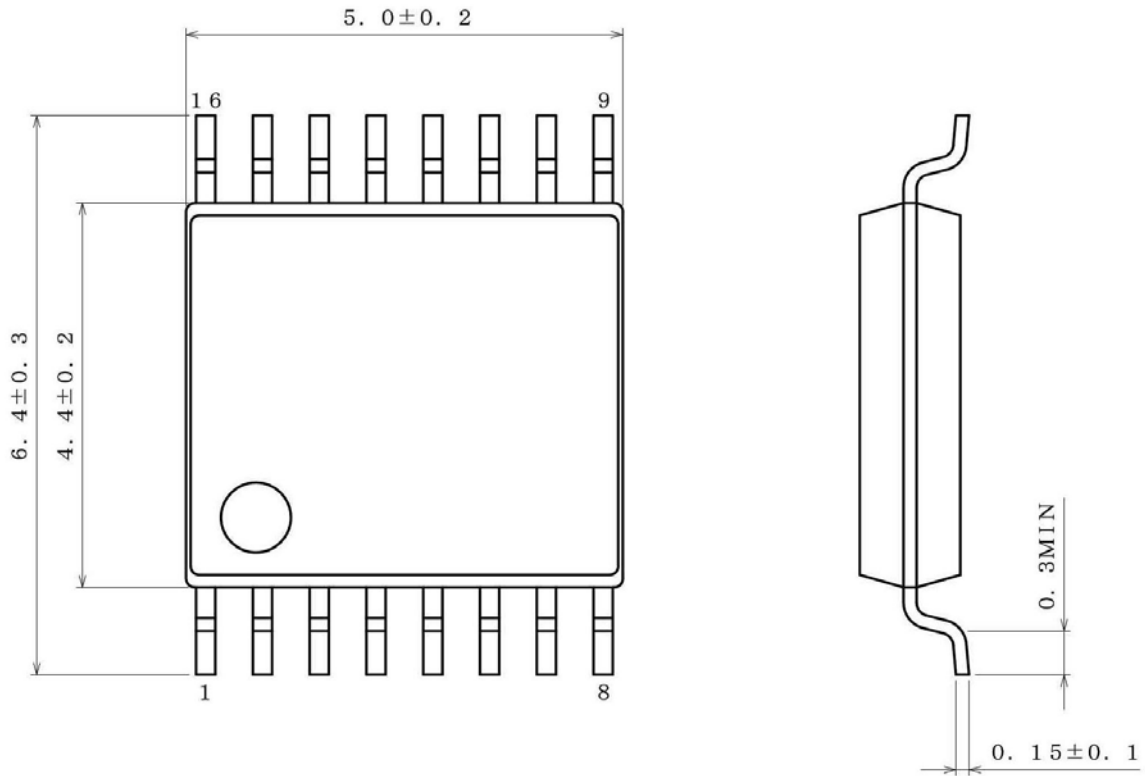

(UNIT : mm)
 PKG : SSOP-B16
 Drawing No. B0771

<Tape and Reel information>

Tape	Embossed carrier tape
Quantity	2500pcs
Direction of feed	E2 (The direction is the 1pin of product is at the upper left when you hold reel on the left hand and you pull out the tape on the right hand)

Reel

1pin

Direction of feed

*Order quantity needs to be multiple of the minimum quantity.

Ordering Information

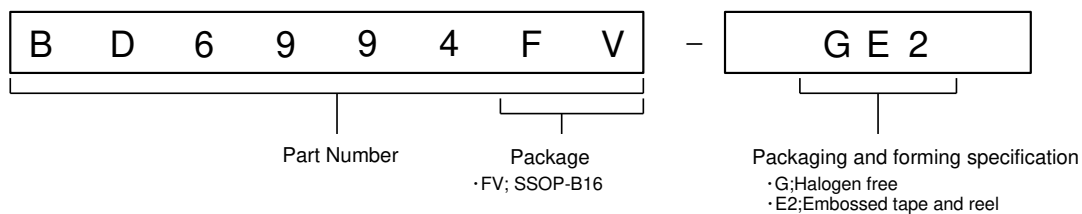

Marking Diagram

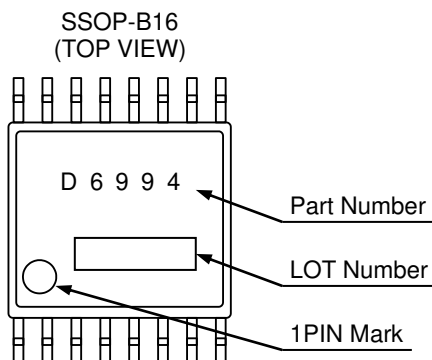

Revision History

Date	Revision	Comments
18.May.2015	001	New Release
13.Jul.2015	002	Change of Ordering Information
31.Mar.2021	003	Updated packages and part numbers P.31-2, P31-3

Ordering Information

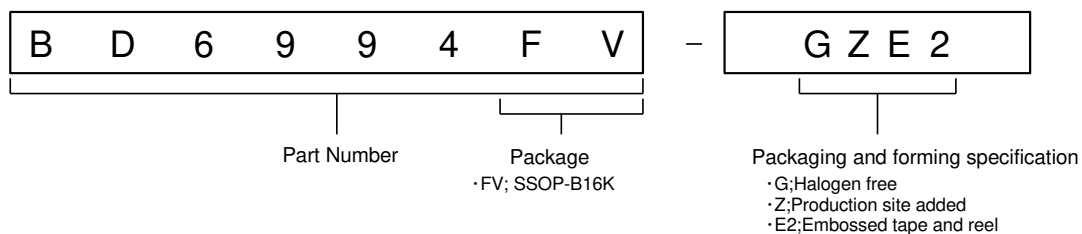

Marking Diagram

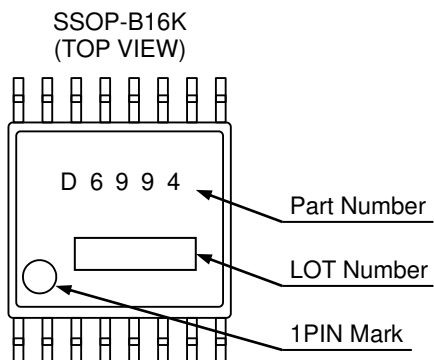

Physical Dimension and Packing Information

Package Name	SSOP-B16K
--------------	-----------

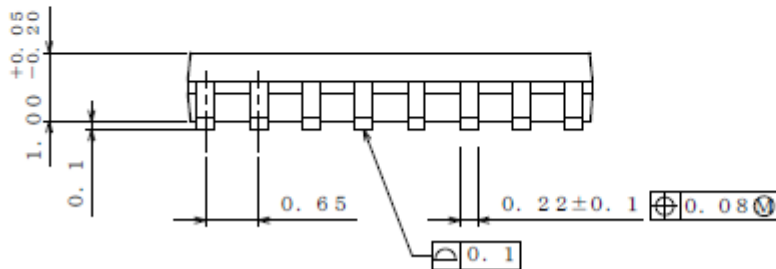
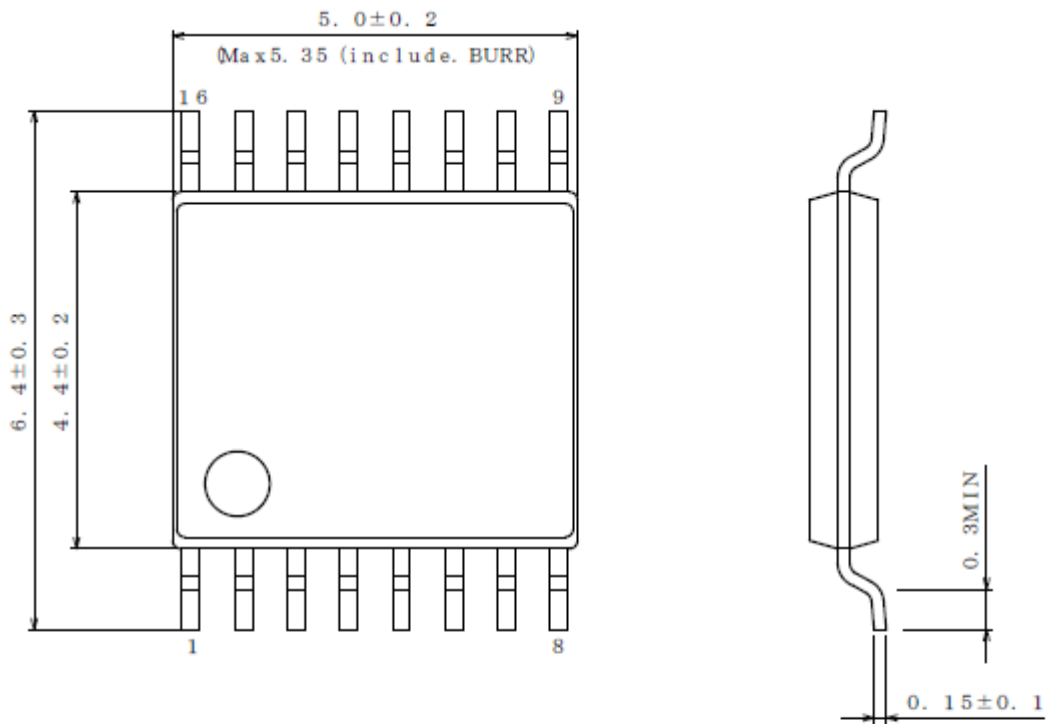

(UNIT : mm)
 PKG : SSOP-B16K
 Drawing No. EX001-0103

< Tape and Reel Information >

Tape	Embossed carrier tape
Quantity	2500pcs
Direction of feed	E2 The direction is the pin 1 of product is at the upper left when you hold reel on the left hand and you pull out the tape on the right hand

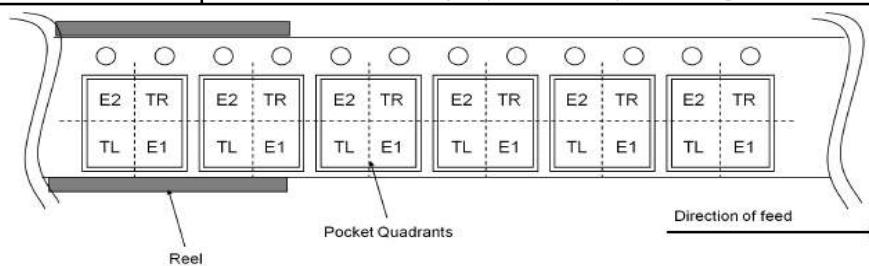

Notice

Precaution on using ROHM Products

- Our Products are designed and manufactured for application in ordinary electronic equipment (such as AV equipment, OA equipment, telecommunication equipment, home electronic appliances, amusement equipment, etc.). If you intend to use our Products in devices requiring extremely high reliability (such as medical equipment ^(Note 1), transport equipment, traffic equipment, aircraft/spacecraft, nuclear power controllers, fuel controllers, car equipment including car accessories, safety devices, etc.) and whose malfunction or failure may cause loss of human life, bodily injury or serious damage to property ("Specific Applications"), please consult with the ROHM sales representative in advance. Unless otherwise agreed in writing by ROHM in advance, ROHM shall not be in any way responsible or liable for any damages, expenses or losses incurred by you or third parties arising from the use of any ROHM's Products for Specific Applications.

(Note1) Medical Equipment Classification of the Specific Applications

JAPAN	USA	EU	CHINA
CLASS III	CLASS III	CLASS II b	CLASS III
CLASS IV		CLASS III	

- ROHM designs and manufactures its Products subject to strict quality control system. However, semiconductor products can fail or malfunction at a certain rate. Please be sure to implement, at your own responsibilities, adequate safety measures including but not limited to fail-safe design against the physical injury, damage to any property, which a failure or malfunction of our Products may cause. The following are examples of safety measures:
 - Installation of protection circuits or other protective devices to improve system safety
 - Installation of redundant circuits to reduce the impact of single or multiple circuit failure
- Our Products are designed and manufactured for use under standard conditions and not under any special or extraordinary environments or conditions, as exemplified below. Accordingly, ROHM shall not be in any way responsible or liable for any damages, expenses or losses arising from the use of any ROHM's Products under any special or extraordinary environments or conditions. If you intend to use our Products under any special or extraordinary environments or conditions (as exemplified below), your independent verification and confirmation of product performance, reliability, etc. prior to use, must be necessary:
 - Use of our Products in any types of liquid, including water, oils, chemicals, and organic solvents
 - Use of our Products outdoors or in places where the Products are exposed to direct sunlight or dust
 - Use of our Products in places where the Products are exposed to sea wind or corrosive gases, including Cl₂, H₂S, NH₃, SO₂, and NO₂
 - Use of our Products in places where the Products are exposed to static electricity or electromagnetic waves
 - Use of our Products in proximity to heat-producing components, plastic cords, or other flammable items
 - Sealing or coating our Products with resin or other coating materials
 - Use of our Products without cleaning residue of flux (Exclude cases where no-clean type fluxes is used. However, recommend sufficiently about the residue.) ; or Washing our Products by using water or water-soluble cleaning agents for cleaning residue after soldering
 - Use of the Products in places subject to dew condensation
- The Products are not subject to radiation-proof design.
- Please verify and confirm characteristics of the final or mounted products in using the Products.
- In particular, if a transient load (a large amount of load applied in a short period of time, such as pulse, is applied, confirmation of performance characteristics after on-board mounting is strongly recommended. Avoid applying power exceeding normal rated power; exceeding the power rating under steady-state loading condition may negatively affect product performance and reliability.
- De-rate Power Dissipation depending on ambient temperature. When used in sealed area, confirm that it is the use in the range that does not exceed the maximum junction temperature.
- Confirm that operation temperature is within the specified range described in the product specification.
- ROHM shall not be in any way responsible or liable for failure induced under deviant condition from what is defined in this document.

Precaution for Mounting / Circuit board design

- When a highly active halogenous (chlorine, bromine, etc.) flux is used, the residue of flux may negatively affect product performance and reliability.
- In principle, the reflow soldering method must be used on a surface-mount products, the flow soldering method must be used on a through hole mount products. If the flow soldering method is preferred on a surface-mount products, please consult with the ROHM representative in advance.

For details, please refer to ROHM Mounting specification

Precautions Regarding Application Examples and External Circuits

1. If change is made to the constant of an external circuit, please allow a sufficient margin considering variations of the characteristics of the Products and external components, including transient characteristics, as well as static characteristics.
2. You agree that application notes, reference designs, and associated data and information contained in this document are presented only as guidance for Products use. Therefore, in case you use such information, you are solely responsible for it and you must exercise your own independent verification and judgment in the use of such information contained in this document. ROHM shall not be in any way responsible or liable for any damages, expenses or losses incurred by you or third parties arising from the use of such information.

Precaution for Electrostatic

This Product is electrostatic sensitive product, which may be damaged due to electrostatic discharge. Please take proper caution in your manufacturing process and storage so that voltage exceeding the Products maximum rating will not be applied to Products. Please take special care under dry condition (e.g. Grounding of human body / equipment / solder iron, isolation from charged objects, setting of ionizer, friction prevention and temperature / humidity control).

Precaution for Storage / Transportation

1. Product performance and soldered connections may deteriorate if the Products are stored in the places where:
 - [a] the Products are exposed to sea winds or corrosive gases, including Cl₂, H₂S, NH₃, SO₂, and NO₂
 - [b] the temperature or humidity exceeds those recommended by ROHM
 - [c] the Products are exposed to direct sunshine or condensation
 - [d] the Products are exposed to high Electrostatic
2. Even under ROHM recommended storage condition, solderability of products out of recommended storage time period may be degraded. It is strongly recommended to confirm solderability before using Products of which storage time is exceeding the recommended storage time period.
3. Store / transport cartons in the correct direction, which is indicated on a carton with a symbol. Otherwise bent leads may occur due to excessive stress applied when dropping of a carton.
4. Use Products within the specified time after opening a humidity barrier bag. Baking is required before using Products of which storage time is exceeding the recommended storage time period.

Precaution for Product Label

A two-dimensional barcode printed on ROHM Products label is for ROHM's internal use only.

Precaution for Disposition

When disposing Products please dispose them properly using an authorized industry waste company.

Precaution for Foreign Exchange and Foreign Trade act

Since concerned goods might be fallen under listed items of export control prescribed by Foreign exchange and Foreign trade act, please consult with ROHM in case of export.

Precaution Regarding Intellectual Property Rights

1. All information and data including but not limited to application example contained in this document is for reference only. ROHM does not warrant that foregoing information or data will not infringe any intellectual property rights or any other rights of any third party regarding such information or data.
2. ROHM shall not have any obligations where the claims, actions or demands arising from the combination of the Products with other articles such as components, circuits, systems or external equipment (including software).
3. No license, expressly or implied, is granted hereby under any intellectual property rights or other rights of ROHM or any third parties with respect to the Products or the information contained in this document. Provided, however, that ROHM will not assert its intellectual property rights or other rights against you or your customers to the extent necessary to manufacture or sell products containing the Products, subject to the terms and conditions herein.

Other Precaution

1. This document may not be reprinted or reproduced, in whole or in part, without prior written consent of ROHM.
2. The Products may not be disassembled, converted, modified, reproduced or otherwise changed without prior written consent of ROHM.
3. In no event shall you use in any way whatsoever the Products and the related technical information contained in the Products or this document for any military purposes, including but not limited to, the development of mass-destruction weapons.
4. The proper names of companies or products described in this document are trademarks or registered trademarks of ROHM, its affiliated companies or third parties.

General Precaution

1. Before you use our Products, you are requested to carefully read this document and fully understand its contents. ROHM shall not be in any way responsible or liable for failure, malfunction or accident arising from the use of any ROHM's Products against warning, caution or note contained in this document.
2. All information contained in this document is current as of the issuing date and subject to change without any prior notice. Before purchasing or using ROHM's Products, please confirm the latest information with a ROHM sales representative.
3. The information contained in this document is provided on an "as is" basis and ROHM does not warrant that all information contained in this document is accurate and/or error-free. ROHM shall not be in any way responsible or liable for any damages, expenses or losses incurred by you or third parties resulting from inaccuracy or errors of or concerning such information.