

REVISIONS				
P.	LTN	DESCRIPTION	DATE	OWN APVD
C2		REVISED PER ECO-18-002347	14FEB2018	KP GK
C3		REVISED PER ECO-18-005108	03APR2018	JMS GK
C4		REVISED PER ECO-19-009349	21JUN2019	JMS HC
C5		REVISED PER ECO-21-002920	03MAR2021	CN HC

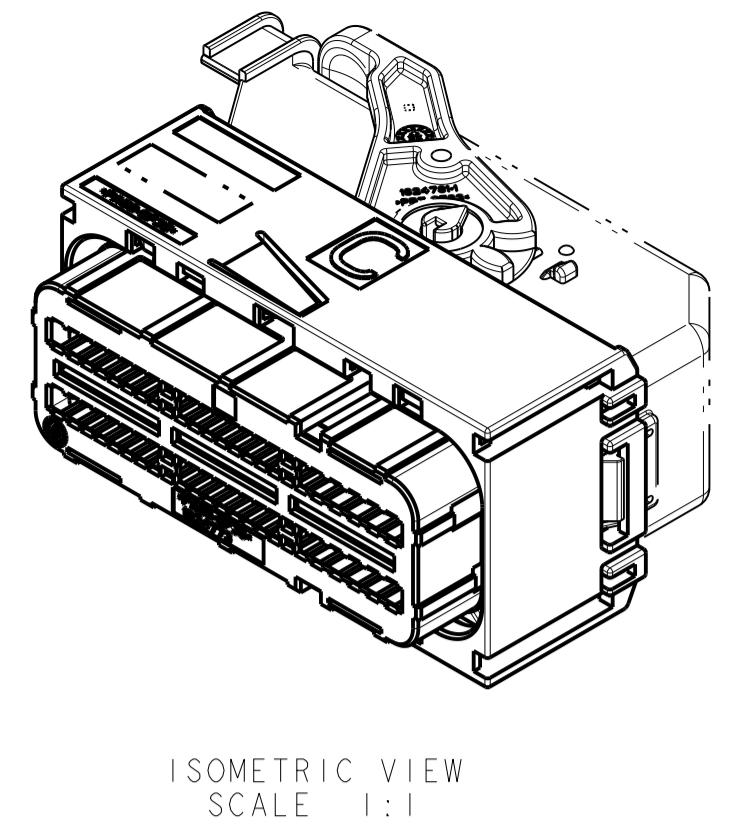

LEFT EXIT PLUG ASSEMBLY SHOWN WITH OPTIONAL WIRE COVER ASSEMBLY (MUST BE PURCHASED SEPARATELY) SCALE 1:1

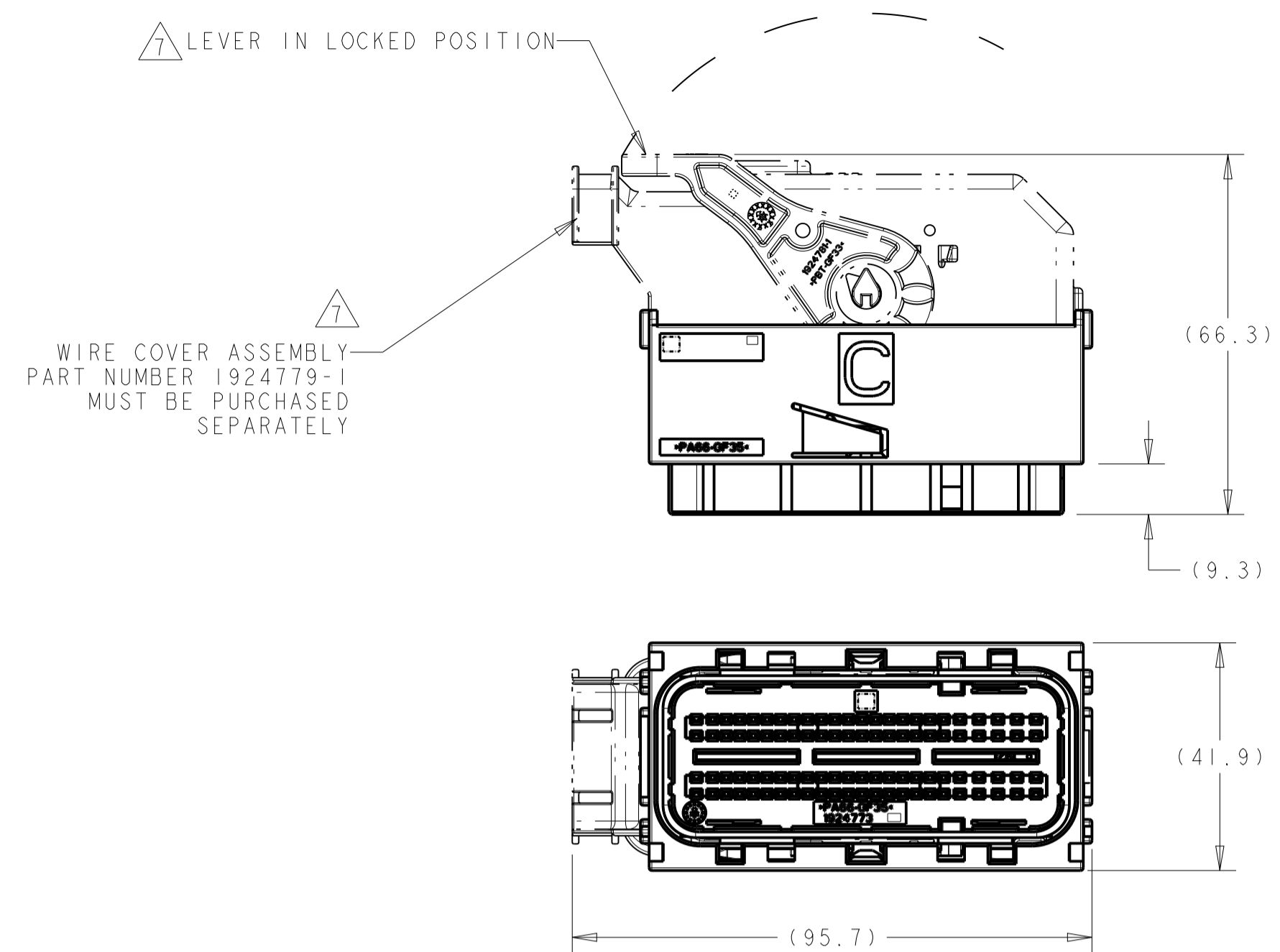
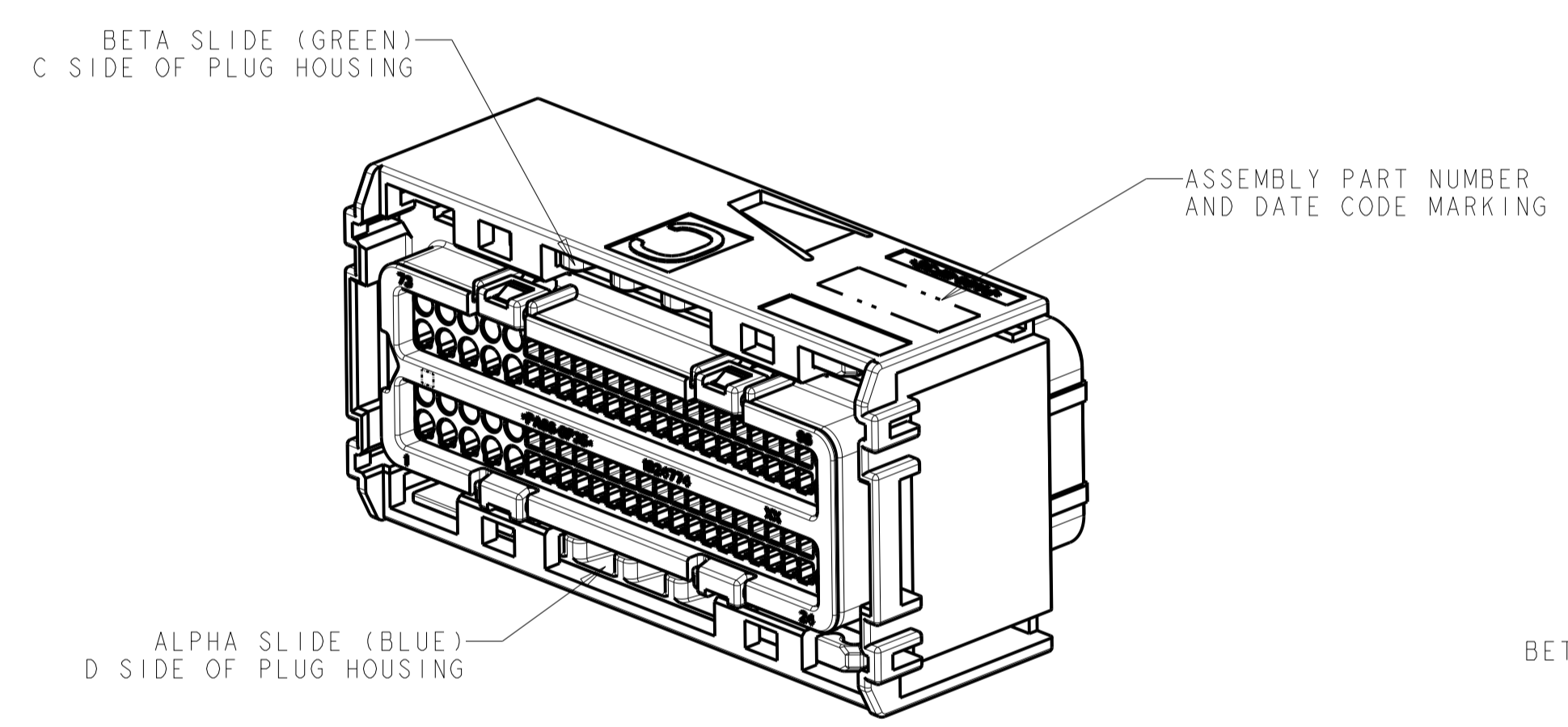
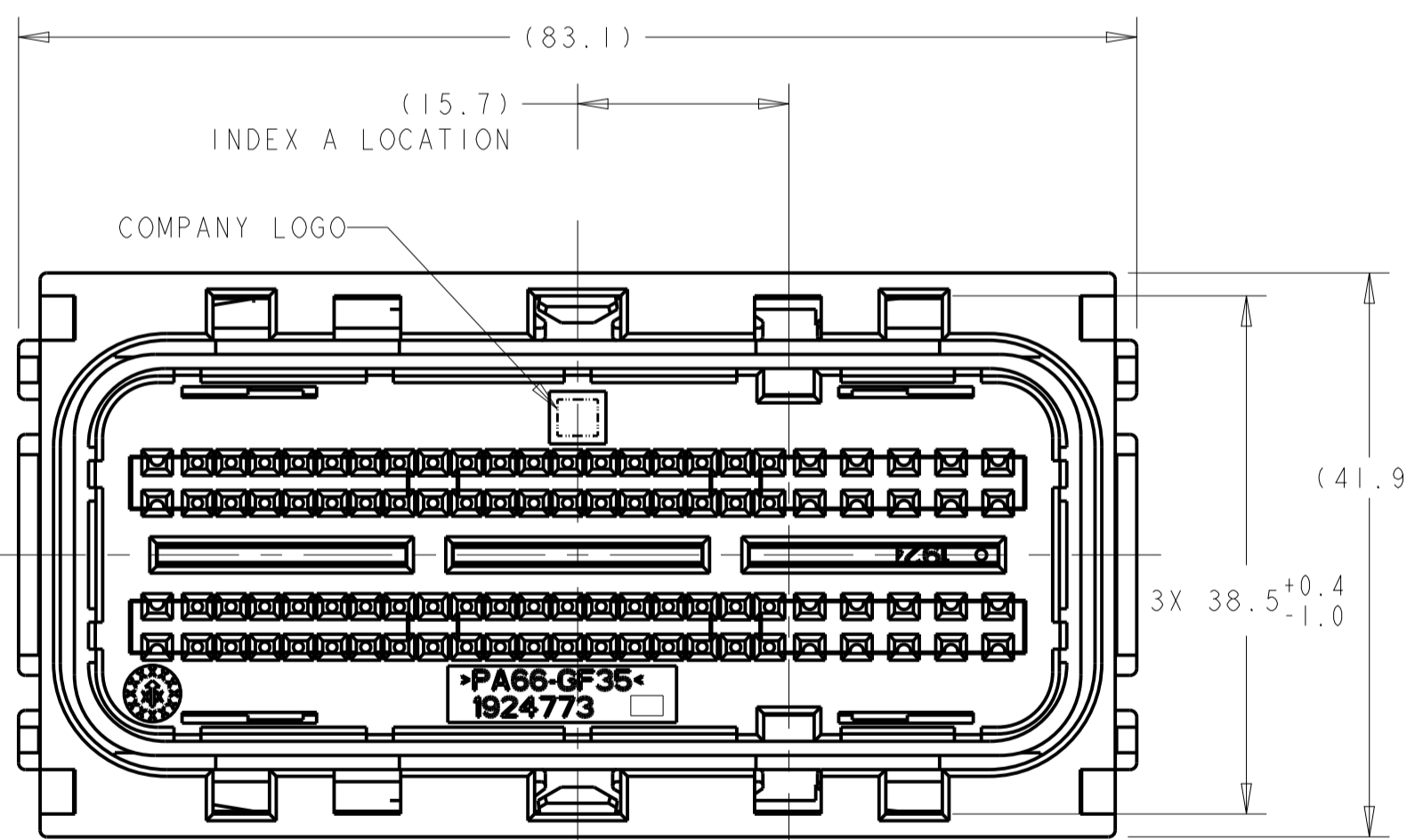
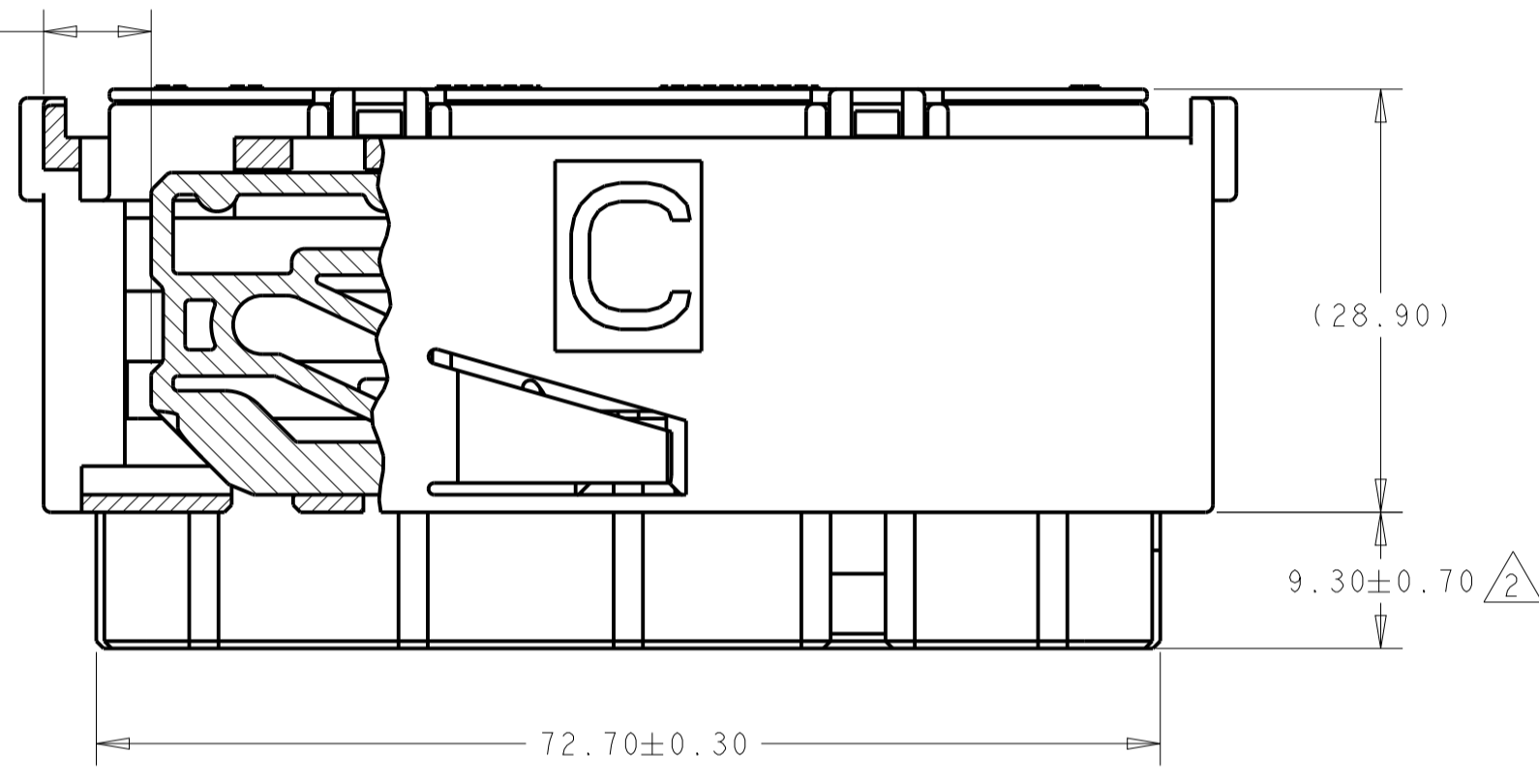
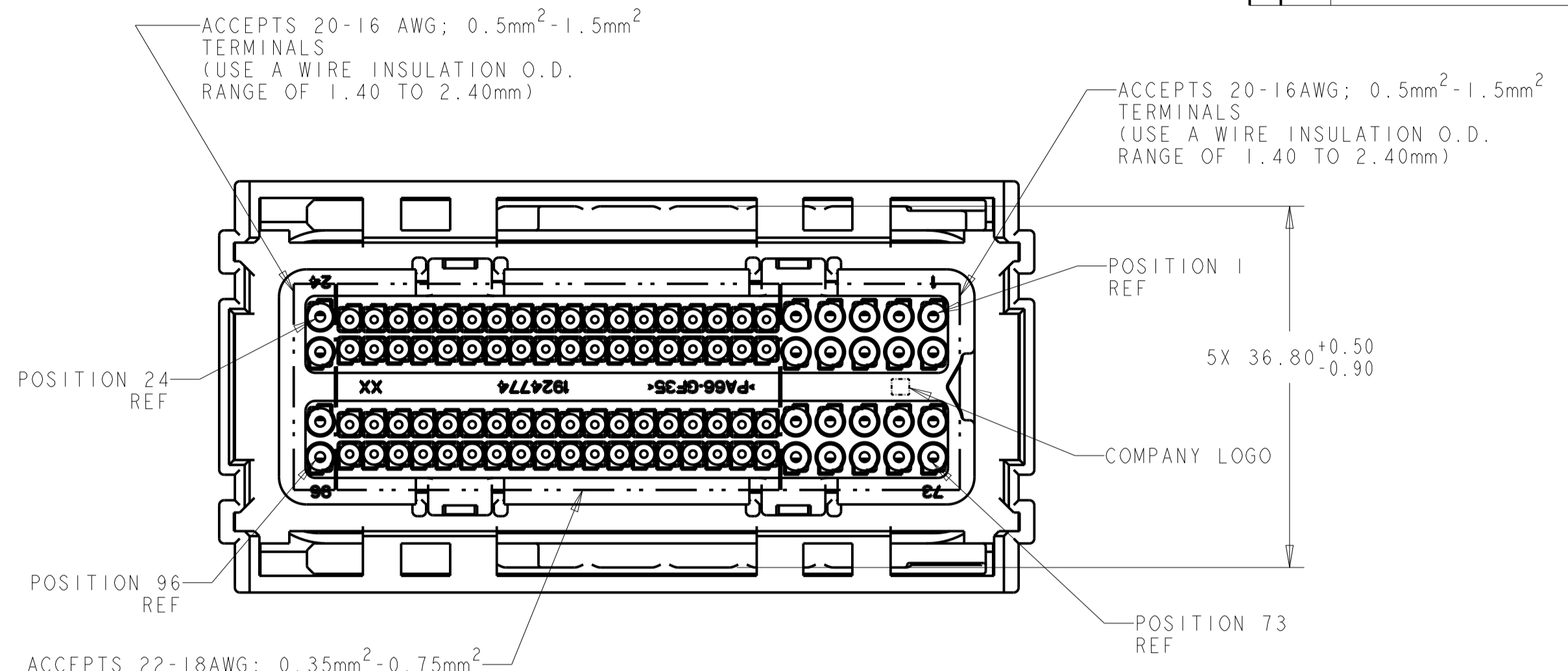

(METHOD FOR IDENTIFYING EXIT ORIENTATION)

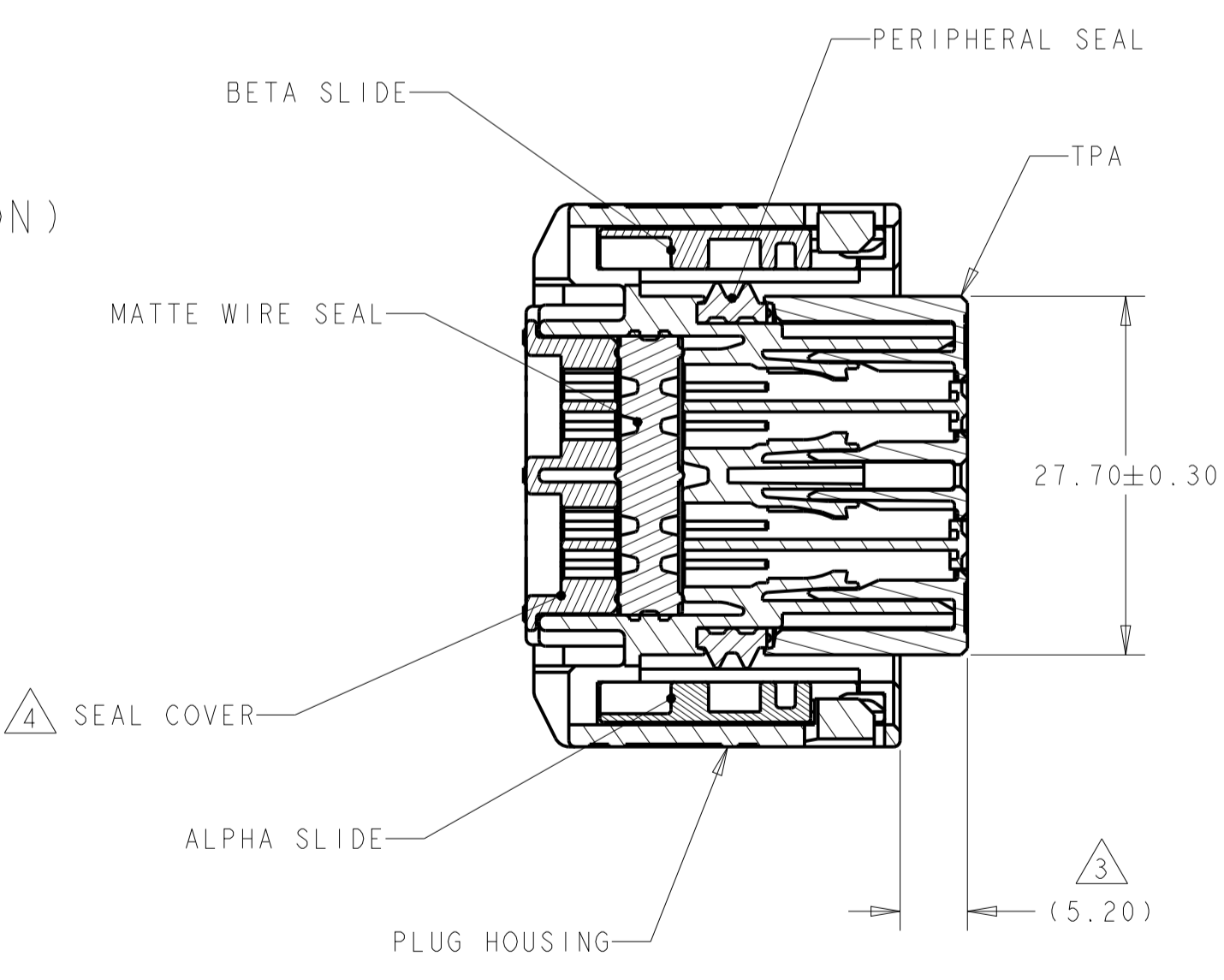

- 1. PLUG HOUSING AND SEAL COVER: NYLON 6/6, BLACK.
 TPA: NYLON 6/6, COLOR - SEE TABLE.
 MATTE WIRE SEAL: SILICONE, LIGHT BLUE.
 PERIPHERAL SEAL: SILICONE, GREEN.
 ALPHA SLIDE: NYLON 6/6, BLUE.
 BETA SLIDE: NYLON 6/6, GREEN.
- 2. TPA SHOWN IN PRE-LATCHED, AS SHIPPED, POSITION.
- 3. TPA SHOWN IN CLOSED POSITION.
- 4. SEE TABLE ON SHEET 2 FOR SEAL COVER PIN OUT CONFIGURATION.
- 5. PLUG ASSEMBLY MATES WITH TE CONNECTIVITY INTERFACE DRAWING 1924771_INT, POLARIZATION A.
- 6. PLUG ASSEMBLY WILL ACCEPT THE FOLLOWING GET TERMINAL PART NUMBERS:
 - 1393364-1 (GOLD 22AWG; 0.35mm²)
 - 1393365-1 (GOLD 18-20AWG; 0.75mm²-0.5mm²)
 - 1924878-1 (TIN/SILVER 22AWG; 0.35mm²)
 - 1924879-1 (TIN/SILVER 18-20AWG; 0.75mm²-0.5mm²)
 - 1924782-1 (TIN/SILVER 1.0mm²)
 - 1924880-1 (TIN/SILVER 16AWG; 1.5mm²)

- 7. WIRE DRESS ASSEMBLY MUST BE INSTALLED ONTO PLUG ASSEMBLY WITH LEVER IN LOCKED POSITION.
- 8. APPLICATION SPEC'S: 408-10229, 408-10230
- 9. NOTE DELETED.
- 10. FORCE TO SEAT TPA COMPONENT FROM PRE-SET TO LOCKED (FULLY LOADED W/ TERMINALS) TO BE 83N MAX.
- 11. FORCE TO MOVE TPA FROM FULLY LOCKED TO PRE-SET TO BE 115N MAX. FLAT BLADE SCREWDRIVER SUGGESTED FOR REMOVAL OF TPA.

ALL CLOSED	GRAY	A	9-1924940-9
SEE TABLE, SH 2	GRAY	A	2-1924940-6
SEE TABLE, SH 2	GRAY	A	2-1924940-5
SEE TABLE, SH 2	GRAY	A	2-1924940-4
SEE TABLE, SH 2	GRAY	A	2-1924940-3
SEE TABLE, SH 2	GRAY	A	2-1924940-2
SEE TABLE, SH 2	GRAY	A	2-1924940-1
SEE TABLE, SH 2	GRAY	A	2-1924940-0
SEE TABLE, SH 2	GRAY	A	1-1924940-9
SEE TABLE, SH 2	GRAY	A	1-1924940-8
SEE TABLE, SH 2	GRAY	A	1-1924940-7
SEE TABLE, SH 2	GRAY	A	1-1924940-6
SEE TABLE, SH 2	GRAY	A	1-1924940-5
SEE TABLE, SH 2	GRAY	A	1-1924940-4
SEE TABLE, SH 2	GRAY	A	1-1924940-3
SEE TABLE, SH 2	GRAY	A	1-1924940-2
SEE TABLE, SH 2	GRAY	A	1-1924940-1
SEE TABLE, SH 2	GRAY	A	1-1924940-0
SEE TABLE, SH 2	GRAY	A	1924940-9
SEE TABLE, SH 2	GRAY	A	1924940-8
SEE TABLE, SH 2	GRAY	A	1924940-7
SEE TABLE, SH 2	GRAY	A	1924940-6
SEE TABLE, SH 2	GRAY	A	1924940-5
SEE TABLE, SH 2	GRAY	A	1924940-4
SEE TABLE, SH 2	GRAY	A	1924940-3
SEE TABLE, SH 2	GRAY	A	1924940-2
SEE TABLE, SH 2	GRAY	A	1924940-1
SEE TABLE, SH 2	GRAY	A	1924940-0
ALL OPEN	GRAY	A	1924940-1
BLOCKED CIRCUITS	TPA COLOR	INDEX REF	PART NUMBER

THIS DRAWING IS A CONTROLLED DOCUMENT.

OWN: D. J. HARDY 29NOV2007
 CHK: A. J. VASBINDER 03DEC2007
 APVD: A. J. VASBINDER 03DEC2007

DIMENSIONS: mm

TOLERANCES UNLESS OTHERWISE SPECIFIED:

0 PLC	±
1 PLC	±0.25
2 PLC	±
3 PLC	±
4 PLC	±

MATERIAL: FINISH:

WEIGHT:

CUSTOMER DRAWING

TE Connectivity

NAME: PLUG ASSEMBLY, 96 POSITION, INDEX A - LEFT EXIT, SEALED, SPEC 11

SIZE: A100779 C=1924940

SCALE: 2:1 SHEET 1 OF 2 REV: C5

