

ATE4/ATLE4

Washable

Subminiature Toggle Switch With Locking Lever

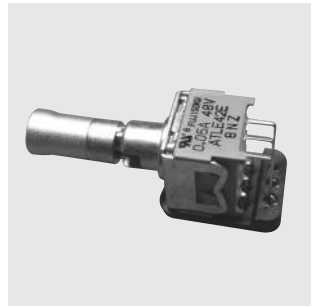

UL

RoHS Compliant

Features

1. Twin-contact clip mechanism for high reliability.
2. Process sealed structure

Specifications

Rating	Max.	50mA 60VAC/DC
	Min.	1 μ A 20mVAC/DC
	UL	48VAC/DC 50mA
Initial contact resistance	100m Ω max. (1.5mA 200 μ VAC)	
Dielectric strength	500VAC 1 minute	
Insulation resistance	500M Ω min. (500VDC)	
Electrical life	10,000 cycles at max. rating	
Operating temperature range	-20°C ~ +85°C	
Storage temperature range	-40°C ~ +85°C	

Part Numbering

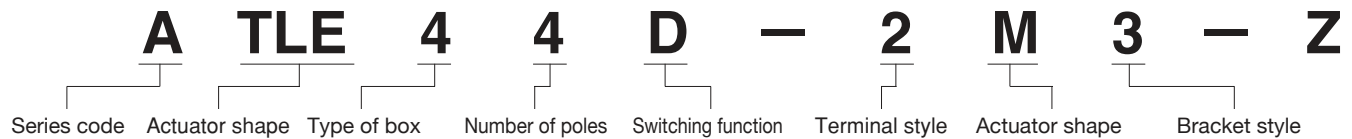

Code	Type
TE	Standard type
TLE	Locking lever type

Fig.	Type of box
4	Type of box
None	Low profile

Fig.	Number of poles
2	2 poles
4	4 poles

Code	Switching function
D	ON - ON
E	ON - OFF - ON
N	ON - ON

Fig.	Terminal style
2	PC Straight
5	Right angle (0.2 inch pitch)
6	Right angle (0.3 inch pitch)

Code	Actuator shape
M	Standard

Fig.	Bracket
3	Without bracket
4	With bracket

PC Hole Layouts

Type	Terminal style	PC Straight (Without bracket)
ATE42□-2M3-Z	2-poles	
ATE44□-2M3-Z	4-poles	

Type	Terminal style	PC Straight (With bracket)
ATE42□-2M3-Z	2-poles	
ATE44□-2M4-Z	4-poles	

■ PC Hole Layouts

Type	Terminal style	Right angle
ATE42□-6M3-Z	2-poles	
ATE44□-6M3-Z ATLE44□-6M3-Z	4-poles	

■ Packaging Specification

<p>Plastick Pack</p>	<p>Standard type 50 pcs/pack</p>
<p>ATE-2M</p> <p>Plastick Pack</p>	<p>Right-angle type 50 pcs/pack</p>
<p>ATE-6M ATLE-2M ATLE-5M ATLE-6M</p>	

■ Type of Actuator

Standard type	Locking lever type

ATE (Subminiature Toggle Switch)

4PDT

PC Straight

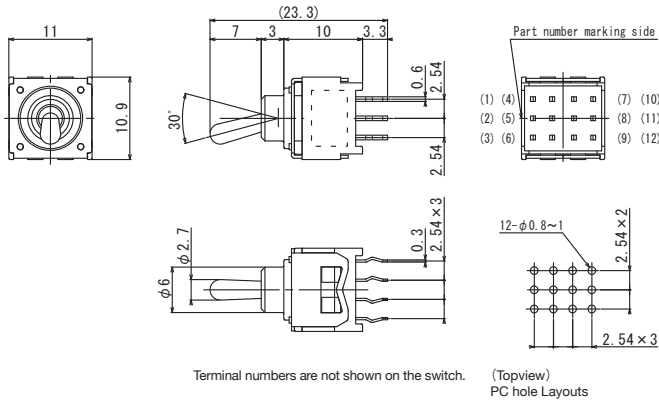

Switching function	Viewed from part No. marking side		
Part No.			
☆ ATE44E-2M3-Z	ON	OFF	ON
Connecting terminals	2-1 5-4 8-7 11-10	-	2-3 5-6 8-9 11-12

ATE (Subminiature Toggle Switch)

4PDT

PC Straight

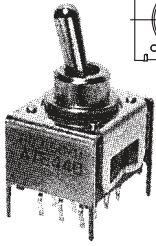

With bracket

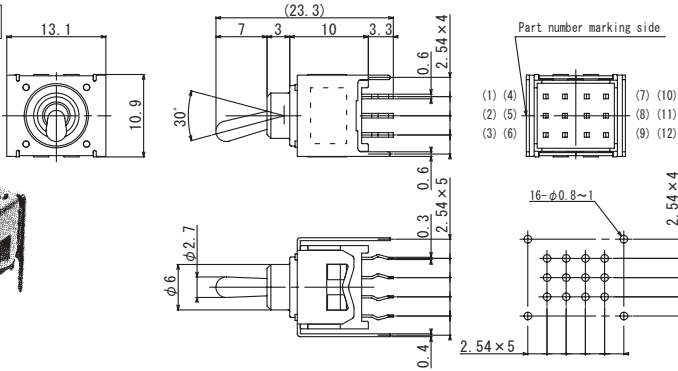

Terminal numbers are not shown on the switch. (Topview) PC hole Layouts

Switching function	Viewed from part No. marking side		
Part No.			
★ATE44D-2M4-Z	ON	—	ON
Connecting terminals	2-1		2-3
	5-4		5-6
	8-7	—	8-9
	11-10		11-12

DPDT

(Mounting height : 7mm)

Right angle (0.3 inch pitch)

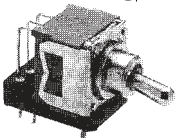

Terminal numbers are not shown on the switch.

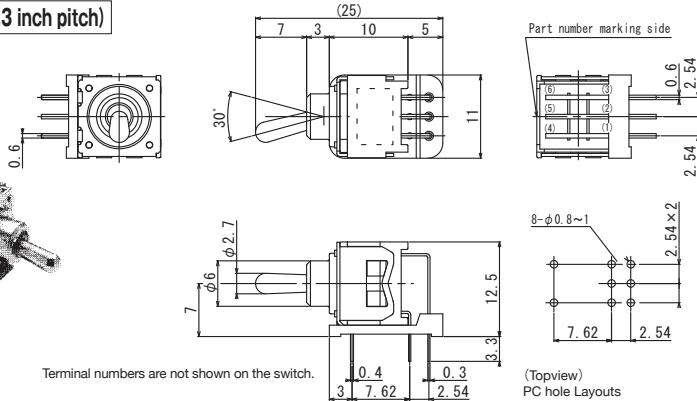

(Topview) PC hole Layouts

Switching function	Viewed from part No. marking side		
Part No.			
★ATE42D-6M3-Z	ON	—	ON
Connecting terminals	2-3		2-1
	5-6		5-4

4PDT

(Mounting height : 7mm)

Right angle (0.3 inch pitch)

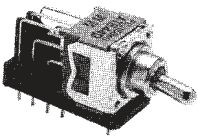

Terminal numbers are not shown on the switch.

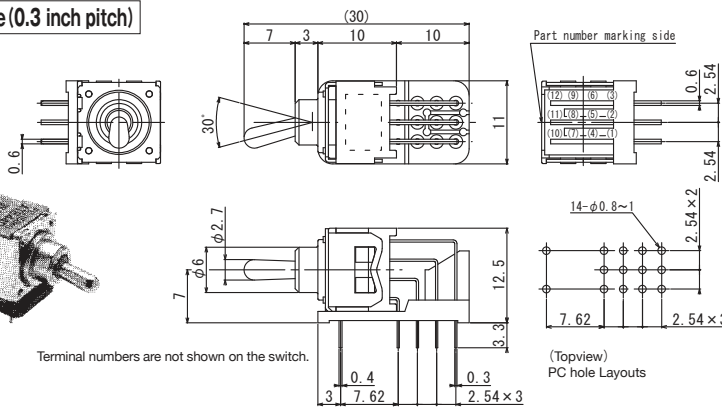

(Topview) PC hole Layouts

Switching function	Viewed from part No. marking side		
Part No.			
★ATE44D-6M3-Z	ON	—	ON
Connecting terminals	2-3		2-1
	5-6		5-4
	8-9	—	8-7
	11-12		11-10

ATLE (Locking Lever Toggle Switch)

DPDT PC Straight

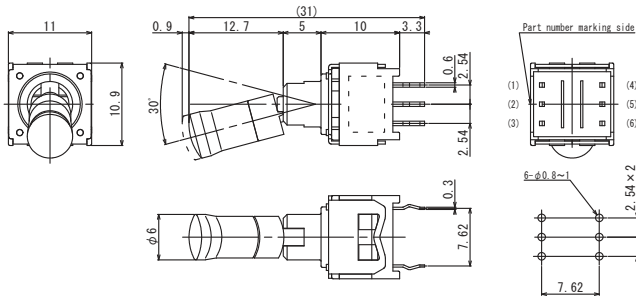
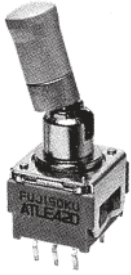

(Topview)
PC hole Layouts

Terminal numbers are not shown on the switch.

Switching function	Viewed from part No. marking side		
Part No.			
★ATLE42D-2M3-Z	ON	—	ON
Connecting terminals	2-1 5-4	—	2-3 5-6

DPDT PC Straight



With bracket

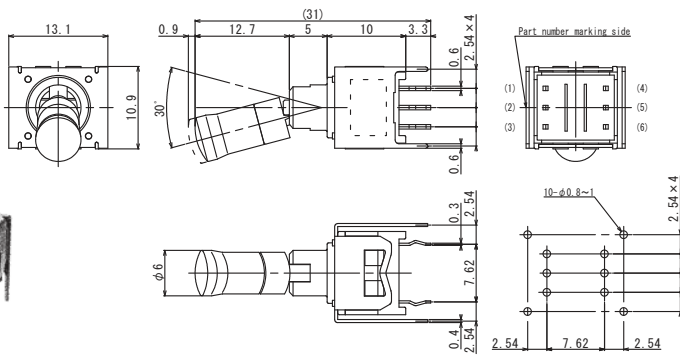

(Topview)
PC hole Layouts

Terminal numbers are not shown on the switch.

Switching function	Viewed from part No. marking side		
Part No.			
☆ATLE42D-2M4-Z	ON	—	ON
☆ATLE42E-2M4-Z	ON	OFF	ON
Connecting terminals	2-1 5-4	—	2-3 5-6

ATLE (Locking Lever Toggle Switch)

DPDT

(Mounting height : 4.4mm)

ATLE2N-5M3-Z

Low profile

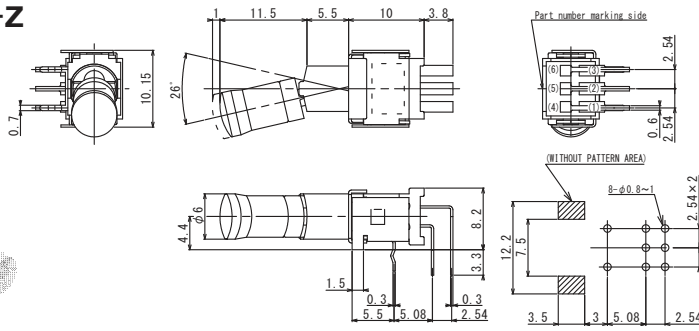
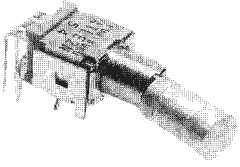

Switching function	Viewed from part No. marking side	
Part No.	ON	ON
★ATLE2N-5M3-Z	ON	ON
Connecting terminals	2-3 5-6	2-1 5-4

Right angle (0.2 inch pitch)

Terminal numbers are not shown on the switch.

(Topview)
PC hole Layouts

4PDT

(Mounting height : 7mm)

Right angle (0.3 inch pitch)

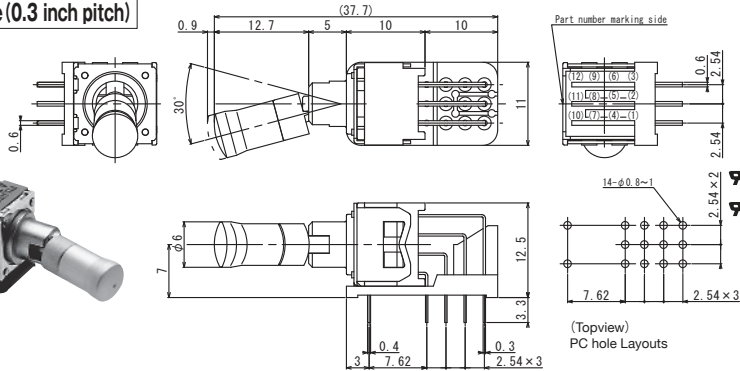
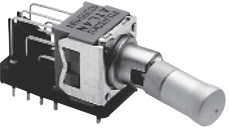

Switching function	Viewed from part No. marking side		
Part No.	ON	—	ON
★ATLE44D-6M3-Z	ON	—	ON
★ATLE44E-6M3-Z	ON	OFF	ON
Connecting terminals	2-3 5-6 8-9 11-12	—	2-1 5-4 8-7 11-10

Terminal numbers are not shown on the switch.

(Topview)
PC hole Layouts

■ Standard Accessories

For Locking Lever Type

《Supplied separately》

Color Cap		
Dimensions	Color	Part No.
	Silver	140000470225
	Red	140000470234

A Silver cap is attached to the switch. Red, Blue, and Black caps are also available (sold separately).

■ Flux Cleaning

- (1) Solvent : Fluorine or Alcohol type.
- (2) Cleaning after soldering should be done after the terminal temperature falls to 90°C or below, or after leaving the switch for five minutes or longer at room temperature.

■ Soldering Specifications

- (1) Manual Soldering
 - Device : Soldering iron
 - 380°C, Max.; 3 seconds, Max.
 - (2) Auto Soldering
 - Device : Jet wave type or dip type
 - 275°C, Max.; 6 seconds, Max.
- Pre-heating should be done at temperatures ranging from 80°C to 120°C and within 120 sec.

■ Mounting of Switch

- Do not bend the terminals before mounting the switch on the PC board.
- After mounting the switch, do not place the device in such a way that the device weight will be applied on to the actuator of the switch.
- Do not apply load exceeding 12.74 N to the knob.