

LOC		REV		REVISIONS		
NO	DATE	BY	CHK	DESCRIPTION	DATE	BY
AA	22					
E1				REVISED PER ECO-11-005140	25MAR11	RK
F				ECO-11-015766	30MAY2011	EL

MECHANICAL:

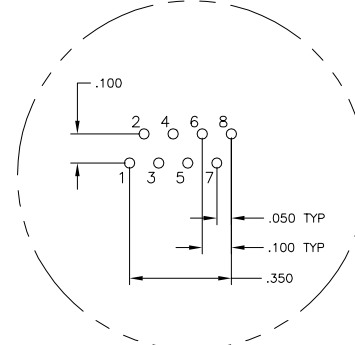

Pin Designations

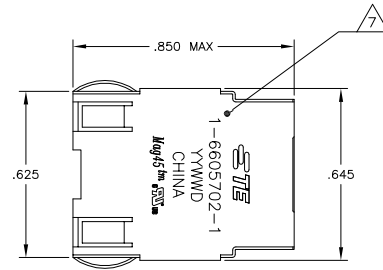
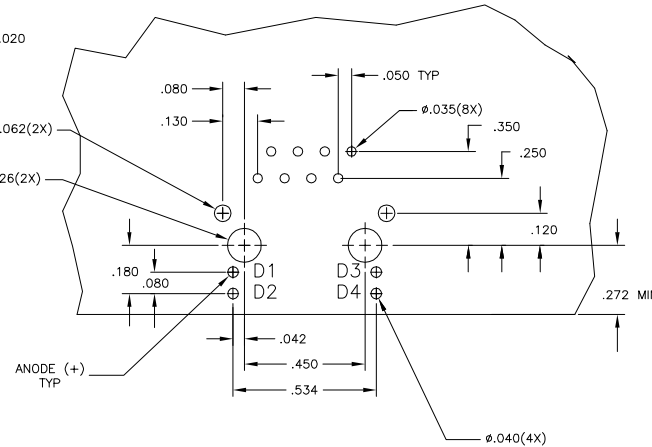
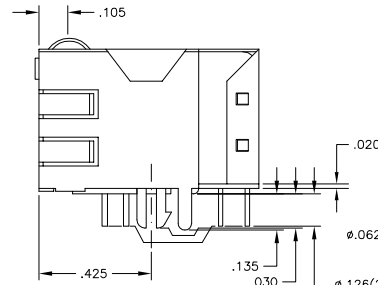
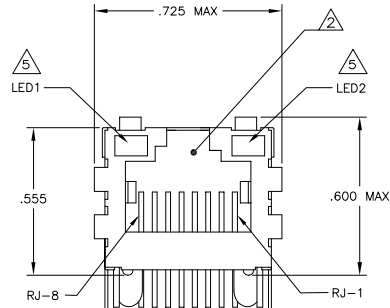

**Suggested PCB Layout
(Component Side)**

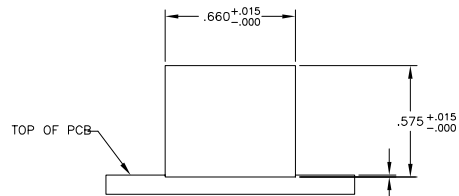

Suggested Panel Cutout

706 10/100 BASE-T CIRCUIT

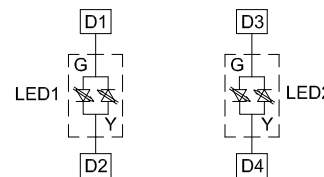
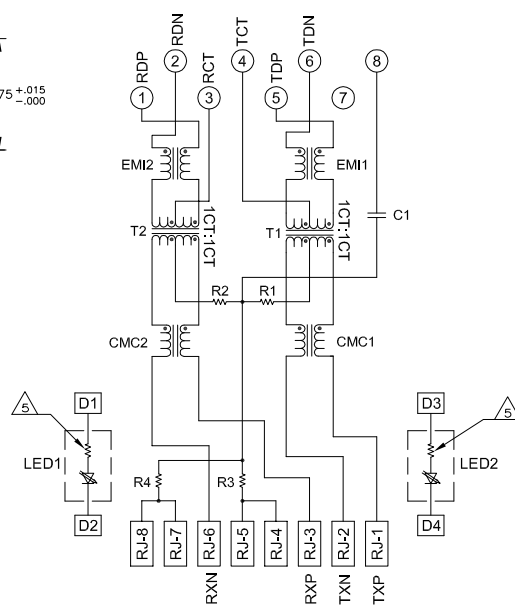

**LED CONFIGURATION
FOR BI-COLOR**

C1=1000pF, 2kV CAPACITOR
R1-R4 = 75 OHMS, 1/16 W RESISTORS

MATERIALS:
HOUSING - THERMOPLASTIC PET POLYESTER FLAMMABILITY RATING UL 94V-0. SHIELD - .010" THICK, C26800 BRASS PREPLATED WITH 30μinch SEMI-BRIGHT NICKEL; SOLDER TABS POST-DIPPED WITH 100μinch MIN SAC SOLDER.
MOD JACK CONTACTS - .0157" x .018" THICK, PHOSPHOR BRONZE, 50μinch MIN OVERALL NICKEL UNDERPLATE, WITH SELECT 50μinch MIN HARD GOLD FINISH PLATE. SOLDER TAILS WITH 100μinch MIN MATTE TIN AND/OR SAC SOLDER DIP. LIGHT EMITTING DIODE(LED) - DIFFUSED EPOXY LENS, .020" x .020" CARBON STEEL WIREFRAME LEADS PREPLATED WITH 80μinch SILVER OVER 40μinch NICKEL UNDERPLATE OVER 40μinch COPPER UNDERPLATE; POST-PLATED WITH 100μinch MIN MATTE TIN AND/OR SAC SOLDER DIP OR PURE TIN SOLDER DIP.

RJ45 JACK CAVITY CONFORMS TO FCC RULES AND REGULATIONS PART 68, SUB PART F.

MAGNETICS:
-APPLICATION: 10/100 BASE-T
-IMPEDANCE: 100 OHMS
-TURNS RATIO (CHIP CABLE): TX = 1:1, RX = 1:1
-OPEN CIRCUIT INDUCTANCE (OCL): 350uH MIN @100kHz, 0.1VRMS, 8mADC BIAS FROM 0°C TO 70°C, TX AND RX
-PERFORMANCE @ 25°C
INSERTION LOSS (IL): 11dB MAX FROM 0.5MHz TO 100MHz
RETURN LOSS (RL): 18dB MIN FROM 0.5MHz TO 30MHz
18-20LOG(f/30)dB MIN FROM 30.1MHz TO 60MHz
12dB MIN FROM 60.1MHz TO 80MHz
CROSSTALK ATTENUATION: 35dB MIN FROM 0.5MHz TO 40MHz
33-20LOG(f/50)dB MIN FROM 40.1MHz TO 100MHz
COMMON MODE REJECTION RATIO (CMRR): 30dB MIN FROM 0.5MHz TO 100MHz
ISOLATION VOLTAGE: 2250VDC (MAX) FOR 60 SECONDS WITH A RISE TIME OF 500V/SEC.

4. OPERATING TEMPERATURE: FROM 0°C - +70°C.

THE 250 OHM LED RESISTORS ARE OPTIONAL, PLEASE SEE CHART FOR PRESENCE OR ABSENCE OF LED RESISTORS. IF THE LED WITHOUT 250 OHM RESISTORS, LED IS DRIVEN WITH CONSTANT CURRENT AT APPROX 20mA.
LED COLOR: DOMINANT WAVELENGTH (AD): GREEN 568 nm TYP @ IF=20mA FORWARD VOLTAGE (VF): GREEN 2.2V TYP @ IF=20mA
DOMINANT WAVELENGTH (AD): YELLOW 588 nm TYP @ IF=20mA FORWARD VOLTAGE (VF): YELLOW 2.1V TYP @ IF=20mA
IF THE LED WITH 250 OHM RESISTORS, LED IS DRIVEN WITH 5V VOLTAGE AND THE MAX OPERATING CURRENT IS 20mA
LED COLOR : DOMINANT WAVELENGTH (AD): GREEN 568 nm TYP @ VF=5V FORWARD CURRENT (IF): GREEN 12 mA TYP @ VF=5V
DOMINANT WAVELENGTH (AD): YELLOW 588 nm TYP @ VF=5V FORWARD CURRENT (IF): YELLOW 13 mA TYP @ VF=5V

INDICATED CONNECTIONS ARE FOR NIC CONFIGURATION. THE MAGNETICS ARE SYMMETRICAL, AND THEREFORE DOES SUPPORT AUTO-MDI/MDIX.

TE CONNECTIVITY LOGO, TE CONNECTIVITY PART NUMBER, DATE CODE, COUNTRY OF ORIGIN AND AGENCY APPROVAL MARKING IN APPROXIMATE LOCATION SHOWN.

THESE PARTS ARE RECOMMENDED FOR WAVE SOLDERING PROCESS, PREHEAT TEMPERATURE IS 120°C TO 160°C, 120 SECONDS TO 180 SECONDS, PEAK SOLDERING TEMPERATURE IS 260 °C MAX, 10 SECONDS MAX.

DIMENSION	A	YES	GREEN	YES	GREEN	YES	6-6605702-1
.145±.010	YES	GREEN	NO	GREEN	NO	5-6605702-7	
.145±.010	YES	GREEN/YELLOW	NO	GREEN/YELLOW	NO	5-6605702-6	
.145±.010	YES	GREEN	YES	YELLOW	YES	5-6605702-1	
.100±.010	YES	GREEN/YELLOW	NO	GREEN/YELLOW	NO	2-6605702-6	
.145±.010	NO	GREEN	YES	GREEN	YES	1-6605702-1	

DIMENSIONS:		DRAWING NO:		REV:		DATE:	
INCHES	MILLIMETERS	100779	000000	0	0	000000	000000
MATERIAL:		FINISH:		WEIGHT:		SCALE:	
TE CONNECTIVITY		TE CONNECTIVITY		TE CONNECTIVITY		TE CONNECTIVITY	