

THIS INFORMATION IS CONFIDENTIAL AND PROPRIETARY TO CW INDUSTRIES INCORPORATED AND ITS AFFILIATES. IT MAY NOT BE DISCLOSED TO ANYONE, OTHER THAN CW INDUSTRIES PERSONNEL, WITHOUT WRITTEN AUTHORIZATION FROM CW INDUSTRIES INCORPORATED, SOUTHAMPTON, PENNSYLVANIA USA.

Rating	21A 14VDC	
Contact Resistance	50m ohm Max.	
Insulation Resistance	DC 500V 100M ohm Min.	
Dielectric Strength	AC 1500V 1 minute	
Operation Temperature	- 25 ° ~ + 85 °	
Switch Function	5P SPST OFF - (ON)	
Lamp Type	12VDC 14V w/resistor	LED 1 Independent LED 2 Dependent

() = Momentary Function

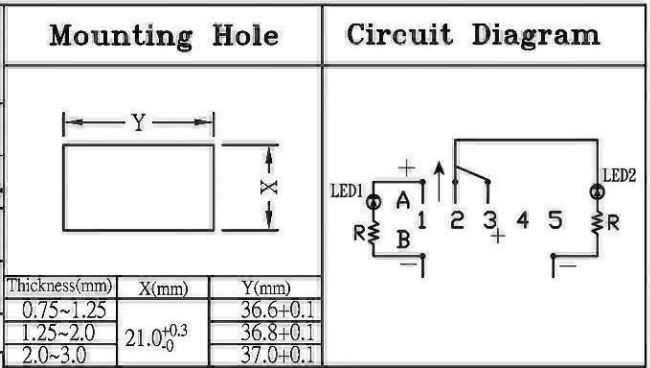

Material:

1. Frame: Nylon-66(94V-2) - Black
Actuator: Nylon-66+33%GF - Black
Lens 1: PC, Amber
Lens 2: PC, Green
Terminal: Silver plated copper
(excepted lamp terminal)
Printed: None
2. Waterproof: "IP-67".

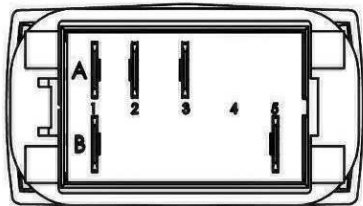
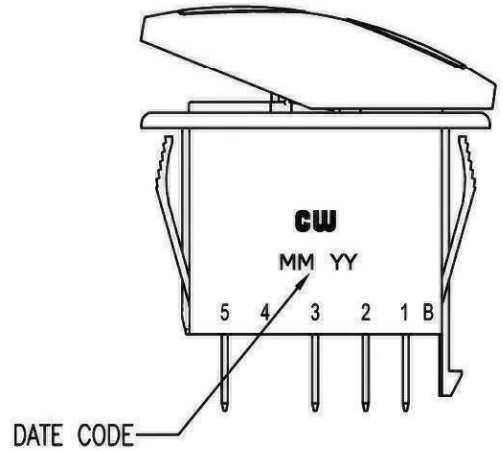
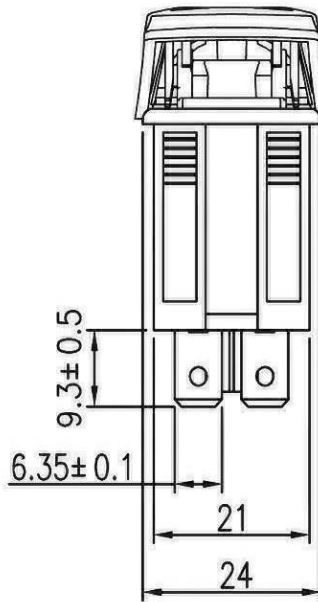
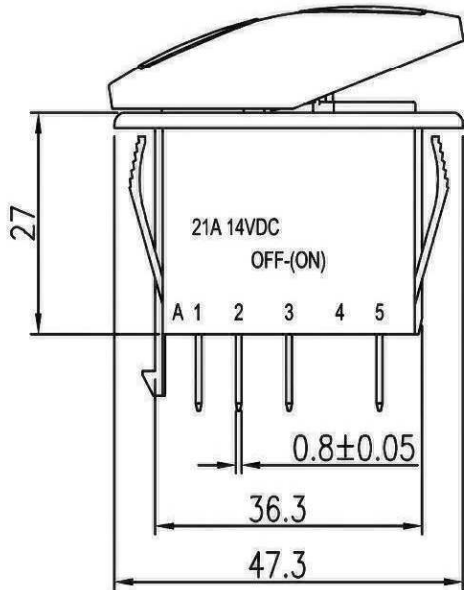
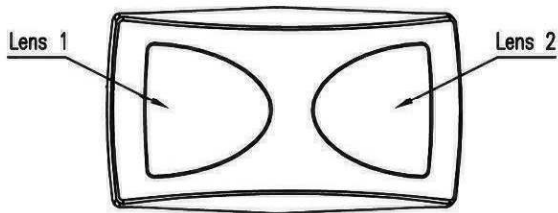

TOLERANCE: ±0.3mm UNLESS OTHERWISE SPECIFIED.

RoHS Compliant

3	Added Lamp Type. 12/16/2011.
2	Changed IP-66 to IP-67. 12/13/10
1	Reversed Button & Function direction. 8/24/10.

CW INDUSTRIES
Southampton, Pa. 18966
Tel 215.355.7080/www.cwind.com

Date Drawn: 5/20/10

Rev. 3

Unit: mm

Checked By: *G. Gold*

Title: **ROCKER SWITCH**

CW P/N: **GRB292N301BBAG1**