

80 Amp Schottky Rectifier

SBR8040 — SBR8050

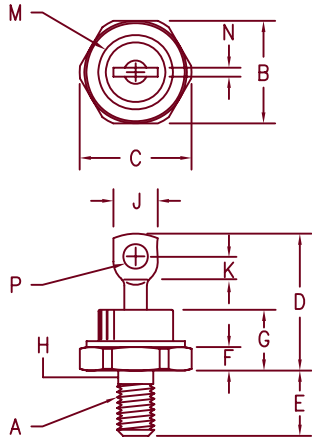

Notes:

1. Full threads within 2 1/2 threads
2. Standard Polarity: Stud is Cathode
Reverse Polarity: Stud is Anode

Dim.	Inches		Millimeter		Notes
	Minimum	Maximum	Minimum	Maximum	
A	----	----	----	----	1/4-28
B	.669	.688	17.00	17.47	
C	----	.794	----	20.16	
D	.750	1.00	19.05	25.40	
E	.422	.453	10.72	11.50	
F	.115	.200	2.93	5.08	
G	----	.450	----	11.43	
H	.220	.249	5.59	6.32	1
J	----	.375	----	9.52	
K	.156	----	3.97	----	
M	----	.510	----	12.95	Dia
N	----	.080	----	2.03	
P	.140	.175	3.56	4.44	Dia

DO-203AB (DO-5)

Microsemi Catalog Number	Industry Part Number	Working Peak Reverse Voltage	Repetitive Peak Reverse Voltage
SBR8040 *	75HQ035, 85HQ035 75HQ040, 85HQ040 MBR8040	40V	40V
SBR8045 *	75HQ045, 85HQ045 MBR8045	45V	45V
SBR8050 *		50V	50V

*Add Suffix R For Reverse Polarity

- Schottky Barrier Rectifier
- 175°C Junction Temperature
- Guard Ring Protection
- Reverse Energy Tested
- VRRM - 40 to 50 Volts
- 80 Amperes

Electrical Characteristics

Average forward current,	I _{F(AV)} = 80 Amps	T _C = 130°C, Square wave, R _{θJC} = 0.8°C/W
Maximum surge current,	I _{FSM} = 1200 Amps	8.3 ms, half sine T _J = 175°C
Max repetitive peak reverse current	I _{R(OV)} = 2 Amps	f = 1 KHz, 25°C, 1 μsec Square wave
Max peak forward voltage,	V _{FM} = 0.58 Volts	I _{FM} = 80A, T _J = 175°C*
Max peak forward voltage,	V _{FM} = 0.74 Volts	I _{FM} = 80A, T _J = 25°C*
Max peak reverse current	I _{RM} = 30 mA	V _{RRM} , T _J = 125°C*
Max peak reverse current	I _{RM} = 2 mA	V _{RRM} , T _J = 25°C
Typical junction capacitance	C _J = 2300 pF	V _R = 5.0V, T _J = 25°C

*Pulse test: Pulse width 300 μsec, Duty cycle 2%

Thermal and Mechanical Characteristics

Storage temp range	T _{STG}	-65°C to +175°C
Operating junction temp range	T _J	-65°C to +175°C
Max thermal resistance	R _{θJC}	0.8°C/W Junction to sink
Typical thermal resistance (greased)	R _{θCS}	0.5°C/W Case to sink
Mounting torque		25-30 inch pounds
Weight		.54 ounce (15.3 grams) typical



6 Lake Street
Lawrence, MA 01841
PH: (978) 620-2600
FAX: (978) 689-0803
www.microsemi.com

05-30-07 Rev. 3

SBR8040 — SBR8050

Figure 1
Typical Forward Characteristics

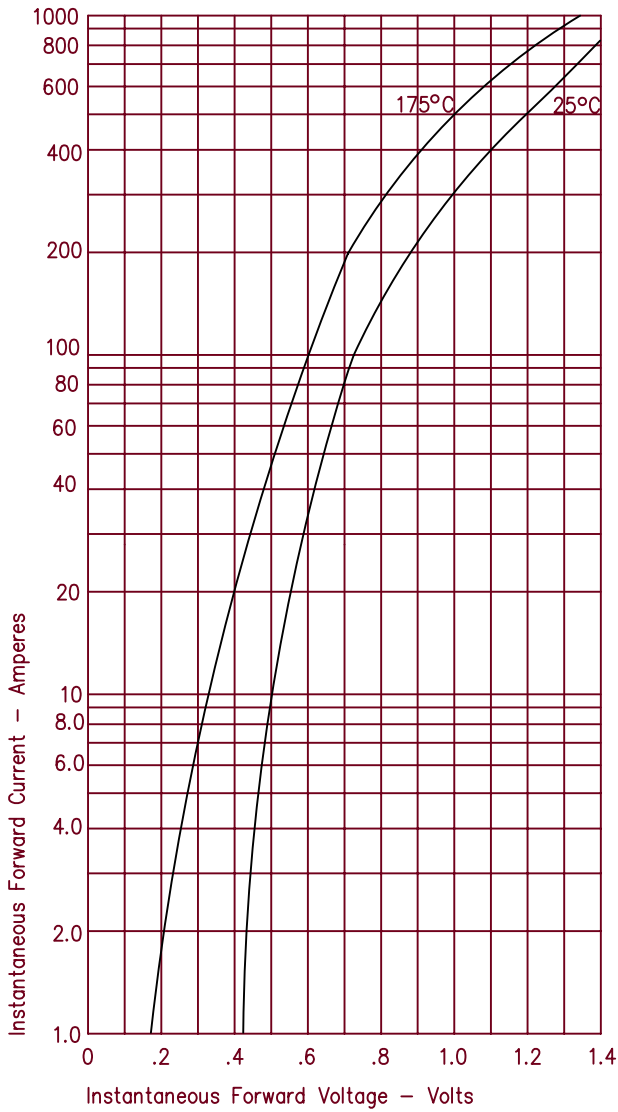

Figure 3
Typical Junction Capacitance

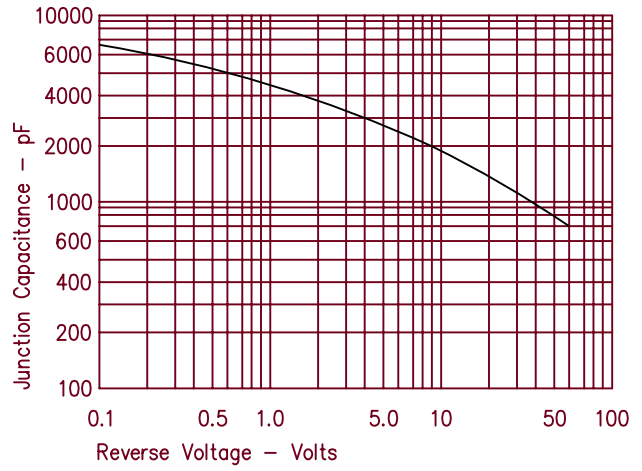

Figure 4
Forward Current Derating

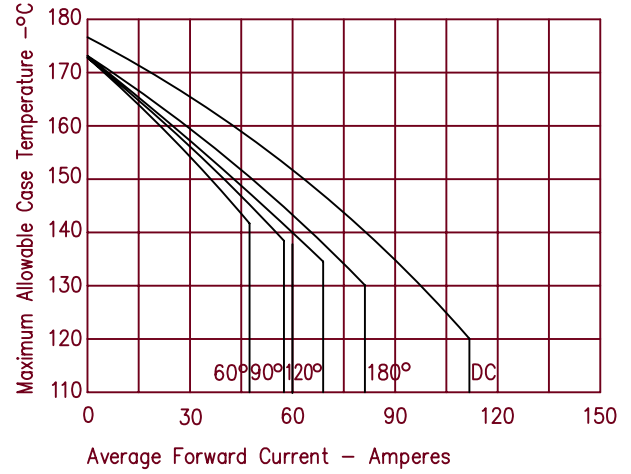

Figure 2
Typical Reverse Characteristics

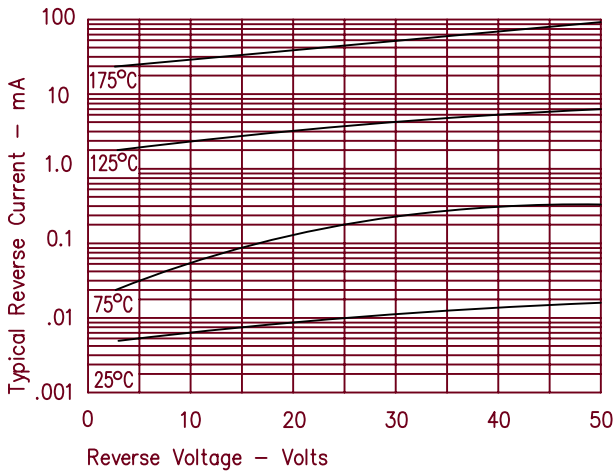

Figure 5
Maximum Forward Power Dissipation

