

REV.	DESCRIPTION	DATE	APPROVED
C	Engineering Update w/o Changes	02/26/04	M. C.
D	Remove Material Code	05/28/16	J. C.

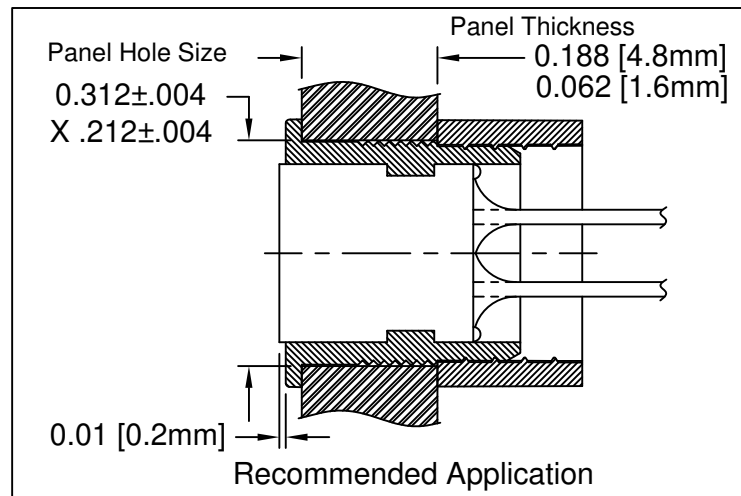
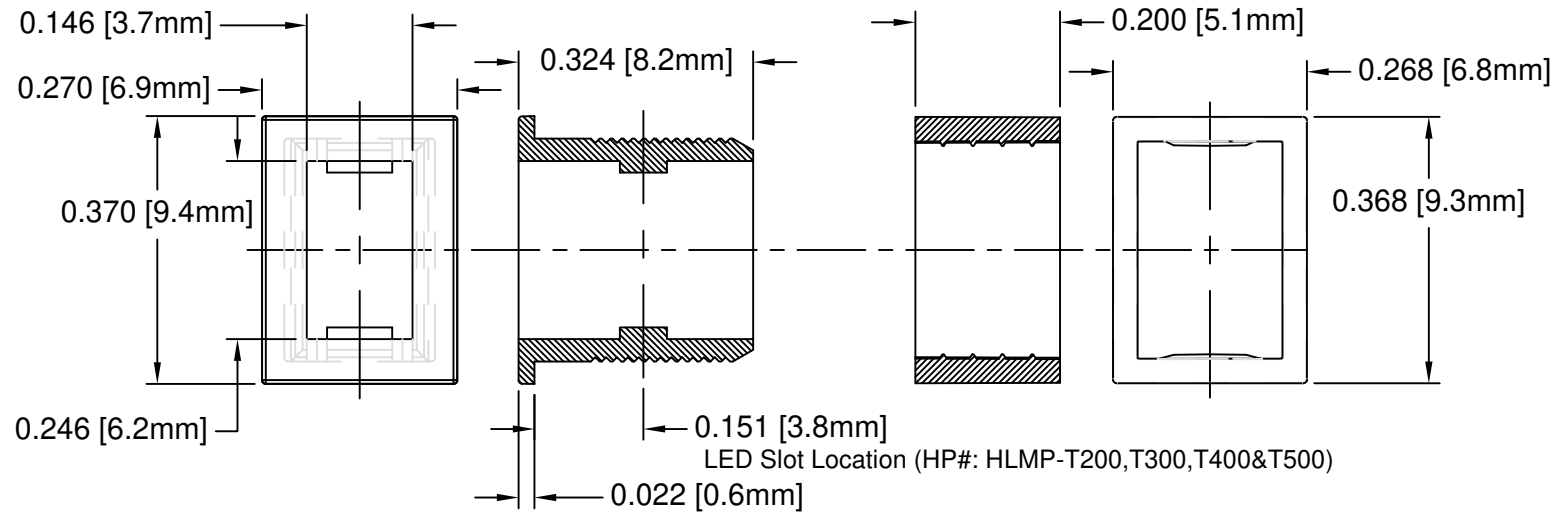

2. MATERIAL: NYLON 6/6, 94V-2, BLACK.

1. GENERAL SPECIFICATIONS: BIVAR MOLDED COMPONENT SPECIFICATION BV00-E101.

STANDARD TOLERANCE (UNLESS OTHERWISE SPECIFIED)		BIVAR®	
DECIMALS	ANGULAR	4 THOMAS, IRVINE, CA. 92618	
.X ± .1	X° ± 1°	TEL: (949) 951-8808 FAX: (949) 951-3974	
.XX ± .01		TITLE: CLIP & RING SET FOR RECTANGULAR LED	
.XXX ± .005		PART NO: CR-300	REVISION: D
DESIGNED: D. Green	DATE: 11/13/02	CAGE CODE : 32559 SHEET # 1 OF 1	
CHECKED: M. Chen	DATE: 11/13/02	CAD GENERATED DOCUMENT. DO NOT MEASURE DRAWING.	