

REV.	DATE	DESCRIPTION
A	11/08/01	MODIFY MATING FACE / ADD SCTE NOTE
B	12/22/05	MODIFY SOLDER BARREL PLATING / UPDATE DRAWING FORMAT
C	11/18/07	ADD NOTES, REVISE CONTACT PIN DIAMETER 2.3mm

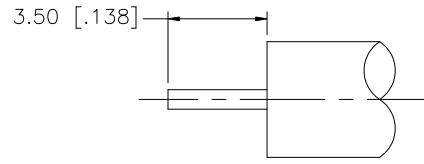

RECOMMENDED CABLE STRIPPING DIM'S.

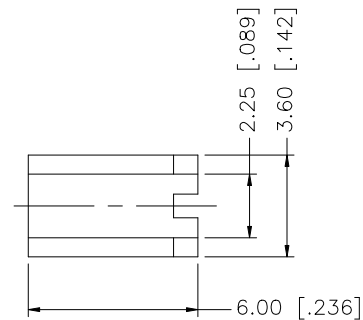
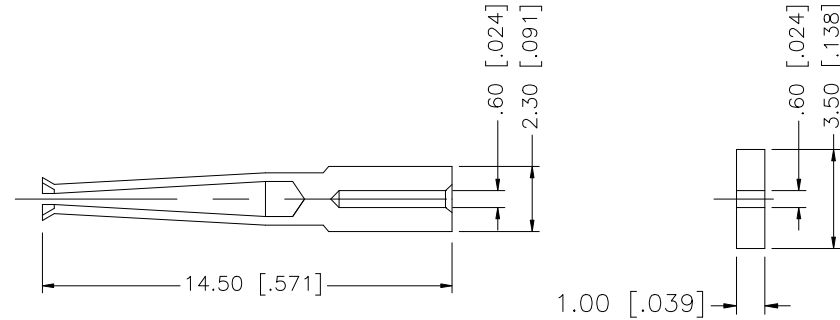
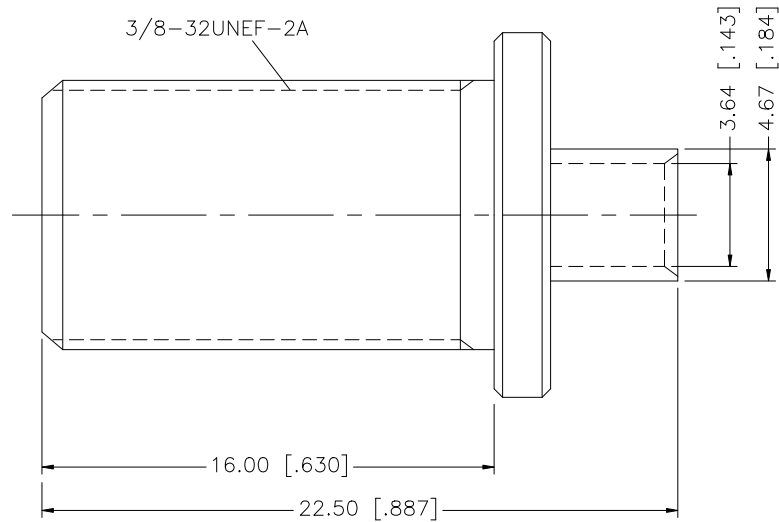

NOTES:

1. IMPEDANCE: 75ohm
2. TEMPERATURE RANGE: -40°F TO 140°F
3. FREQUENCY RANGE: DC TO 2 GHz
4. RETURN LOSS: LESS THAN -20dB AT 2 GHz
5. INSERTION LOSS LESS THAN .05dB AT 2 GHz
6. RF LEAKAGE: -100dB AT 1 GHz
7. INSULATION RESISTANCE: 5000 MEGAohm (MIN)
8. DIELECTRIC WITHSTANDING VOLTAGE: 1000V RMS
9. MATING TORQUE: 20 in/lbs. RECOMMENDED
10. CONTACT PIN TO SOLDER
11. MAX. PANEL THICKNESS = 7.0mm
12. ACCEPTS $\varnothing 0.5 \sim \varnothing 1.05$ CENTER CONDUCTOR TYPICAL.
13. MEETS SCTE INTERFACE DIMENSIONS.

8				
7				
6				
5				
4	SOLDER BARREL	BRASS	BRIGHT TIN	1
3	CONTACT PIN	BER. COPPER	GOLD	1
2	INSULATOR	TEFLON	NATURAL	1
1	BODY	BRASS	BRIGHT TIN	1
	DESCRIPTION	MATERIAL	FINISH	QTY

UNLESS OTHERWISE SPECIFIED DIMENSIONS ARE IN MILLIMETERS. DIMENSIONS IN [] ARE IN INCHES AND FOR CUSTOMER REFERENCE ONLY.

UNLESS OTHERWISE SPECIFIED TOLERANCES FOR MILLIMETERS ARE:
0.5 - 8mm ± 0.20mm
8 - 30mm ± 0.40mm
30 - 120mm ± 0.50mm

UNLESS OTHERWISE SPECIFIED TOLERANCES FOR INCHES ARE:
.020 - .315 = ± 0.007"
.315 - 1.180 = ± 0.015"
1.180 - 4.724 = ± 0.020"

DO NOT SCALE DRAWING

APPROVALS	DATE
DRAWN G.R.S.	11/18/07
CHECKED	
ISSUED	
SHEET 1 OF 1	
CAD FILE	C:/222/222168.DWG

<h1>Amphenol Connex</h1>			
PART DESCRIPTION			
F DIRECT SOLDER JACK (FOR .085", .086" CABLE)			
PART NO.			
222168			
DWG. NO.	222168.DWG	REV.	C
SIZE	A	SCALE	NA