

LH28F640SPHT-PTLZ8

Flash Memory
64Mbit (4Mbitx16)

(Model Number: LHF64PZ8)

Spec. Issue Date: July 21, 2004
Spec No: EL167117

SPEC No.	EL167117
ISSUE:	Jul. 21, 2004

To; _____

S P E C I F I C A T I O N S

Product Type 64 Mbit Flash Memory

L H 2 8 F 6 4 0 S P H T — P T L Z 8

Model No. (L H F 6 4 P Z 8)

If you have any objections, please contact us before issuing purchasing order.

* This specifications contains 39 pages including the cover and appendix.
Refer to LH28F640SP series Appendix (FUM03201).

CUSTOMERS ACCEPTANCE

DATE: _____

BY: _____

PRESENTED

BY: *M. Nawaki*
M. NAWAKI
Dept. General Manager

REVIEWED BY: PREPARED BY:

M. Suminaga *S. Kouchi*
Product Development Dept. II
System-Flash Division
Integrated Circuits Group
SHARP CORPORATION

- Handle this document carefully for it contains material protected by international copyright law. Any reproduction, full or in part, of this material is prohibited without the express written permission of the company.
- When using the products covered herein, please observe the conditions written herein and the precautions outlined in the following paragraphs. In no event shall the company be liable for any damages resulting from failure to strictly adhere to these conditions and precautions.
 - (1) The products covered herein are designed and manufactured for the following application areas. When using the products covered herein for the equipment listed in Paragraph (2), even for the following application areas, be sure to observe the precautions given in Paragraph (2). Never use the products for the equipment listed in Paragraph (3).
 - Office electronics
 - Instrumentation and measuring equipment
 - Machine tools
 - Audiovisual equipment
 - Home appliance
 - Communication equipment other than for trunk lines
 - (2) Those contemplating using the products covered herein for the following equipment which demands high reliability, should first contact a sales representative of the company and then accept responsibility for incorporating into the design fail-safe operation, redundancy, and other appropriate measures for ensuring reliability and safety of the equipment and the overall system.
 - Control and safety devices for airplanes, trains, automobiles, and other transportation equipment
 - Mainframe computers
 - Traffic control systems
 - Gas leak detectors and automatic cutoff devices
 - Rescue and security equipment
 - Other safety devices and safety equipment, etc.
 - (3) Do not use the products covered herein for the following equipment which demands extremely high performance in terms of functionality, reliability, or accuracy.
 - Aerospace equipment
 - Communications equipment for trunk lines
 - Control equipment for the nuclear power industry
 - Medical equipment related to life support, etc.
 - (4) Please direct all queries and comments regarding the interpretation of the above three Paragraphs to a sales representative of the company.
- Please direct all queries regarding the products covered herein to a sales representative of the company.

CONTENTS

PAGE	PAGE
56-Lead TSOP (Normal Bend) Pinout 3	1 Electrical Specifications 16
Pin Descriptions..... 4	1.1 Absolute Maximum Ratings..... 16
CE0, CE1, CE2 Truth Table 5	1.2 Operating Conditions 16
Memory Map 6	1.2.1 Capacitance..... 17
Identifier Codes Address 7	1.2.2 AC Input/Output Test Conditions..... 17
OTP Block Address Map..... 8	1.2.3 DC Characteristics..... 18
Bus Operation 9	1.2.4 AC Characteristics - Read-Only Operations 20
Command Definitions 10	1.2.5 AC Characteristics - Write Operations 24
Functions of Block Lock 12	1.2.6 Reset Operations..... 26
Status Register Definition..... 13	1.2.7 Block Erase, (Page Buffer) Program and Block Lock Configuration Performance..... 27
Extended Status Register Definition 14	2 Related Document Information 28
STS Configuration Definition 15	3 Package and packing specification..... 29

LH28F640SPHT-PTLZ8

64Mbit (4Mbit×16/8Mbit×8)

Page Mode Flash MEMORY

- 64-Mbit Density
 - Bit Organization ×8/×16
- High Performance Page Mode Reads for Memory Array
 - 120/25ns 4-Word/ 8-Byte Page Mode
- $V_{CC}=2.7V-3.6V$ Operation
 - V_{CCQ} for Input/Output Power Supply Isolation
 - Automatic Power Savings Mode reduces I_{CCR} in Static Mode
- OTP (One Time Program) Block
 - 4-Word/ 8-Byte Factory-Programmed Area
 - 3963-Word/ 7926-Byte User-Programmable Area
- High Performance Program with Page Buffer
 - 16-Word/ 32-Byte Page Buffer
 - Page Buffer Program Time 12.5 μ s/byte (Typ.)
- Operating Temperature -40°C to +85°C
- Symmetrically-Blocked Architecture
 - Sixty-four 64-KWord/ 128-KByte Blocks
- Enhanced Data Protection Features
 - Individual Block Lock
 - Absolute Protection with $V_{PEN} \leq V_{PENLK}$
 - Block Erase, (Page Buffer) Program Lockout during Power Transitions
- Automated Erase/Program Algorithms
 - Program Time 210 μ s (Typ.)
 - Block Erase Time 1s (Typ.)
- Cross-Compatible Command Support
 - Basic Command Set
 - Common Flash Interface (CFI)
- Extended Cycling Capability
 - Minimum 100,000 Block Erase Cycles
- 56-Lead TSOP (Normal Bend)
- CMOS Process (P-type silicon substrate)
- ETOXTM* Flash Technology
- Not designed or rated as radiation hardened

The product, which is Page Mode Flash memory, is a high density, low cost, nonvolatile read/write storage solution for a wide range of applications. The product can operate at $V_{CC}=2.7V-3.6V$ and $V_{PEN}=2.7V-3.6V$

The product supports high performance page mode. It allows code execution directly from Flash, thus eliminating time consuming wait states.

Fast program capability is provided through the use of high speed Page Buffer Program.

The block locking scheme is available for memory array and this scheme provides maximum flexibility for safe nonvolatile code and data storage.

OTP (One Time Program) block provides an area to store security code and to protect its code.

* ETOX is a trademark of Intel Corporation.

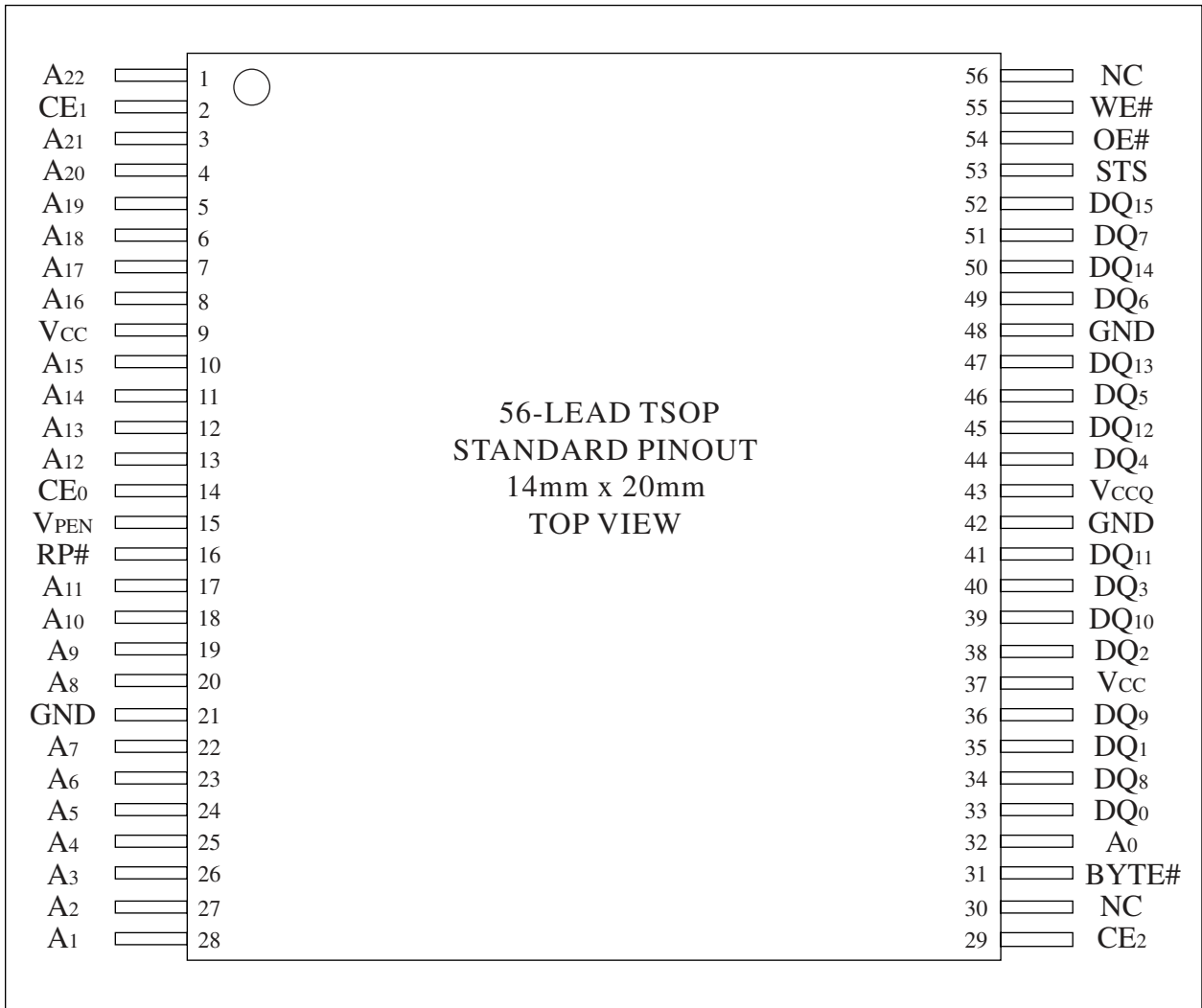

Figure 1. 56-Lead TSOP (Normal Bend) Pinout

Table 1. Pin Descriptions

Symbol	Type	Name and Function
A ₀	INPUT	ADDRESS INPUTS: Lowest address input in byte mode (BYTE#=V _{IL} : ×8 bit). Address is internally latched during an erase or a program cycle. This pin is not used in word mode (BYTE#=V _{IH} : ×16 bit)
A ₂₂ -A ₁	INPUT	ADDRESS INPUTS: Inputs for addresses during read, erase and program operations. Addresses are internally latched during an erase or a program cycle.
DQ ₁₅ -DQ ₀	INPUT/ OUTPUT	DATA INPUTS/OUTPUTS: Inputs data and commands during CUI (Command User Interface) write cycles, outputs data during memory array, status register, query code, identifier code reads. Data pins float to high-impedance (High Z) when the chip or outputs are deselected. Data is internally latched during an erase or program cycle. DQ ₁₅ -DQ ₈ pins are not used in byte mode (BYTE#=V _{IL} : ×8 bit).
CE ₀ , CE ₁ , CE ₂	INPUT	CHIP ENABLE: Activates the device's control logic, input buffers, decoders and sense amplifiers. When the device is de-selected, power consumption reduces to standby levels. Refer to Table 2 to determine whether the device is selected or de-selected depending on the state of CE ₀ , CE ₁ and CE ₂ .
RP#	INPUT	RESET: When low (V _{IL}), RP# resets internal automation and inhibits erase and program operations, which provides data protection. RP#-high (V _{IH}) enables normal operation. After power-up or reset mode, the device is automatically set to read array mode. RP# must be low during power-up/down.
OE#	INPUT	OUTPUT ENABLE: Gates the device's outputs during a read cycle.
WE#	INPUT	WRITE ENABLE: Controls writes to the CUI and array blocks. Addresses and data are latched on the first edge of CE ₀ , CE ₁ or CE ₂ that disables the device or the rising edge of WE# (whichever occurs first).
STS	OPEN DRAIN OUTPUT	STATUS: Indicates the status of the internal WSM (Write State Machine). When configured in level mode (default mode), STS acts as a RY/BY# pin (STS is V _{OL} when the WSM is executing internal erase or program algorithms). When configured in one of its pulse modes, STS can pulse to indicate erase/program completion. Refer to Table 9 for STS configuration.
BYTE#	INPUT	BYTE ENABLE: BYTE# V _{IL} places the device in byte mode (×8). In this mode, DQ ₁₅ -DQ ₈ is floated (High Z) and A ₀ is the lowest address input. BYTE# V _{IH} places the device in word mode (×16) and A ₁ is the lowest address input.
V _{PEN}	INPUT	MONITORING POWER SUPPLY VOLTAGE: V _{PEN} is not used for power supply pin. With V _{PEN} ≤ V _{PENLK} , block erase, (page buffer) program, block lock configuration and OTP program cannot be executed and should not be attempted.
V _{CC}	SUPPLY	DEVICE POWER SUPPLY (2.7V-3.6V): With V _{CC} ≤ V _{LKO} , all write attempts to the flash memory are inhibited. Device operations at invalid V _{CC} voltage (refer to DC Characteristics) produce spurious results and should not be attempted.
V _{CCQ}	SUPPLY	INPUT/OUTPUT POWER SUPPLY (2.7V-3.6V): Power supply for all input/output pins.
GND	SUPPLY	GROUND: Do not float any ground pins.
NC		NO CONNECT: Lead is not internally connected; it may be driven or floated.

Table 2. CE₀, CE₁, CE₂ Truth Table ⁽¹⁾

CE ₂	CE ₁	CE ₀	Device
V _{IL}	V _{IL}	V _{IL}	Enabled
V _{IL}	V _{IL}	V _{IH}	Disabled
V _{IL}	V _{IH}	V _{IL}	Disabled
V _{IL}	V _{IH}	V _{IH}	Disabled
V _{IH}	V _{IL}	V _{IL}	Enabled
V _{IH}	V _{IL}	V _{IH}	Enabled
V _{IH}	V _{IH}	V _{IL}	Enabled
V _{IH}	V _{IH}	V _{IH}	Disabled

NOTE:

1. For single-chip applications, CE₁ and CE₂ can be connected to GND.

[A ₂₂ -A ₁]	[A ₂₂ -A ₀]	[A ₂₂ -A ₁]	[A ₂₂ -A ₀]
3FFFFF	64-Kword/128-Kbyte Block 63	1FFFFF	64-Kword/128-Kbyte Block 31
3F0000		1F0000	
3EFFFF	64-Kword/128-Kbyte Block 62	1EFFFF	64-Kword/128-Kbyte Block 30
3E0000		1E0000	
3DFFFF	64-Kword/128-Kbyte Block 61	1DFFFF	64-Kword/128-Kbyte Block 29
3D0000		1D0000	
3CFFFF	64-Kword/128-Kbyte Block 60	1CFFFF	64-Kword/128-Kbyte Block 28
3C0000		1C0000	
3BFFFF	64-Kword/128-Kbyte Block 59	1BFFFF	64-Kword/128-Kbyte Block 27
3B0000		1B0000	
3AFFFF	64-Kword/128-Kbyte Block 58	1AFFFF	64-Kword/128-Kbyte Block 26
3A0000		1A0000	
39FFFF	64-Kword/128-Kbyte Block 57	19FFFF	64-Kword/128-Kbyte Block 25
390000		190000	
38FFFF	64-Kword/128-Kbyte Block 56	18FFFF	64-Kword/128-Kbyte Block 24
380000		180000	
37FFFF	64-Kword/128-Kbyte Block 55	17FFFF	64-Kword/128-Kbyte Block 23
370000		170000	
36FFFF	64-Kword/128-Kbyte Block 54	16FFFF	64-Kword/128-Kbyte Block 22
360000		160000	
35FFFF	64-Kword/128-Kbyte Block 53	15FFFF	64-Kword/128-Kbyte Block 21
350000		150000	
34FFFF	64-Kword/128-Kbyte Block 52	14FFFF	64-Kword/128-Kbyte Block 20
340000		140000	
33FFFF	64-Kword/128-Kbyte Block 51	13FFFF	64-Kword/128-Kbyte Block 19
330000		130000	
32FFFF	64-Kword/128-Kbyte Block 50	12FFFF	64-Kword/128-Kbyte Block 18
320000		120000	
31FFFF	64-Kword/128-Kbyte Block 49	11FFFF	64-Kword/128-Kbyte Block 17
310000		110000	
30FFFF	64-Kword/128-Kbyte Block 48	10FFFF	64-Kword/128-Kbyte Block 16
300000		100000	
2FFFFF	64-Kword/128-Kbyte Block 47	0FFFFF	64-Kword/128-Kbyte Block 15
2F0000		0F0000	
2EFFFF	64-Kword/128-Kbyte Block 46	0EFFFF	64-Kword/128-Kbyte Block 14
2E0000		0E0000	
2DFFFF	64-Kword/128-Kbyte Block 45	0DFFFF	64-Kword/128-Kbyte Block 13
2D0000		0D0000	
2CFFFF	64-Kword/128-Kbyte Block 44	0CFFFF	64-Kword/128-Kbyte Block 12
2C0000		0C0000	
2BFFFF	64-Kword/128-Kbyte Block 43	0BFFFF	64-Kword/128-Kbyte Block 11
2B0000		0B0000	
2AFFFF	64-Kword/128-Kbyte Block 42	0AFFFF	64-Kword/128-Kbyte Block 10
2A0000		0A0000	
29FFFF	64-Kword/128-Kbyte Block 41	09FFFF	64-Kword/128-Kbyte Block 9
290000		090000	
28FFFF	64-Kword/128-Kbyte Block 40	08FFFF	64-Kword/128-Kbyte Block 8
280000		080000	
27FFFF	64-Kword/128-Kbyte Block 39	07FFFF	64-Kword/128-Kbyte Block 7
270000		070000	
26FFFF	64-Kword/128-Kbyte Block 38	06FFFF	64-Kword/128-Kbyte Block 6
260000		060000	
25FFFF	64-Kword/128-Kbyte Block 37	05FFFF	64-Kword/128-Kbyte Block 5
250000		050000	
24FFFF	64-Kword/128-Kbyte Block 36	04FFFF	64-Kword/128-Kbyte Block 4
240000		040000	
23FFFF	64-Kword/128-Kbyte Block 35	03FFFF	64-Kword/128-Kbyte Block 3
230000		030000	
22FFFF	64-Kword/128-Kbyte Block 34	02FFFF	64-Kword/128-Kbyte Block 2
220000		020000	
21FFFF	64-Kword/128-Kbyte Block 33	01FFFF	64-Kword/128-Kbyte Block 1
210000		010000	
20FFFF	64-Kword/128-Kbyte Block 32	00FFFF	64-Kword/128-Kbyte Block 0
200000		000000	
	7FFFFF		3FFFFF
	7E0000		3E0000
	7DFFFF		3DFFFF
	7D0000		3D0000
	7CFFFF		3CFFFF
	7C0000		3C0000
	7BFFFF		3BFFFF
	7B0000		3B0000
	7AFFFF		3AFFFF
	7A0000		3A0000
	79FFFF		39FFFF
	790000		390000
	78FFFF		38FFFF
	780000		380000
	77FFFF		37FFFF
	770000		370000
	76FFFF		36FFFF
	760000		360000
	75FFFF		35FFFF
	750000		350000
	74FFFF		34FFFF
	740000		340000
	73FFFF		33FFFF
	730000		330000
	72FFFF		32FFFF
	720000		320000
	71FFFF		31FFFF
	710000		310000
	70FFFF		30FFFF
	700000		300000
	6FFFFF		2FFFFF
	6F0000		2F0000
	6EFFFF		2EFFFF
	6E0000		2E0000
	6DFFFF		2DFFFF
	6D0000		2D0000
	6CFFFF		2CFFFF
	6C0000		2C0000
	6BFFFF		2BFFFF
	6B0000		2B0000
	6AFFFF		2AFFFF
	6A0000		2A0000
	69FFFF		29FFFF
	690000		290000
	68FFFF		28FFFF
	680000		280000
	67FFFF		27FFFF
	670000		270000
	66FFFF		26FFFF
	660000		260000
	65FFFF		25FFFF
	650000		250000
	64FFFF		24FFFF
	640000		240000
	63FFFF		23FFFF
	630000		230000
	62FFFF		22FFFF
	620000		220000
	61FFFF		21FFFF
	610000		210000
	60FFFF		20FFFF
	600000		200000
	5FFFFF		1FFFFF
	5F0000		1F0000
	5EFFFF		1EFFFF
	5E0000		1E0000
	5DFFFF		1DFFFF
	5D0000		1D0000
	5CFFFF		1CFFFF
	5C0000		1C0000
	5BFFFF		1BFFFF
	5B0000		1B0000
	5AFFFF		1AFFFF
	5A0000		1A0000
	59FFFF		19FFFF
	590000		190000
	58FFFF		18FFFF
	580000		180000
	57FFFF		17FFFF
	570000		170000
	56FFFF		16FFFF
	560000		160000
	55FFFF		15FFFF
	550000		150000
	54FFFF		14FFFF
	540000		140000
	53FFFF		13FFFF
	530000		130000
	52FFFF		12FFFF
	520000		120000
	51FFFF		11FFFF
	510000		110000
	50FFFF		10FFFF
	500000		100000
	4FFFFF		0FFFFF
	4F0000		0F0000
	4EFFFF		0EFFFF
	4E0000		0E0000
	4DFFFF		0DFFFF
	4D0000		0D0000
	4CFFFF		0CFFFF
	4C0000		0C0000
	4BFFFF		0BFFFF
	4B0000		0B0000
	4AFFFF		0AFFFF
	4A0000		0A0000
	49FFFF		09FFFF
	490000		090000
	48FFFF		08FFFF
	480000		080000
	47FFFF		07FFFF
	470000		070000
	46FFFF		06FFFF
	460000		060000
	45FFFF		05FFFF
	450000		050000
	44FFFF		04FFFF
	440000		040000
	43FFFF		03FFFF
	430000		030000
	42FFFF		02FFFF
	420000		020000
	41FFFF		01FFFF
	410000		010000
	40FFFF		00FFFF
	400000		000000

Figure 2. Memory Map

Table 3. Identifier Codes Address

	Code	Address [A ₂₂ -A ₁] ⁽¹⁾	Data [DQ ₇ -DQ ₀]	Notes
Manufacturer Code	Manufacturer Code	000000H	B0H	2
Device Code	Device Code	000001H	17H	2
Block Lock Configuration Code	Block is Unlocked	Block Address + 2	DQ ₀ = 0	3
	Block is Locked		DQ ₀ = 1	3

NOTES:

1. The address A₀ don't care.
2. "00H" is presented on DQ₁₅-DQ₈ in word mode (BYTE#=V_{IH} : ×16 bit).
3. Block Address = The beginning location of a block address. DQ₁₅-DQ₁ are reserved for future implementation.

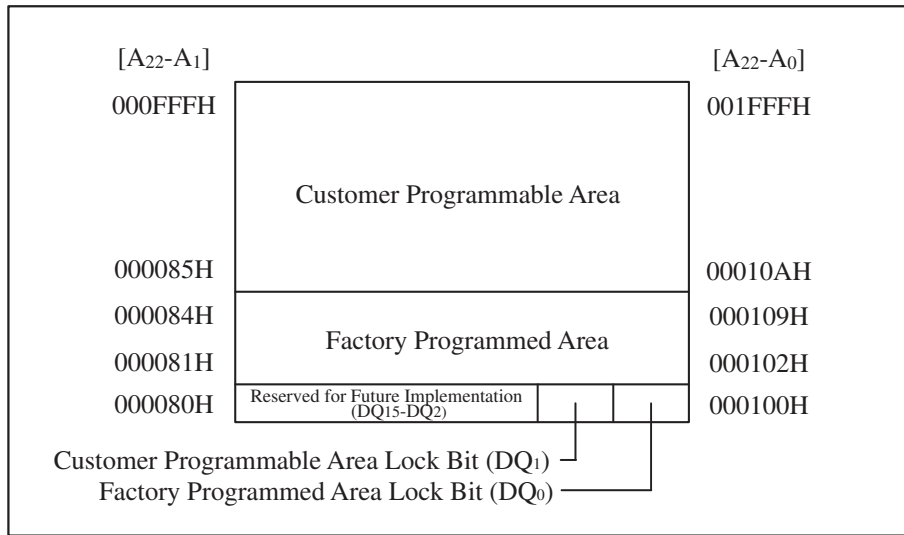

Figure 3. OTP Block Address Map
(The area not specified in the above figure cannot be used.)

Table 4. Bus Operation^(1, 2)

Mode	Notes	RP#	CE _{0,1,2} ⁽³⁾	OE#	WE#	Address	V _{PEN}	DQ ⁽⁴⁾	STS ⁽¹⁰⁾
Read Array	8	V _{IH}	Enabled	V _{IL}	V _{IH}	X	X	D _{OUT}	X
Output Disable		V _{IH}	Enabled	V _{IH}	V _{IH}	X	X	High Z	X
Standby		V _{IH}	Disabled	X	X	X	X	High Z	X
Reset	5	V _{IL}	X	X	X	X	X	High Z	High Z
Read Identifier Codes/OTP	8	V _{IH}	Enabled	V _{IL}	V _{IH}	Refer to Table 3	X	Refer to Table 3	X
Read Query	8,9	V _{IH}	Enabled	V _{IL}	V _{IH}	See Appendix	X	See Appendix	X
Write	6,7,8	V _{IH}	Enabled	V _{IH}	V _{IL}	X	X	D _{IN}	X

NOTES:

1. Refer to DC Characteristics. When $V_{PEN} \leq V_{PENLK}$, memory contents can be read, but cannot be altered.
2. X can be V_{IL} or V_{IH} for control pins and addresses, and V_{PENLK} or V_{PENH} for V_{PEN}. Refer to DC Characteristics for V_{PENLK} and V_{PENH} voltages.
3. Refer to Table 2 to determine whether the device is selected or de-selected depending on the state of CE₀, CE₁ and CE₂.
4. DQ refers to DQ₁₅-DQ₀ in word mode (BYTE#=V_{IH} : ×16 bit) and DQ₇-DQ₀ in byte mode (BYTE#=V_{IL} : ×8 bit).
5. RP# at GND±0.2V ensures the lowest power consumption.
6. Command writes involving block erase, (page buffer) program, block lock configuration or OTP program are reliably executed when V_{PEN}=V_{PENH} and V_{CC}=2.7V-3.6V.
7. Refer to Table 5 for valid D_{IN} during a write operation.
8. Never hold OE# low and WE# low at the same timing.
9. Refer to Appendix of LH28F640SP series for more information about query code.
10. STS is V_{OL} when the WSM (Write State Machine) is executing internal block erase, (page buffer) program or OTP program algorithms. It is High Z during when the WSM is not busy, in block erase suspend mode (with program and page buffer program inactive), (page buffer) program suspend mode, or reset mode.

Table 5. Command Definitions ⁽¹⁰⁾

Command	Bus Cycles Req'd	Notes	First Bus Cycle			Second Bus Cycle		
			Oper ⁽¹⁾	Addr ⁽²⁾	Data ⁽³⁾	Oper ⁽¹⁾	Addr ⁽²⁾	Data ⁽³⁾
Read Array	1		Write	X	FFH			
Read Identifier Codes/OTP	≥ 2	4	Write	X	90H	Read	IA or OA	ID or OD
Read Query	≥ 2	4	Write	X	98H	Read	QA	QD
Read Status Register	2		Write	X	70H	Read	X	SRD
Clear Status Register	1		Write	X	50H			
Block Erase	2	5	Write	BA	20H	Write	BA	D0H
Program	2	5,6	Write	X	40H or 10H	Write	WA	WD
Page Buffer Program	≥ 4	5,7	Write	BA	E8H	Write	BA	N-1
Block Erase and (Page Buffer) Program Suspend	1	8	Write	X	B0H			
Block Erase and (Page Buffer) Program Resume	1	8	Write	X	D0H			
STS Configuration	2		Write	X	B8H	Write	X	CC
Set Block Lock Bit	2		Write	X	60H	Write	BA	01H
Clear Block Lock Bits	2	9	Write	X	60H	Write	X	D0H
OTP Program	2		Write	X	C0H	Write	OA	OD

NOTES:

- Bus operations are defined in Table 4.
- X=Any valid address within the device.
IA=Identifier codes address (Refer to Table 3).
QA=Query codes address. Refer to Appendix of LH28F640SP series for details.
BA=Address within the block for block erase, page buffer program or set block lock bit.
WA=Address of memory location for the Program command.
OA=Address of OTP block to be read or programmed (Refer to Figure 3).
- The upper byte of the data bus (DQ₁₅-DQ₈) during command writes is ignored in word mode (BYTE#=V_{IH} : ×16 bit).
ID=Data to be read from identifier codes. (Refer to Table 3).
QD=Data to be read from query database. Refer to Appendix of LH28F640SP series for details.
SRD=Data to be read from status register. Refer to Table 7 for a description of the status register bits.
WD=Data to be programmed at location WA. Data is latched on the first edge of CE₀, CE₁ or CE₂ that disables the device or the rising edge of WE# (whichever occurs first) during command write cycles.
N-1=N is the number of the words /bytes to be loaded into a page buffer.
OD=Data within OTP block. Data is latched on the first edge of CE₀, CE₁ or CE₂ that disables the device or the rising edge of WE# (whichever occurs first) during command write cycles.
CC= STS configuration code (Refer to Table 9).
- Following the Read Identifier Codes/OTP command, read operations access manufacturer code, device code, block lock configuration code and the data within OTP block (Refer to Table 3).
The Read Query command is available for reading CFI (Common Flash Interface) information.
- Block erase or (page buffer) program cannot be executed when the selected block is locked. Unlocked block can be erased or programmed when RP# is V_{IH}.
- Either 40H or 10H are recognized by the CUI (Command User Interface) as the program setup.
- Following the third bus cycle, write the program sequential address and data of "N" times. Finally, write the any valid address within the block to be programmed and the confirm command (D0H).

Refer to Appendix of LH28F640SP series for details.

8. If both block erase operation and (page buffer) program operation are suspended, the suspended (page buffer) program operation is resumed when writing the Block Erase and (Page Buffer) Program Resume (D0H) command.
9. Following the Clear Block Lock Bits command, all the blocks are unlocked at a time.
10. Commands other than those shown above are reserved by SHARP for future device implementations and should not be used.

Table 6. Functions of Block Lock ^{(1), (2)}

DQ ₀ ⁽³⁾	State Name	Erase/Program Allowed ⁽⁴⁾
0	Unlocked	Yes
1	Locked	No

NOTES:

1. Selected block is locked by the Set Block Lock Bit command. Following the Clear Block Lock Bits command, all the blocks are unlocked at a time.
2. Locked and unlocked states remain unchanged even after power-up/down and device reset.
3. After writing the Read Identifier Codes/OTP command, read operation outputs the block lock bit status on DQ₀ (refer to Table 3).
4. Erase and program are general terms, respectively, to express: block erase and (page buffer) program operations.

Table 7. Status Register Definition

R	R	R	R	R	R	R	R
15	14	13	12	11	10	9	8
WSMS	BESS	BECBLS	PBPOPSBLS	VPENS	PBPSS	DPS	R
7	6	5	4	3	2	1	0

<p>SR.15 - SR.8 = RESERVED FOR FUTURE ENHANCEMENTS (R)</p> <p>SR.7 = WRITE STATE MACHINE STATUS (WSMS) 1 = Ready 0 = Busy</p> <p>SR.6 = BLOCK ERASE SUSPEND STATUS (BESS) 1 = Block Erase Suspended 0 = Block Erase in Progress/Completed</p> <p>SR.5 = BLOCK ERASE AND CLEAR BLOCK LOCK BITS STATUS (BECBLS) 1 = Error in Block Erase or Clear Block Lock Bits 0 = Successful Block Erase or Clear Block Lock Bits</p> <p>SR.4 = (PAGE BUFFER) PROGRAM, OTP PROGRAM AND SET BLOCK LOCK BIT STATUS (PBPOPSBLS) 1 = Error in (Page Buffer) Program, OTP Program or Set Block Lock Bit 0 = Successful (Page Buffer) Program, OTP Program or Set Block Lock Bit</p> <p>SR.3 = V_{PEN} STATUS (VPENS) 1 = V_{PEN} LOW Detect, Operation Abort 0 = V_{PEN} OK</p> <p>SR.2 = (PAGE BUFFER) PROGRAM SUSPEND STATUS (PBPSS) 1 = (Page Buffer) Program Suspended 0 = (Page Buffer) Program in Progress/Completed</p> <p>SR.1 = DEVICE PROTECT STATUS (DPS) 1 = Erase or Program Attempted on a Locked Block, Operation Abort 0 = Unlocked</p> <p>SR.0 = RESERVED FOR FUTURE ENHANCEMENTS (R)</p>	<p>NOTES:</p> <p>Check SR.7 or STS to determine block erase, (page buffer) program, block lock configuration or OTP program completion. SR.6 - SR.1 are invalid while SR.7="0".</p> <p>If both SR.5 and SR.4 are "1"s after a block erase, page buffer program, block lock configuration, STS configuration attempt, an improper command sequence was entered.</p> <p>SR.3 does not provide a continuous indication of V_{PEN} level. The WSM interrogates and indicates the V_{PEN} level only after Block Erase, (Page Buffer) Program, Set Block Lock Bit, Clear Block Lock Bits or OTP Program command sequences. SR.3 is not guaranteed to report accurate feedback when V_{PEN}≠V_{PENH} or V_{PENLK}.</p> <p>SR.1 does not provide a continuous indication of block lock bit. The WSM interrogates the block lock bit only after Block Erase, (Page Buffer) Program or OTP Program command sequences. It informs the system, depending on the attempted operation, if the block lock bit is set. Reading the block lock configuration codes after writing the Read Identifier Codes/OTP command indicates block lock bit status.</p> <p>SR.15 - SR.8 and SR.0 are reserved for future use and should be masked out when polling the status register.</p>
---	---

Table 8. Extended Status Register Definition

R	R	R	R	R	R	R	R
15	14	13	12	11	10	9	8
SMS	R	R	R	R	R	R	R
7	6	5	4	3	2	1	0

<p>XSR.15-8 = RESERVED FOR FUTURE ENHANCEMENTS (R)</p> <p>XSR.7 = STATE MACHINE STATUS (SMS) 1 = Page Buffer Program available 0 = Page Buffer Program not available</p> <p>XSR.6-0 =RESERVED FOR FUTURE ENHANCEMENTS (R)</p>	<p style="text-align: center;">NOTES:</p> <p>After issue a Page Buffer Program command (E8H), XSR.7="1" indicates that the entered command is accepted. If XSR.7 is "0", the command is not accepted and a next Page Buffer Program command (E8H) should be issued again to check if page buffer is available or not.</p> <p>XSR.15-8 and XSR.6-0 are reserved for future use and should be masked out when polling the extended status register.</p>
---	---

Table 9. STS Configuration Definition ⁽¹⁾

R	R	R	R	R	R	R	R
15	14	13	12	11	10	9	8
R	R	R	R	R	R	CC	CC
7	6	5	4	3	2	1	0

<p>DQ₁₅-DQ₂ = RESERVED FOR FUTURE ENHANCEMENTS (R)</p> <p>DQ₁-DQ₀ = STS CONFIGURATION CODE (CC) 00 = level mode: RY/BY# indication. (Default) 01 = pulse mode on erase complete. 10 = pulse mode on program complete. 11 = pulse mode on erase or program complete.</p> <p>In STS configuration = "00", STS is V_{OL} when the WSM is executing internal erase or program algorithms.</p> <p>STS configuration codes "01", "10" and "11" are all pulse modes such that the STS pin pulses low then high when the operation indicated by the configuration code is completed.</p>	<p>NOTES:</p> <p>After power-up or device reset, STS configuration is set to "00".</p> <p>STS configuration 00 The output of the STS pin is the control signal to prevent accessing a flash memory while the internal WSM is busy (SR.7="0").</p> <p>STS configuration 01 The output of the STS pin is the control signal to indicate that the erase operation is completed and the flash memory is available for the next operation.</p> <p>STS configuration 10 The output of the STS pin is the control signal to indicate that the program operation is completed and the flash memory is available for the next operation.</p> <p>STS configuration 11 The output of the STS pin is the control signal to indicate that the erase or program operation is completed and the flash memory is available for the next operation.</p>
--	--

NOTE:

1. When the device is configured in one of the pulse modes, the STS pin pulses low with a typical pulse width of 250ns.

1 Electrical Specifications

1.1 Absolute Maximum Ratings *

Operating Temperature

During Read, Erase and Program ...-40°C to +85°C ⁽¹⁾

Storage Temperature

During under Bias..... -40°C to +85°C
 During non Bias..... -65°C to +125°C

Voltage On Any Pin (except V_{CC}, V_{CCQ} and V_{PEN})

..... -0.5V to V_{CCQ}+0.5V ⁽²⁾

V_{CC} and V_{CCQ} Supply Voltage -0.2V to +3.9V ⁽²⁾

V_{PEN} Supply Voltage..... -0.2V to +3.9V ⁽²⁾

Output Short Circuit Current 100mA ⁽³⁾

***WARNING:** Stressing the device beyond the "Absolute Maximum Ratings" may cause permanent damage. These are stress ratings only. Operation beyond the "Operating Conditions" is not recommended and extended exposure beyond the "Operating Conditions" may affect device reliability.

NOTES:

1. Operating temperature is for extended temperature product defined by this specification.
2. All specified voltages are with respect to GND. Minimum DC voltage is -0.5V on input/output pins and -0.2V on V_{CC}, V_{CCQ} and V_{PEN} pins. During transitions, this level may undershoot to -2.0V for periods <20ns. Maximum DC voltage on input/output pins is V_{CC}+0.5V which, during transitions, may overshoot to V_{CC}+2.0V for periods <20ns.
3. Output shorted for no more than one second. No more than one output shorted at a time.

1.2 Operating Conditions

Symbol	Parameter	Notes	Min.	Typ.	Max.	Unit	Test Conditions
T _A	Operating Temperature		-40	+25	+85	°C	Ambient Temperature
V _{CC}	V _{CC} Supply Voltage	1, 2	2.7	3.0	3.6	V	
V _{CCQ}	I/O Supply Voltage	1, 2	2.7	3.0	3.6	V	
V _{PENH}	V _{PEN} Voltage	1	2.7	3.0	3.6	V	
	Block Erase Cycling: V _{PEN} =V _{PENH}		100,000			Cycles	

NOTES:

1. Refer to DC Characteristics tables for voltage range-specific specification.
2. V_{CC} and V_{CCQ} should be the same voltage.

1.2.1 Capacitance ⁽¹⁾ ($T_A=+25^\circ\text{C}$, $f=1\text{MHz}$)

Symbol	Parameter	Min.	Typ.	Max.	Unit	Condition
C_{IN}	Input Capacitance		6	8	pF	$V_{IN}=0.0\text{V}$
C_{OUT}	Output Capacitance		8	12	pF	$V_{OUT}=0.0\text{V}$

NOTE:

1. Sampled, not 100% tested.

1.2.2 AC Input/Output Test Conditions

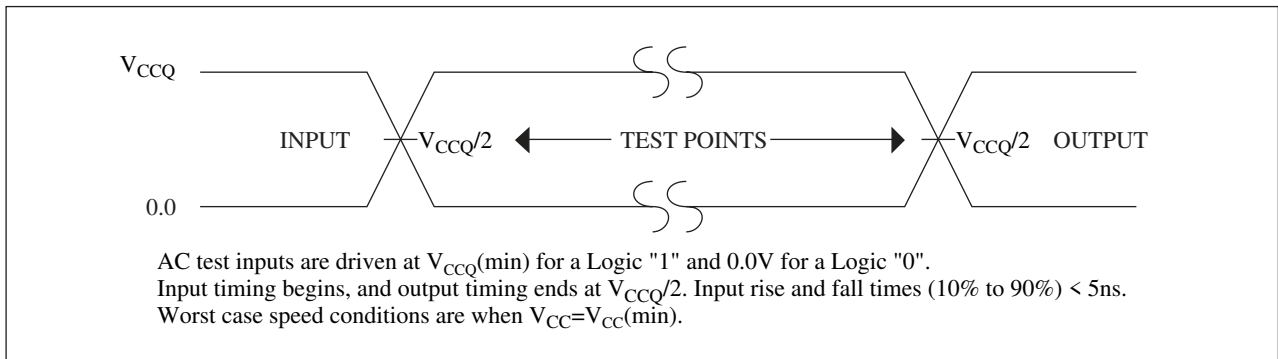

Figure 4. Transient Input/Output Reference Waveform for $V_{CC}=2.7\text{V}-3.6\text{V}$

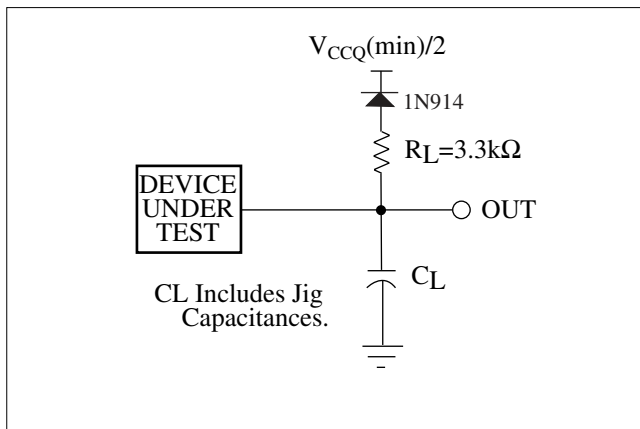

Figure 5. Transient Equivalent Testing Load Circuit

Table 10. Configuration Capacitance Loading Value

Test Configuration	C_L (pF)
$V_{CC}=2.7\text{V}-3.6\text{V}$	30

1.2.3 DC Characteristics

$V_{CC}=2.7V-3.6V$

Symbol	Parameter		Notes	Min.	Typ.	Max.	Unit	Test Conditions
I_{LI}	Input Load Current		1	-1		+1	μA	$V_{CC}=V_{CCMax.}$,
I_{LO}	Output Leakage Current		1	-10		+10	μA	$V_{CCQ}=V_{CCQMax.}$, $V_{IN}/V_{OUT}=V_{CCQ}$ or GND
I_{CCS}	V_{CC} Standby Current		1, 2, 8		50	120	μA	CMOS Inputs, $V_{CC}=V_{CCMax.}$, $V_{CCQ}=V_{CCQMax.}$, Device is disabled (refer to Table 2), $RP\#=V_{CCQ}\pm 0.2V$
					0.71	2	mA	TTL Inputs, $V_{CC}=V_{CCMax.}$, $V_{CCQ}=V_{CCQMax.}$, Device is disabled (refer to Table 2), $RP\#=V_{IH}$
I_{CCAS}	V_{CC} Automatic Power Savings Current		1, 2, 5		50	120	μA	CMOS Inputs, $V_{CC}=V_{CCMax.}$, $V_{CCQ}=V_{CCQMax.}$, Device is enabled (refer to Table 2)
I_{CCD}	V_{CC} Reset Current		1		50	120	μA	$RP\#=GND\pm 0.2V$ $I_{OUT}(STS)=0mA$
I_{CCR}	Average V_{CC} Page Mode Read Current	4 word/ 8 byte read	1, 2		15	20	mA	CMOS Inputs, $V_{CC}=V_{CCMax.}$, $V_{CCQ}=V_{CCQMax.}$, Device is enabled (refer to Table 2), $f=5MHz$, $I_{OUT}=0mA$
			1, 2		24	29	mA	CMOS Inputs, $V_{CC}=V_{CCMax.}$, $V_{CCQ}=V_{CCQMax.}$, Device is enabled (refer to Table 2), $f=33MHz$, $I_{OUT}=0mA$
	Average V_{CC} Read Current	1 word/ 1 byte read	1, 2		40	50	mA	CMOS Inputs, $V_{CC}=V_{CCMax.}$, $V_{CCQ}=V_{CCQMax.}$, Device is enabled (refer to Table 2), $f=5MHz$, $I_{OUT}=0mA$
I_{CCW}	V_{CC} (Page Buffer) Program, Set Block Lock Bit Current		1, 2, 6		35	60	mA	CMOS Inputs, $V_{PEN}=V_{PENH}$
			1, 2, 6		40	70	mA	TTL Inputs, $V_{PEN}=V_{PENH}$

DC Characteristics (Continued)

 $V_{CC}=2.7V-3.6V$

Symbol	Parameter	Notes	Min.	Typ.	Max.	Unit	Test Conditions
I_{CCCE}	V_{CC} Block Erase, Clear Block Lock Bits Current	1, 2, 6		35	70	mA	CMOS Inputs, $V_{PEN}=V_{PENH}$
		1, 2, 6		40	80	mA	TTL Inputs, $V_{PEN}=V_{PENH}$
I_{CCWS} I_{CCES}	V_{CC} (Page Buffer) Program or Block Erase Suspend Current	1, 3			10	mA	Device is disabled (refer to Table 2).
V_{IL}	Input Low Voltage	6	-0.5		0.8	V	
V_{IH}	Input High Voltage	6	2.0		$V_{CCQ} + 0.5$	V	
V_{OL}	Output Low Voltage	6, 8			0.4	V	$V_{CC}=V_{CCMin.}$, $V_{CCQ}=V_{CCQMin.}$, $I_{OL}=2mA$
					0.2	V	$V_{CC}=V_{CCMin.}$, $V_{CCQ}=V_{CCQMin.}$, $I_{OL}=100\mu A$
V_{OH}	Output High Voltage	6, 8	$0.85 \times V_{CCQ}$			V	$V_{CC}=V_{CCMin.}$, $V_{CCQ}=V_{CCQMin.}$, $I_{OH}=-1.5mA$
			$V_{CCQ} - 0.2$			V	$V_{CC}=V_{CCMin.}$, $V_{CCQ}=V_{CCQMin.}$, $I_{OH}=-100\mu A$
V_{PENLK}	V_{PEN} Lockout Voltage during Normal Operations	4, 6, 7			1.0	V	
V_{PENH}	V_{PEN} Voltage during Block Erase, (Page Buffer) Program, Set Block Lock Bit, Clear Block Lock Bits or OTP Program Operations	4, 7	2.7	3.0	3.6	V	
V_{LKO}	V_{CC} Lockout Voltage	4	2.0			V	

NOTES:

- All currents are in RMS unless otherwise noted. Typical values are the reference values at $V_{CC}=3.0V$, $V_{CCQ}=3.0V$ and $T_A=+25^\circ C$ unless V_{CC} is specified.
- CMOS inputs are either $V_{CCQ} \pm 0.2V$ or $GND \pm 0.2V$. TTL inputs are either V_{IL} or V_{IH} .
- I_{CCWS} and I_{CCES} are specified with the device de-selected. If read or (page buffer) program is executed while in block erase suspend mode, the device's current draw is the sum of I_{CCES} and I_{CCR} or I_{CCW} . If read is executed while in (page buffer) program suspend mode, the device's current draw is the sum of I_{CCWS} and I_{CCR} .
- Block erase, (page buffer) program, block lock configuration and OTP program operations are inhibited when $V_{PEN} \leq V_{PENLK}$ or $V_{CC} \leq V_{LKO}$. These operations are not guaranteed outside the specified voltage ($V_{CC}=2.7V-3.6V$ and $V_{PEN}=2.7V-3.6V$).
- The Automatic Power Savings (APS) feature automatically places the device in power save mode after read cycle completion. Standard address access timings (t_{AVQV}) provide new data when addresses are changed.
- Sampled, not 100% tested.
- V_{PEN} is not used for power supply pin. With $V_{PEN} \leq V_{PENLK}$, block erase, (page buffer) program, block lock configuration and OTP program operations are inhibited.
- Includes STS.

1.2.4 AC Characteristics - Read-Only Operations ⁽¹⁾ $T_A = -40^\circ\text{C}$ to $+85^\circ\text{C}$

Symbol	Parameter	Notes	V_{CC}		V_{CCQ}		Unit
			3.0V-3.6V	2.7V-3.6V	3.0V-3.6V	2.7V-3.6V	
t_{AVAV}	Read Cycle Time		120		120		ns
t_{AVQV}	Address to Output Delay			120		120	ns
t_{ELQV}	CE_X to Output Delay	3, 4		120		120	ns
t_{APA}	Page Address Access Time			25		30	ns
t_{GLQV}	OE# to Output Delay	3		25		30	ns
t_{PHQV}	RP# High to Output Delay			180		180	ns
t_{ELQX}	CE_X to Output in Low Z	2, 4	0		0		ns
t_{GLQX}	OE# to Output in Low Z	2	0		0		ns
t_{EHQZ}	CE_X to Output in High Z	2, 5		35		35	ns
t_{GHQZ}	OE# to Output in High Z	2		15		15	ns
t_{OH}	Output Hold from First Occurring Address, CE_X or OE# change	2, 5	0		0		ns
t_{ELFL}/t_{ELFH}	CE_X Setup to BYTE# Going Low or High	2, 4		10		10	ns
t_{FLQV}/t_{FHQV}	BYTE# to Output Delay			1000		1000	ns
t_{FLQZ}/t_{FHQZ}	BYTE# to Output in High Z	2		1000		1000	ns

NOTES:

1. Refer to AC input/output reference waveform for timing measurements and maximum allowable input slew rate.
2. Sampled, not 100% tested.
3. OE# may be delayed up to $t_{ELQV} - t_{GLQV}$ after the first edge of CE_0 , CE_1 or CE_2 that enables the device (refer to Table 2) without impact to t_{ELQV} .
4. The timing is defined from the first edge of CE_0 , CE_1 or CE_2 that enables the device.
5. The timing is defined from the first edge of CE_0 , CE_1 or CE_2 that disables the device.

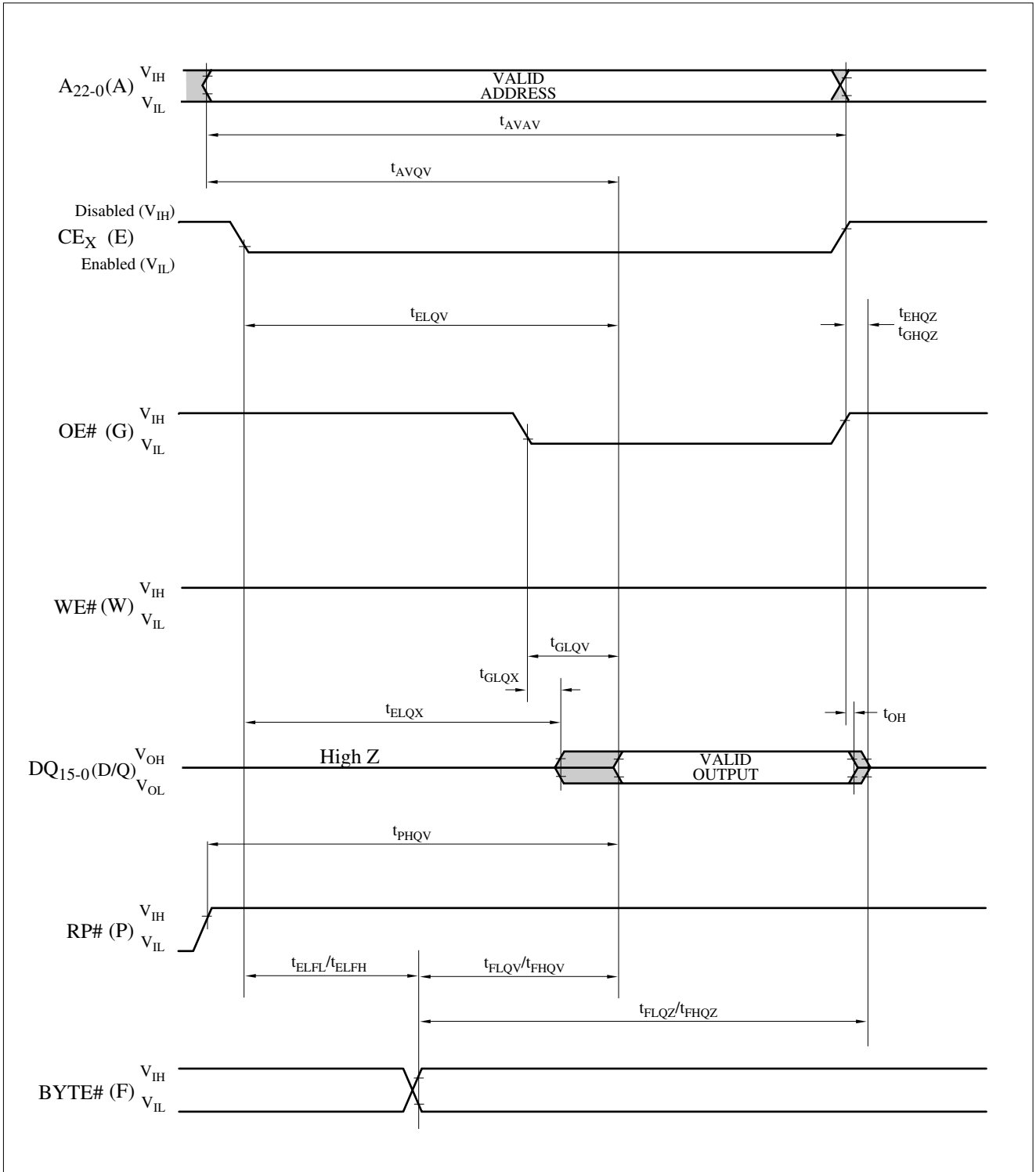

Figure 6. AC Waveform for 1-Word/ 1-Byte Read Operations
(Status Register, Identifier Codes, OTP Block or Query Code)

NOTE:

1. Status register, identifier codes, OTP block and query code can only be read in 1-word/ 1-byte read operations.

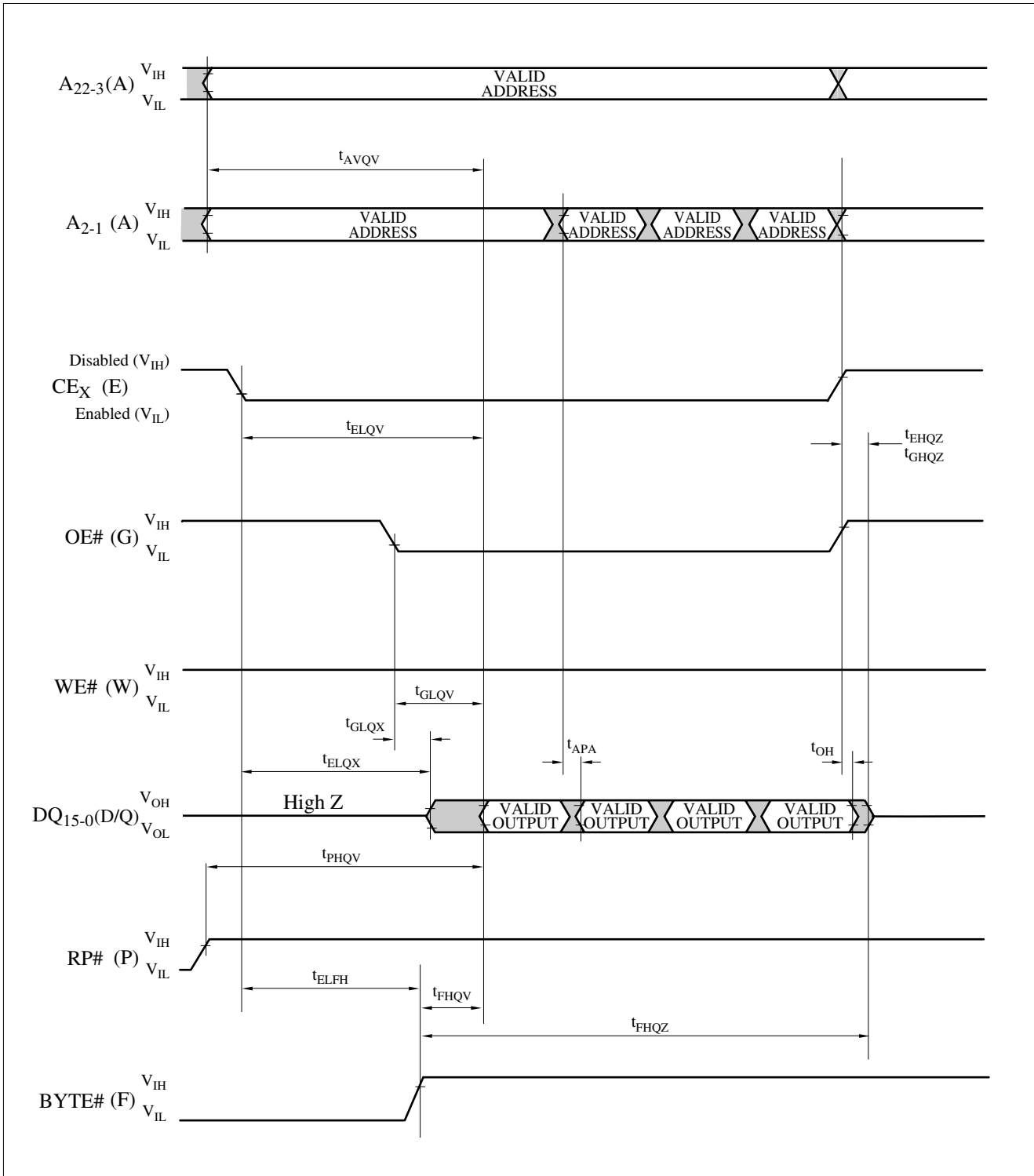

Figure 7. AC Waveform for 4-Word Page Mode Read Operations (Memory Array)

NOTE:

1. Memory array supports page mode read operations.

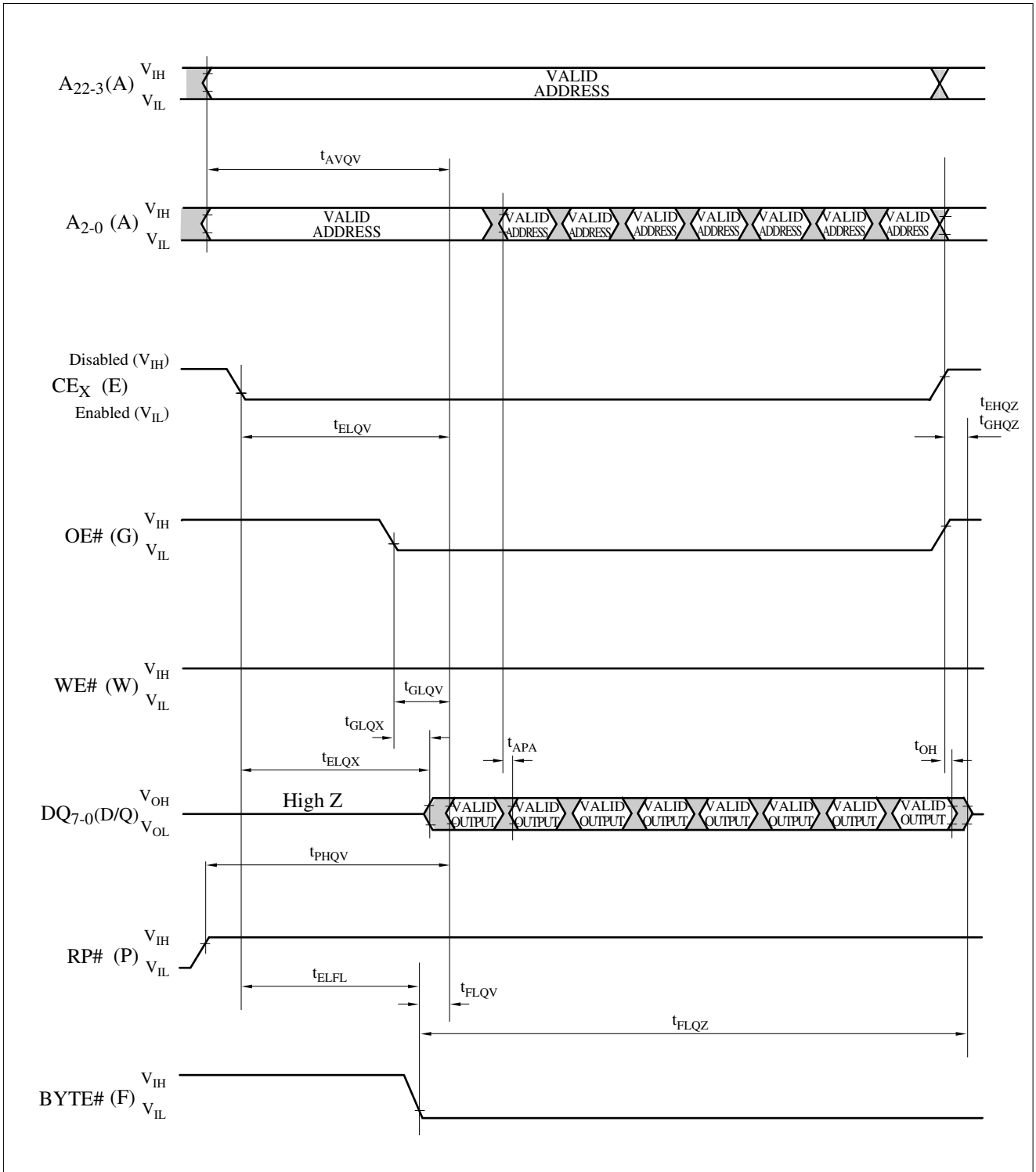

Figure 8. AC Waveform for 8-Byte Page Mode Read Operations (Memory Array)

NOTE:

1. Memory array supports page mode read operations.

1.2.5 AC Characteristics - Write Operations ^{(1), (2)}

$$V_{CC}=2.7V-3.6V, T_A=-40^{\circ}C \text{ to } +85^{\circ}C$$

Symbol	Parameter	Notes	Min.	Max.	Unit
t_{AVAV}	Write Cycle Time		120		ns
t_{PHWL} (t_{PHEL})	RP# High Recovery to WE# (CE_X) Going Low	3, 9	1		μ s
t_{ELWL} (t_{WLEL})	CE_X (WE#) Setup to WE# (CE_X) Going Low	9	0		ns
t_{WLWH} (t_{ELEH})	WE# (CE_X) Pulse Width Low	4, 9, 10	70		ns
t_{DVVH} (t_{DVEH})	Data Setup to WE# (CE_X) Going High	7, 10	50		ns
t_{AVVH} (t_{AVEH})	Address Setup to WE# (CE_X) Going High	7, 10	55		ns
t_{WHEH} (t_{EHWH})	CE_X (WE#) Hold from WE# (CE_X) High	10	0		ns
t_{WHDX} (t_{EHDX})	Data Hold from WE# (CE_X) High	10	0		ns
t_{WHAX} (t_{EHAX})	Address Hold from WE# (CE_X) High	10	0		ns
t_{WHWL} (t_{EHEL})	WE# (CE_X) Pulse Width High	5, 9, 10	30		ns
t_{VVVH} (t_{VVEH})	V_{PEN} Setup to WE# (CE_X) Going High	3, 10	0		ns
t_{WHGL} (t_{EHGL})	Write Recovery before Read	8	35		ns
t_{WHR0} (t_{EHR0}) t_{WHRL} (t_{EHL})	WE# (CE_X) High to SR.7 Going "0", STS Going Low	10, 11		500	ns
t_{QVVL}	V_{PEN} Hold from Valid SRD, STS High Z	3, 6, 11	0		ns
t_{FLWH}/t_{FHWL} (t_{FLEH}/t_{FHEH})	BYTE# Setup to WE# (CE_X) Going High	10	50		ns
t_{WHFL}/t_{WHFH} (t_{EHFL}/t_{EHFH})	BYTE# Hold from WE# (CE_X) High	10	90		ns

NOTES:

- The timing characteristics for reading the status register during block erase, (page buffer) program, block lock configuration and OTP program operations are the same as during read-only operations. Refer to AC Characteristics for read-only operations.
- A write operation can be initiated and terminated with either CE_0 , CE_1 , CE_2 or WE#.
- Sampled, not 100% tested.
- Write pulse width low (t_{WP}) is defined from the first edge of CE_0 , CE_1 or CE_2 that enables the device or the falling edge of WE# (whichever occurs last) to the first edge of CE_0 , CE_1 or CE_2 that disables the device or the rising edge of WE# (whichever occurs first). Hence, $t_{WP}=t_{WLWH}=t_{ELEH}=t_{WLEH}=t_{ELWH}$.
- Write pulse width high (t_{WPH}) is defined from the first edge of CE_0 , CE_1 or CE_2 that disables the device or the rising edge of WE# (whichever occurs first) to the first edge of CE_0 , CE_1 or CE_2 that enables the device or the falling edge of WE# (whichever occurs last). Hence, $t_{WPH}=t_{WHWL}=t_{EHEL}=t_{WHEL}=t_{EHWL}$.
- V_{PEN} should be held at $V_{PEN}=V_{PENH}$ until determination of block erase, (page buffer) program, block lock configuration or OTP program success (SR.1/3/4/5=0).
- Refer to Table 5 for valid address and data for block erase, (page buffer) program, block lock configuration and OTP program.
- The output delay time t_{AVQV} or t_{ELQV} is required in addition to t_{WHGL} (t_{EHGL}) for read operations after command writes.
- The timing is defined from the first edge of CE_0 , CE_1 or CE_2 that enables the device.
- The timing is defined from the first edge of CE_0 , CE_1 or CE_2 that disables the device.
- STS timings depend on STS configuration.

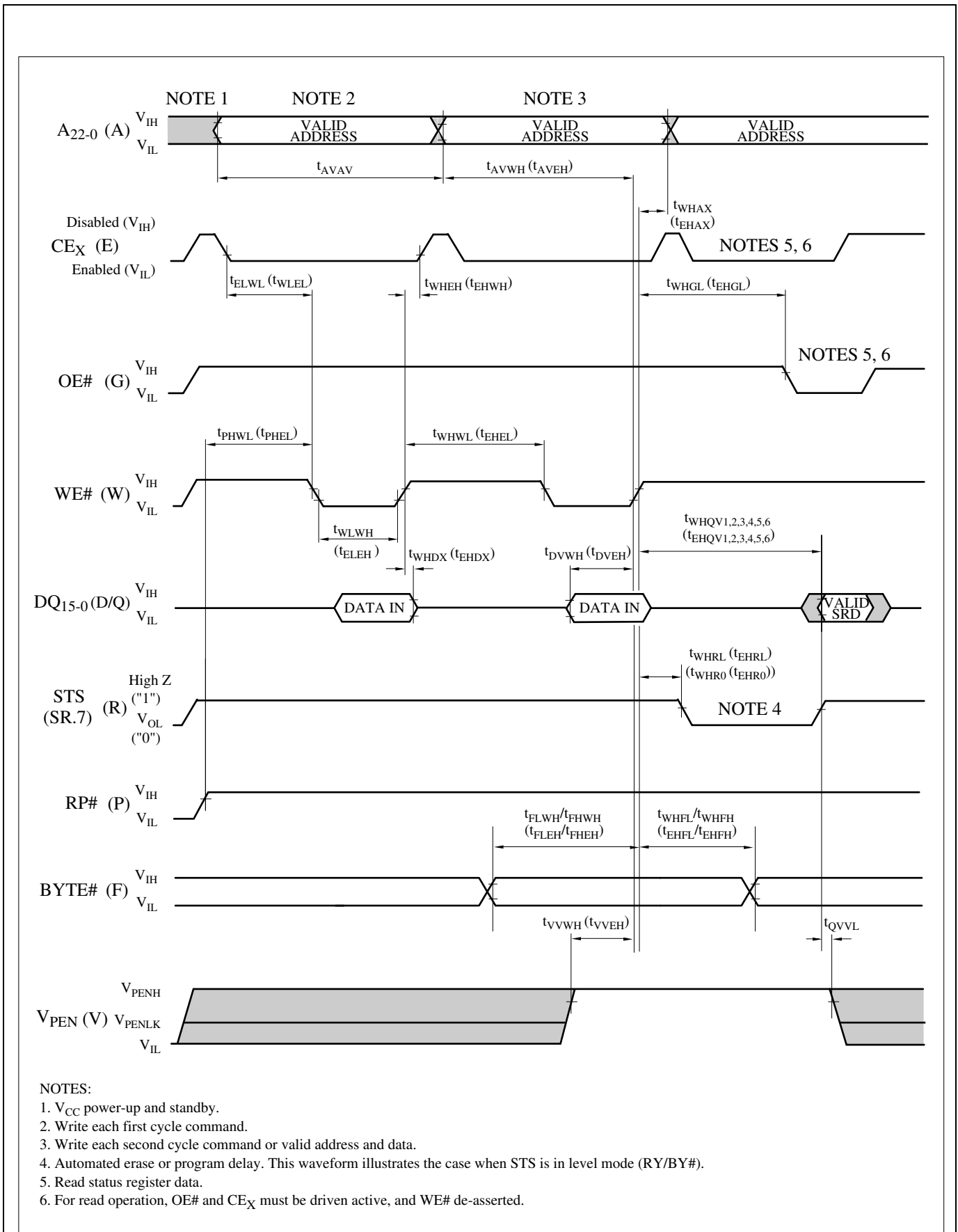

Figure 9. AC Waveform for Write Operations

1.2.6 Reset Operations

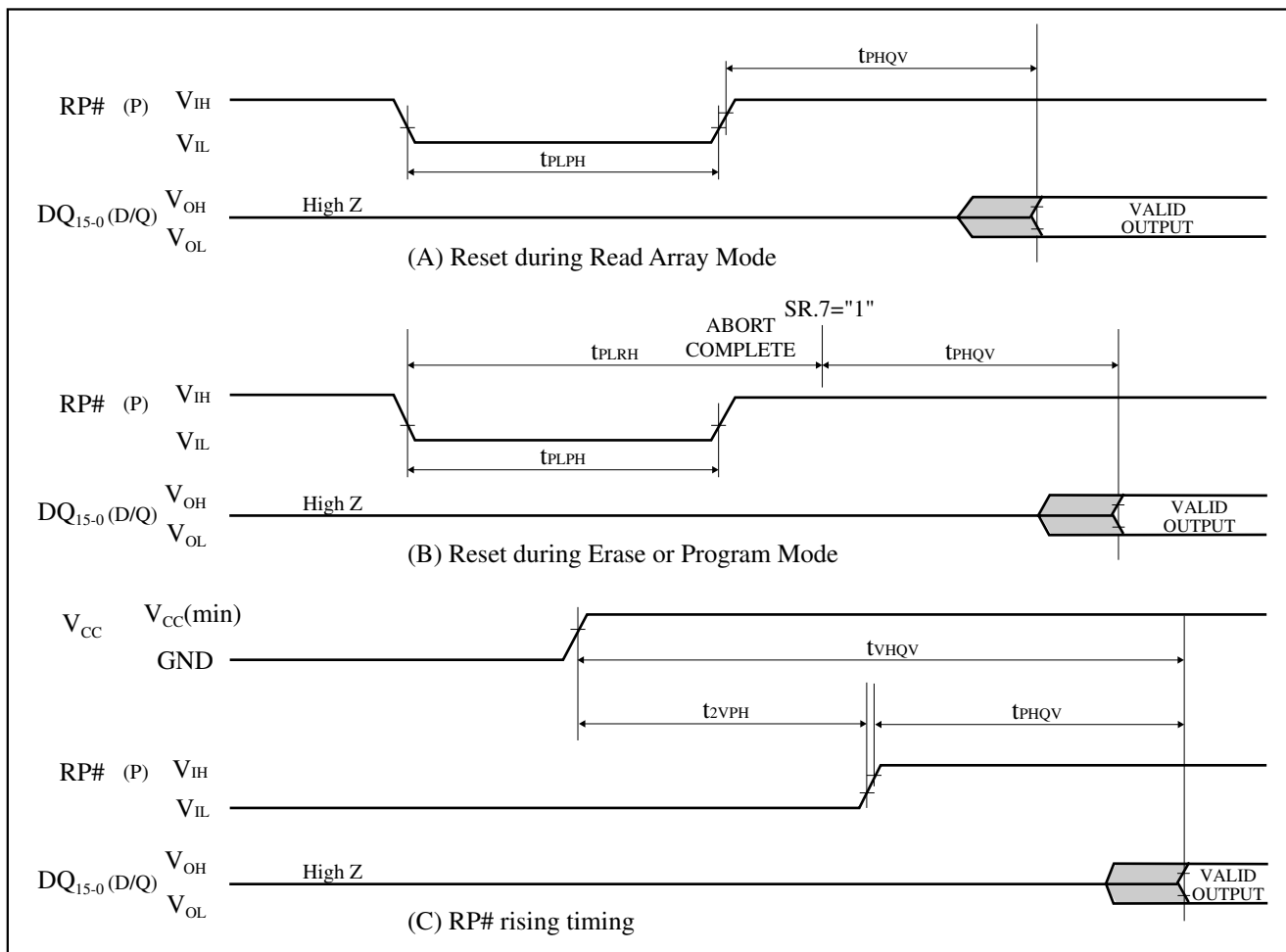

Figure 10. AC Waveform for Reset Operations

Reset AC Specifications ($V_{CC}=2.7V-3.6V$, $T_A=-40^{\circ}C$ to $+85^{\circ}C$)

Symbol	Parameter	Notes	Min.	Max.	Unit
t_{PLPH}	RP# Low to Reset during Read (RP# must be low during power-up.)	1, 2, 3	100		ns
t_{PLRH}	RP# Low to Reset during Erase or Program	1, 3, 4		30	μs
t_{2VPH}	V_{CC} 2.7V to RP# High	1, 3, 5	100		ns
t_{VHQV}	V_{CC} 2.7V to Output Delay	3		1	ms

NOTES:

1. A reset time, t_{PHQV} , is required from the later of SR.7 (STS) going "1" (High Z) or RP# going high until outputs are valid. Refer to AC Characteristics - Read-Only Operations for t_{PHQV} .
2. The device may reset if t_{PLPH} is $<100ns$, but this is not guaranteed.
3. Sampled, not 100% tested.
4. If RP# asserted while a block erase, (page buffer) program, block lock configuration or OTP program operation is not executing, the reset will complete within 100ns.
5. When the device power-up, holding RP# low minimum 100ns is required after V_{CC} has been in predefined range and also has been in stable there.

1.2.7 Block Erase, (Page Buffer) Program and Block Lock Configuration Performance⁽³⁾

$$V_{CC}=2.7V-3.6V, T_A=-40^{\circ}C \text{ to } +85^{\circ}C$$

Symbol	Parameter	Notes	$V_{PEN}=V_{PENH}$			Unit
			Min.	Typ. ⁽¹⁾	Max.	
	Page Buffer Program Time (Time to Program 16 words/ 32 bytes)	2, 6, 7		400	1200	μs
$t_{WHQV3}/$ t_{EHQV3}	Program Time	2		210	630	μs
	Block Program Time (Using Page Buffer Program Command)	2		1.6	4.8	s
$t_{WHQV4}/$ t_{EHQV4}	Block Erase Time	2		1	5	s
$t_{WHQV5}/$ t_{EHQV5}	Set Block Lock Bit Time	2		64	85	μs
$t_{WHQV6}/$ t_{EHQV6}	Clear Block Lock Bits Time	2		0.5	0.7	s
$t_{WHRH1}/$ t_{EHRH1}	(Page Buffer) Program Suspend Latency Time to Read	4		25	90	μs
$t_{WHRH2}/$ t_{EHRH2}	Block Erase Suspend Latency Time to Read	4		26	40	μs
t_{ERES}	Latency Time from Block Erase Resume Command to Block Erase Suspend Command	5	600			μs

NOTES:

1. Typical values measured at $V_{CC}=3.0V$, $V_{PEN}=3.0V$ and $T_A=+25^{\circ}C$. Assumes corresponding lock bits are not set. Subject to change based on device characterization.
2. Excludes external system-level overhead.
3. Sampled, but not 100% tested.
4. A latency time is required from writing suspend command (the first edge of CE_0 , CE_1 or CE_2 that disables the device or the rising edge of $WE\#$) until $SR.7$ going "1" or STS going High Z.
5. If the interval time from a Block Erase Resume command to a subsequent Block Erase Suspend command is shorter than t_{ERES} and its sequence is repeated, the block erase operation may not be finished.
6. These values are valid when the page buffer is full, and the start address is aligned on a 16-word/ 32-byte boundary.
7. Program time per byte (t_{WHQV1}/ t_{EHQV1}) is 12.5 μs /byte (typical).
Program time per word (t_{WHQV2}/ t_{EHQV2}) is 25.0 μs /word (typical).

2 Related Document Information⁽¹⁾

Document No.	Document Name
FUM03201	LH28F640SP series Appendix

NOTE:

1. International customers should contact their local SHARP or distribution sales offices.

3 Package and packing specification

[Applicability]

This specification applies to IC package of the LEAD-FREE delivered as a standard specification.

1. Storage Conditions.

1-1. Storage conditions required before opening the dry packing.

- Normal temperature : 5~40°C
- Normal humidity : 80%(Relative humidity) max.
- "Humidity" means "Relative humidity"

1-2. Storage conditions required after opening the dry packing.

In order to prevent moisture absorption after opening, ensure the following storage conditions apply:

- (1) Storage conditions for one-time soldering. (Convection reflow^{*1}, IR/Convection reflow.^{*1}, or Manual soldering.)
 - Temperature : 5~25°C
 - Humidity : 60% max.
 - Period : 96 hours max. after opening.
- (2) Storage conditions for two-time soldering. (Convection reflow^{*1}, IR/Convection reflow.^{*1})
 - a. Storage conditions following opening and prior to performing the 1st reflow.
 - Temperature : 5~25°C
 - Humidity : 60% max.
 - Period : 96 hours max. after opening.
 - b. Storage conditions following completion of the 1st reflow and prior to performing the 2nd reflow.
 - Temperature : 5~25°C
 - Humidity : 60% max.
 - Period : 96 hours max. after completion of the 1st reflow.

*1: Air or nitrogen environment.

1-3. Temporary storage after opening.

To re-store the devices before soldering, do so only once and use a dry box or place desiccant (with a blue humidity indicator) with the devices and perform dry packing again using heat-sealing.

The storage period, temperature and humidity must be as follows :

(1) Storage temperature and humidity.

※1 : External atmosphere temperature and humidity of the dry packing.

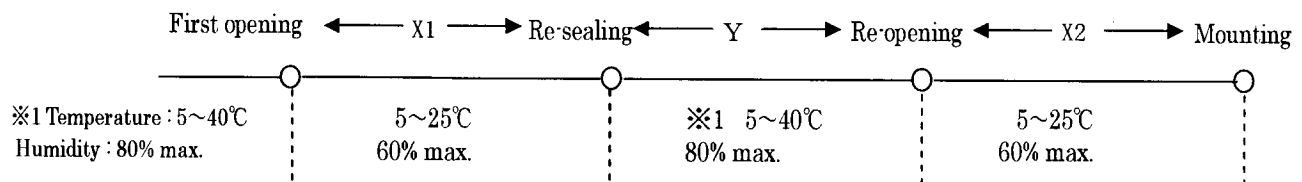

(2) Storage period.

- X1 + X2 : Refer to Section 1-2(1) and (2)a , depending on the mounting method.
- Y : Two weeks max.

2. Baking Condition.

(1) Situations requiring baking before mounting.

- Storage conditions exceed the limits specified in Section 1-2 or 1-3.
- Humidity indicator in the desiccant was already red (pink) when opened.
(Also for re-opening.)

(2) Recommended baking conditions.

- Baking temperature and period :
120°C for 16~24 hours.
- The above baking conditions apply since the trays are heat-resistant.

(3) Storage after baking.

- After baking, store the devices in the environment specified in Section 1-2 and mount immediately.

3. Surface mount conditions.

The following soldering condition are recommended to ensure device quality.

3-1.Soldering.

(1) Convection reflow or IR/Convection. (one-time soldering or two-time soldering in air or nitrogen environment)

- Temperature and period :

A) Peak temperature.	250°C max.
B) Heating temperature.	40 to 60 seconds as 220°C
C) Preheat temperature.	It is 150 to 200°C, and is 120±30 seconds
D) Temperature increase rate.	It is 1 to 3°C/seconds
- Measuring point : IC package surface.
- Temperature profile:

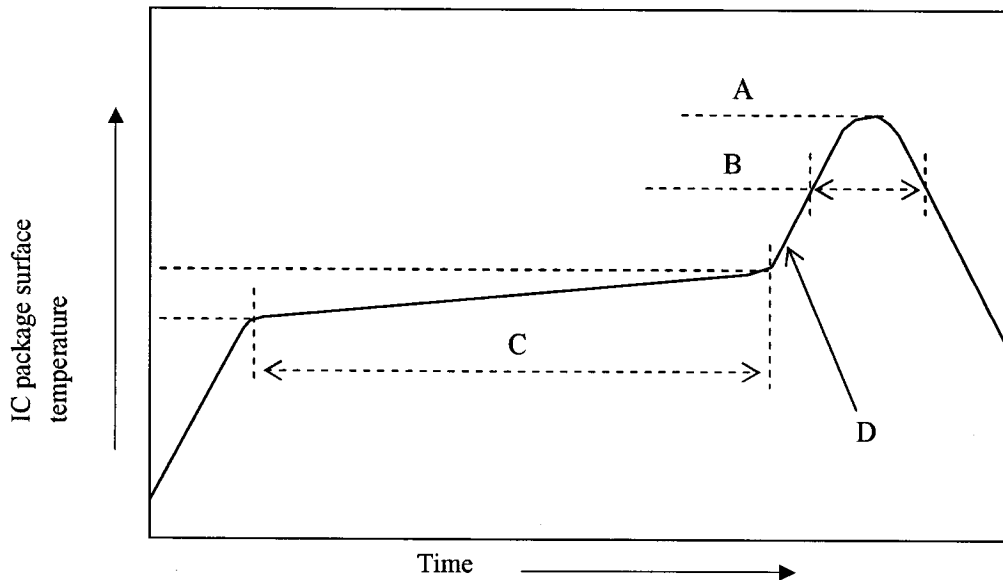

(2) Manual soldering (soldering iron) (one-time soldering only)

Soldering iron should only touch the IC's outer leads.

- Temperature and period :
350°C max. for 3 seconds / pin max.
(Soldering iron should only touch the IC's outer leads.)
- Measuring point : Soldering iron tip.

4. Condition for removal of residual flux.

- (1) Ultrasonic washing power : 25 watts / liter max.
- (2) Washing time : Total 1 minute max.
- (3) Solvent temperature : 15~40°C

5. Package outline specification.

Refer to the attached drawing.

(Plastic body dimensions do not include burr of resin.)

The contents of LEAD-FREE TYPE application of the specifications. (*2)

6. Markings.

6-1. Marking details. (The information on the package should be given as follows.)

- (1) Product name : LH28F640SPHT-PTLZ8
- (2) Company name : SHARP
- (3) Date code : (Example) YYWW XXX
 YY → Denotes the production year. (Last two digits of the year.)
 WW → Denotes the production week. (01 · 02 · ~ · 52 · 53)
 XXX → Denotes the production ref. code (1~3 digits).
- (4) "JAPAN" indicates the country of origin.

6-2. Marking layout.

The layout is shown in the attached drawing.

(However, this layout does not specify the size of the marking character and marking position.)

*2 The contents of LEAD-FREE TYPE application of the specifications.

LEAD FINISH or BALL TYPE	LEAD-FREE TYPE (Sn-Bi)
DATE CODE	They are those with an underline.
The word of " LEAD FREE" is printed on the packing label	Printed

(Note) It is those with an underline printing in a date code because of a LEAD-FREE type.

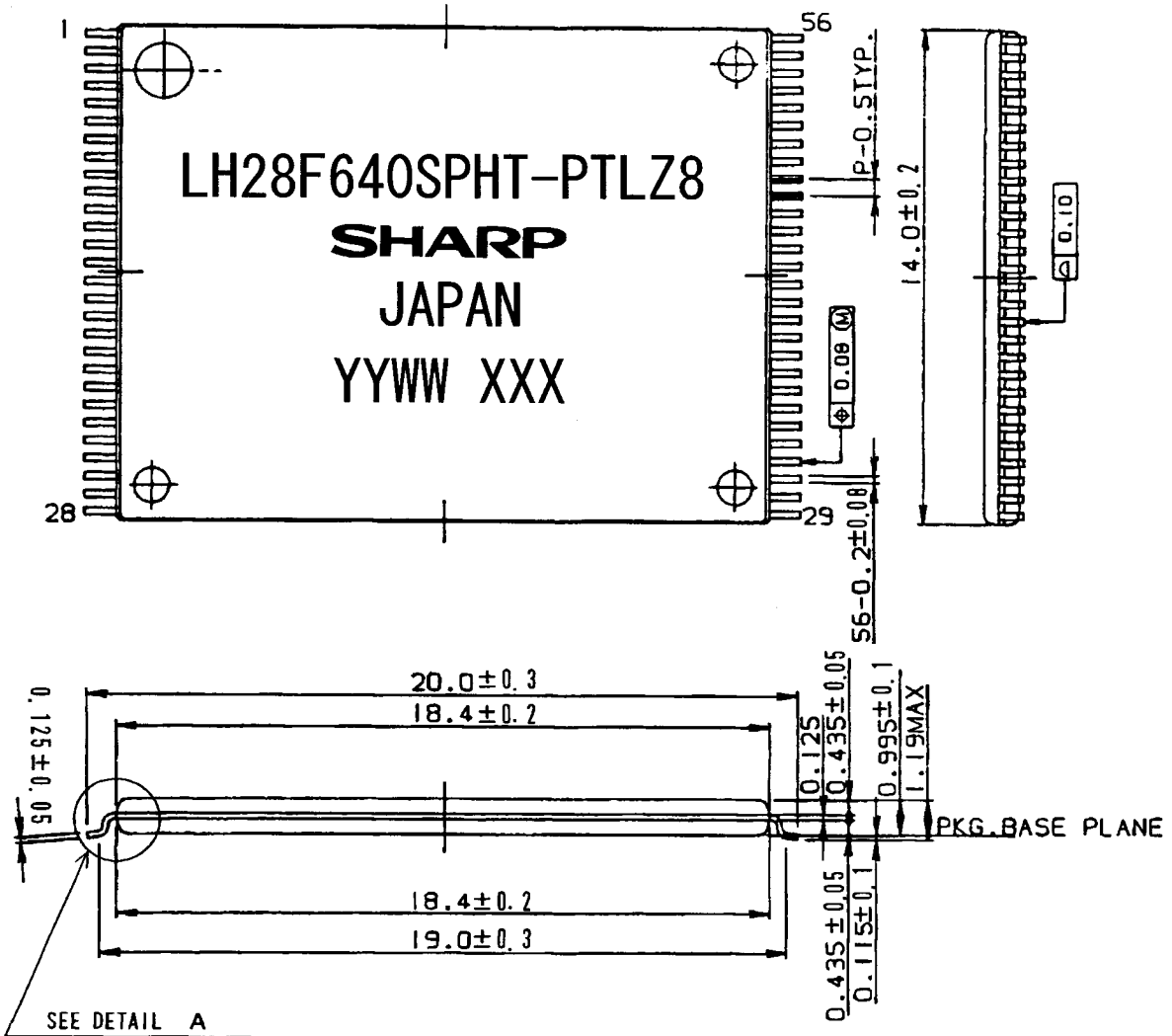

TSOP056-P-1420-AA1115

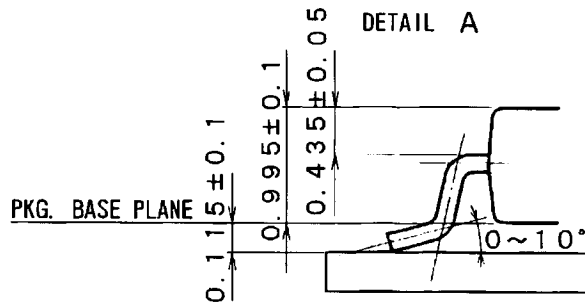

LEAD TYPE	LEAD FINISH	LEAD MATERIAL
	Sn-Bi PLATING	42Alloy
NAME	TSOP056-P-1420	
DRAWING NO.	AA1115	UNIT mm
NOTE : Plastic body dimensions do not include burr of resin.		

7. Packing Specifications (Dry packing for surface mount packages.)

7-1. Packing materials.

Material name	Material specifications	Purpose
Inner carton	Cardboard (910 devices / inner carton max.)	Packing the devices. (10 trays / inner carton)
Tray	Conductive plastic (91 devices / tray)	Securing the devices.
Upper cover tray	Conductive plastic (1 tray / inner carton)	Securing the devices.
Laminated aluminum bag	Aluminum polyethylene	Keeping the devices dry.
Desiccant	Silica gel	Keeping the devices dry.
Label	Paper	Indicates part number, quantity, and packed date.
PP band	Polypropylene (3 pcs. / inner carton)	Securing the devices.
Outer carton	Cardboard (3640 devices / outer carton max.)	Outer packing.

(Devices must be placed on the tray in the same direction.)

7-2. Outline dimension of tray.

Refer to the attached drawing.

7-3. Outline dimension of carton.

Refer to the attached drawing.

8. Precautions for use.

- (1) Opening must be done on an anti-ESD treated workbench.
All workers must also have undergone anti-ESD treatment.
- (2) The trays have undergone either conductive or anti-ESD treatment.
If another tray is used, make sure it has also undergone conductive or anti-ESD treatment.
- (3) The devices should be mounted the devices within one year of the date of delivery.

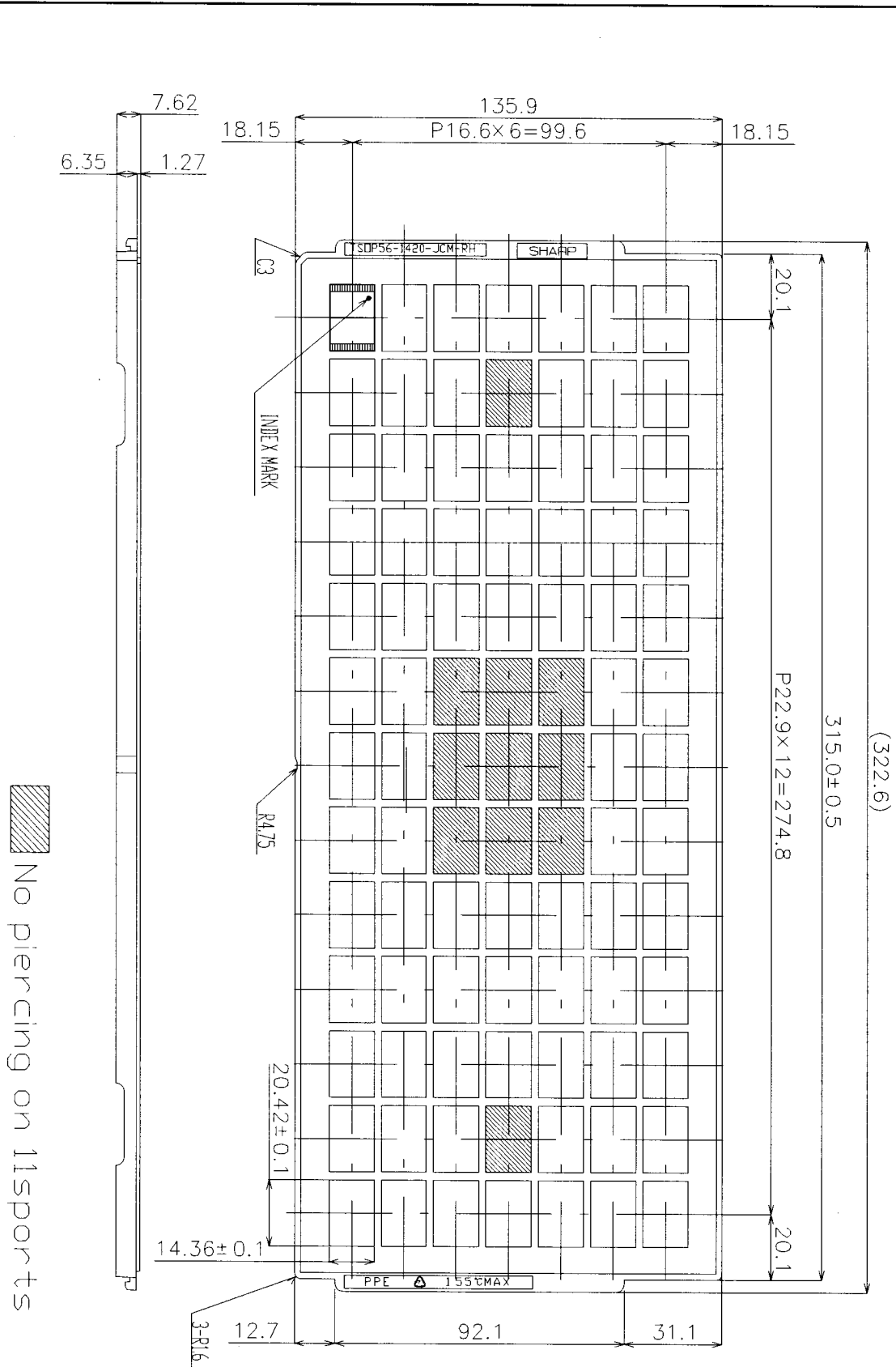

名称 NAME	TSOP56-1420-JCM-RH-N		備考 NOTE
DRAWING NO.	CV912	単位 UNIT	mm

(1) Banding device tray together.

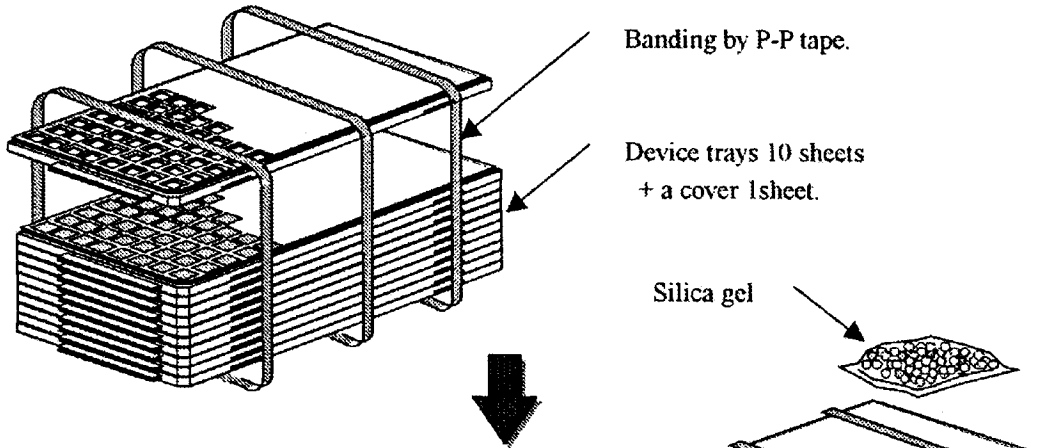

(2) Vacuum seal by Al laminating bag.

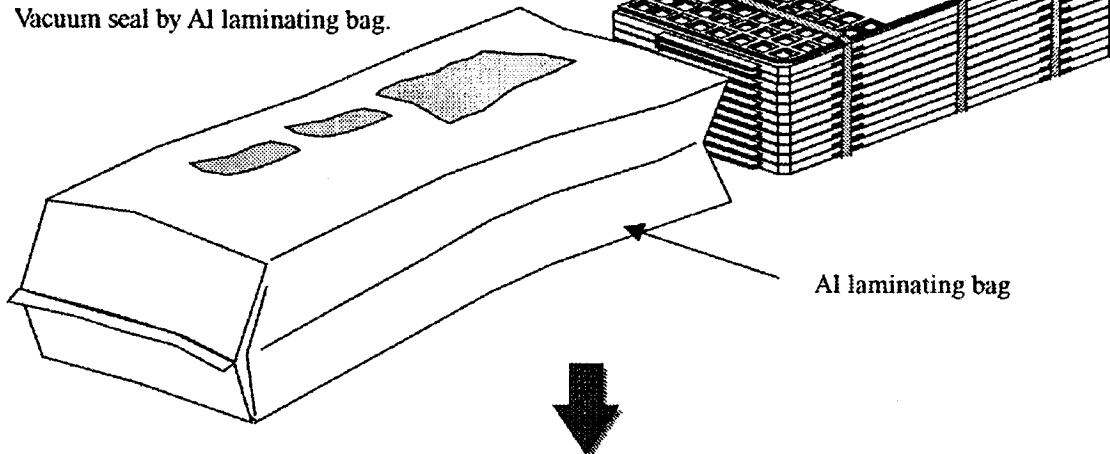

(3) Packing by Inner carton.

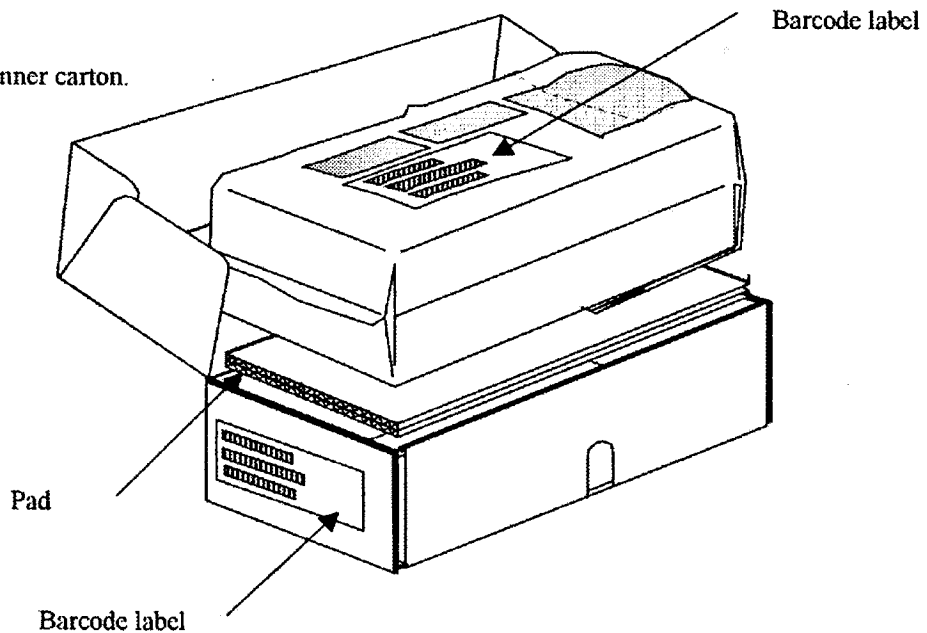

NAME	Packing specifications		
DRAWING NO.	BJ433c	UNIT	mm

NOTE There is a possibility different from this specification when the number of shipments is fractions.

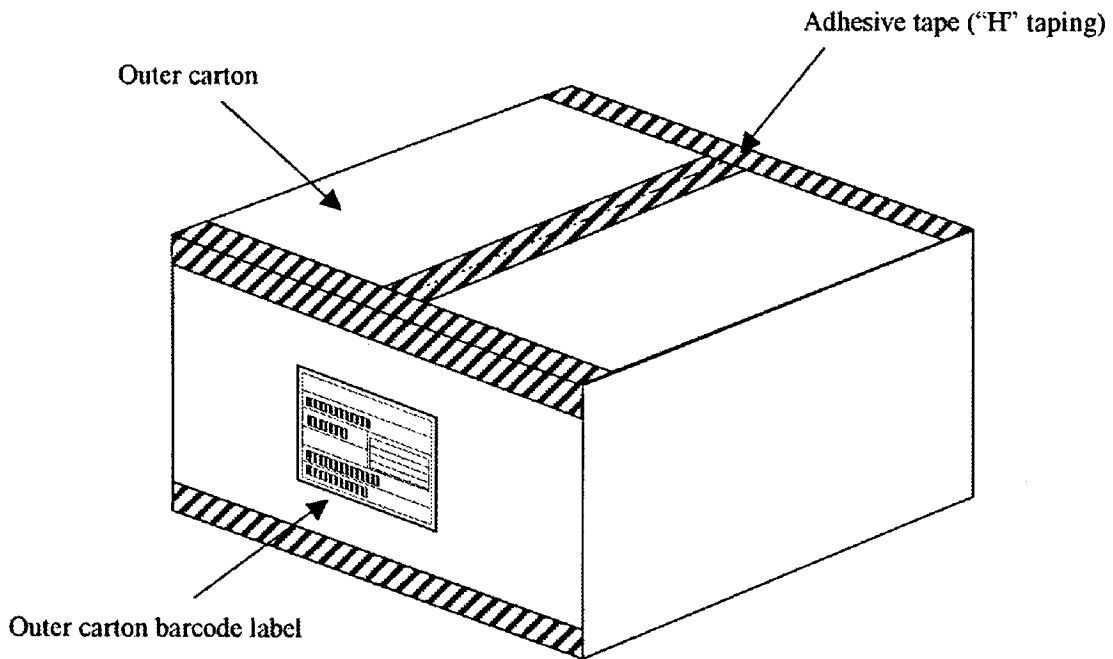
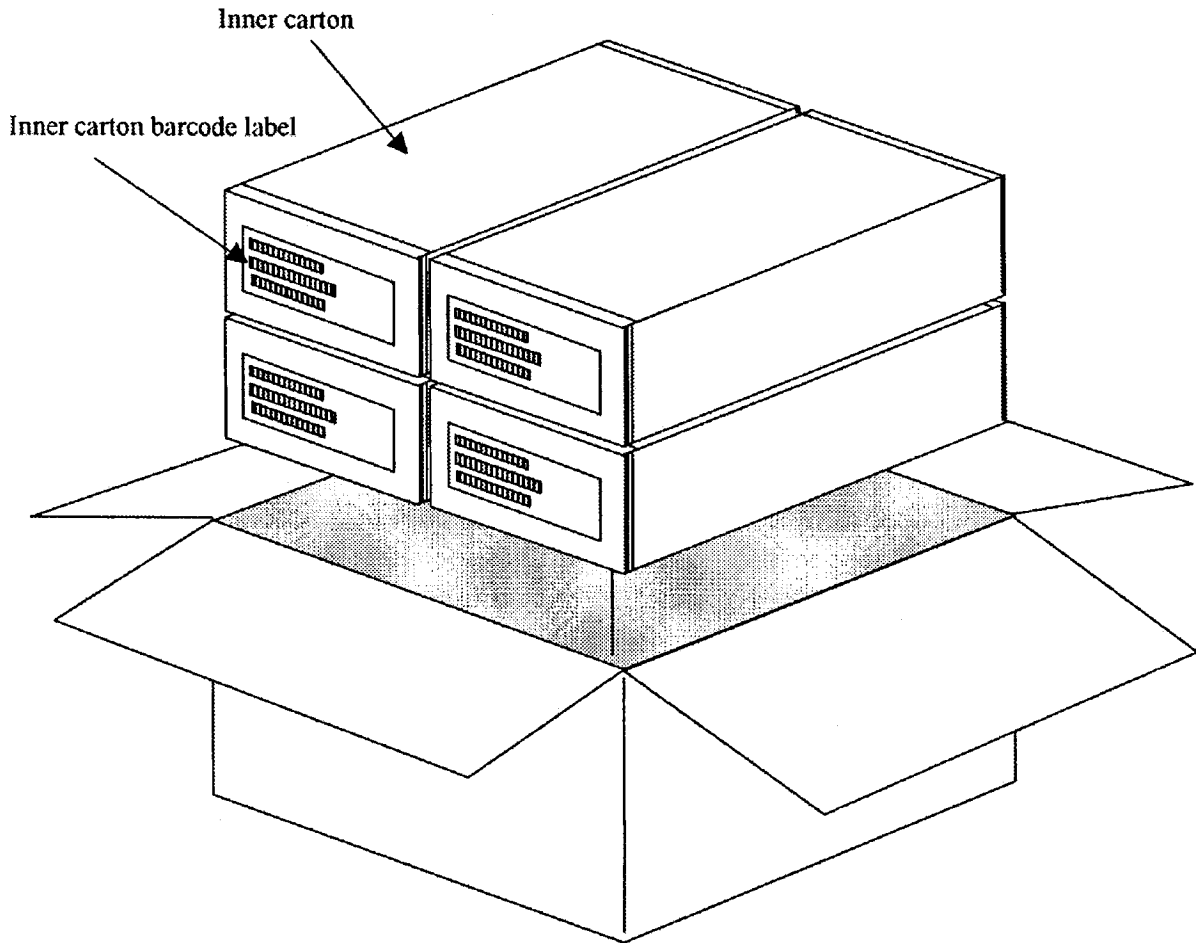

L × W × H

Inner carton - Outer dimensions : 360×150×95

Outer carton - Outer dimensions : 390×335×230

NOTE There is a possibility different from this specification when the number of shipments is fractions.

NAME	Packing specifications		
DRAWING NO.	BJ433d	UNIT	mm

(Note) The <LEAD-FREE> display shows a lead-free article.

Inner carton label

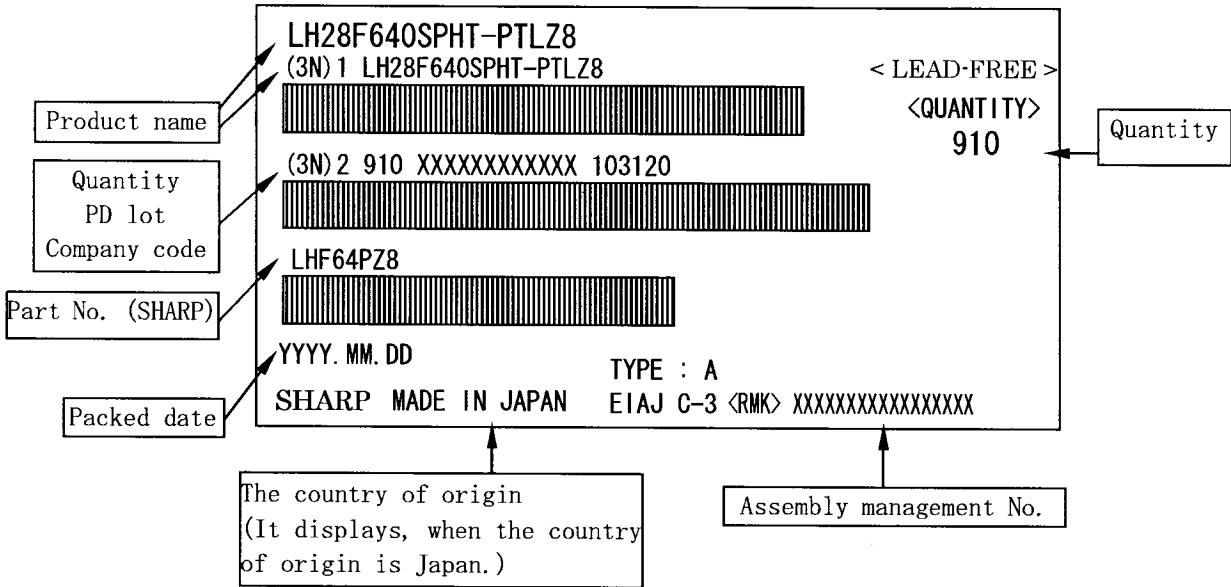

Outer carton label

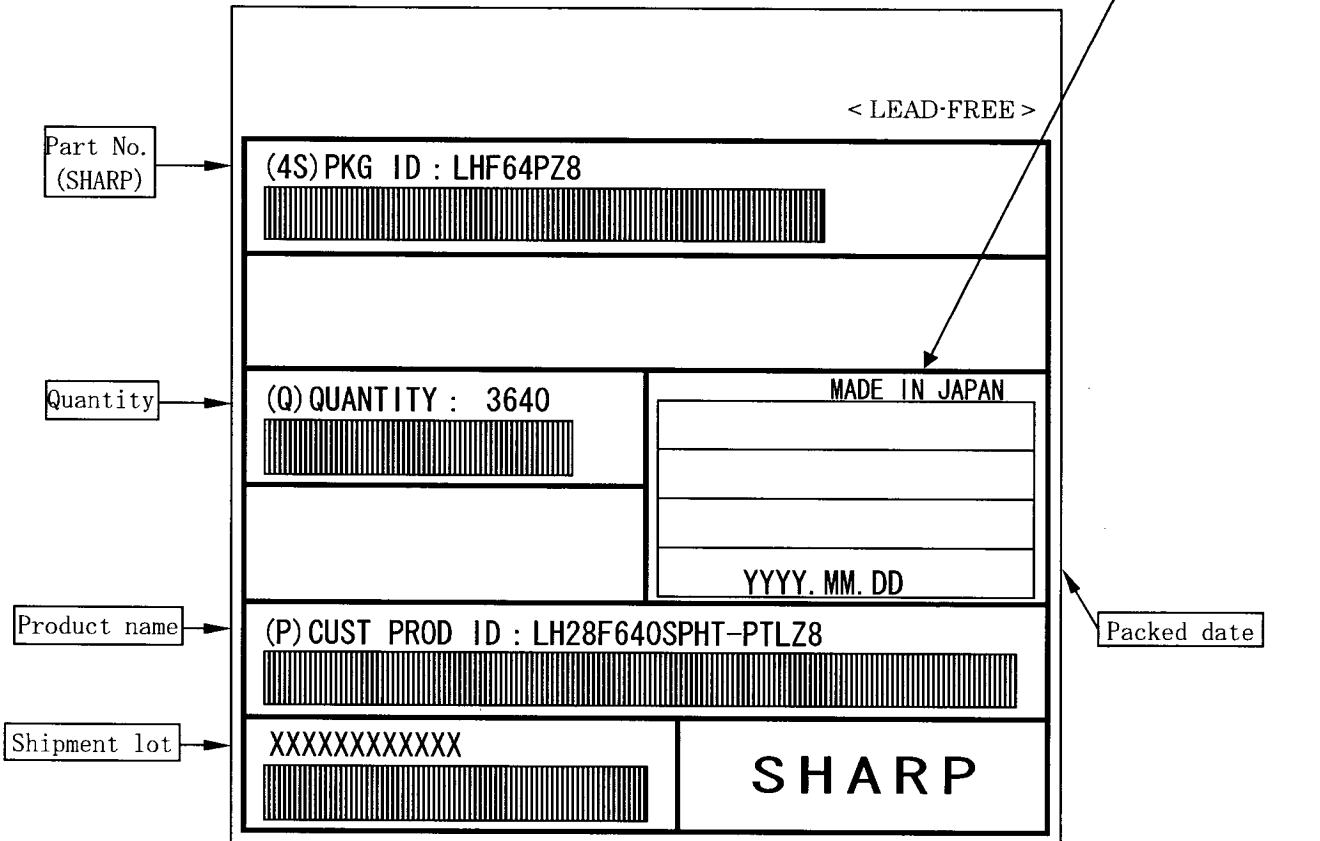

(Former) EIAJ B Standard conforming

A-1 RECOMMENDED OPERATING CONDITIONS

A-1.1 At Device Power-Up

AC timing illustrated in Figure A-1 is recommended for the supply voltages and the control signals at device power-up. If the timing in the figure is ignored, the device may not operate correctly.

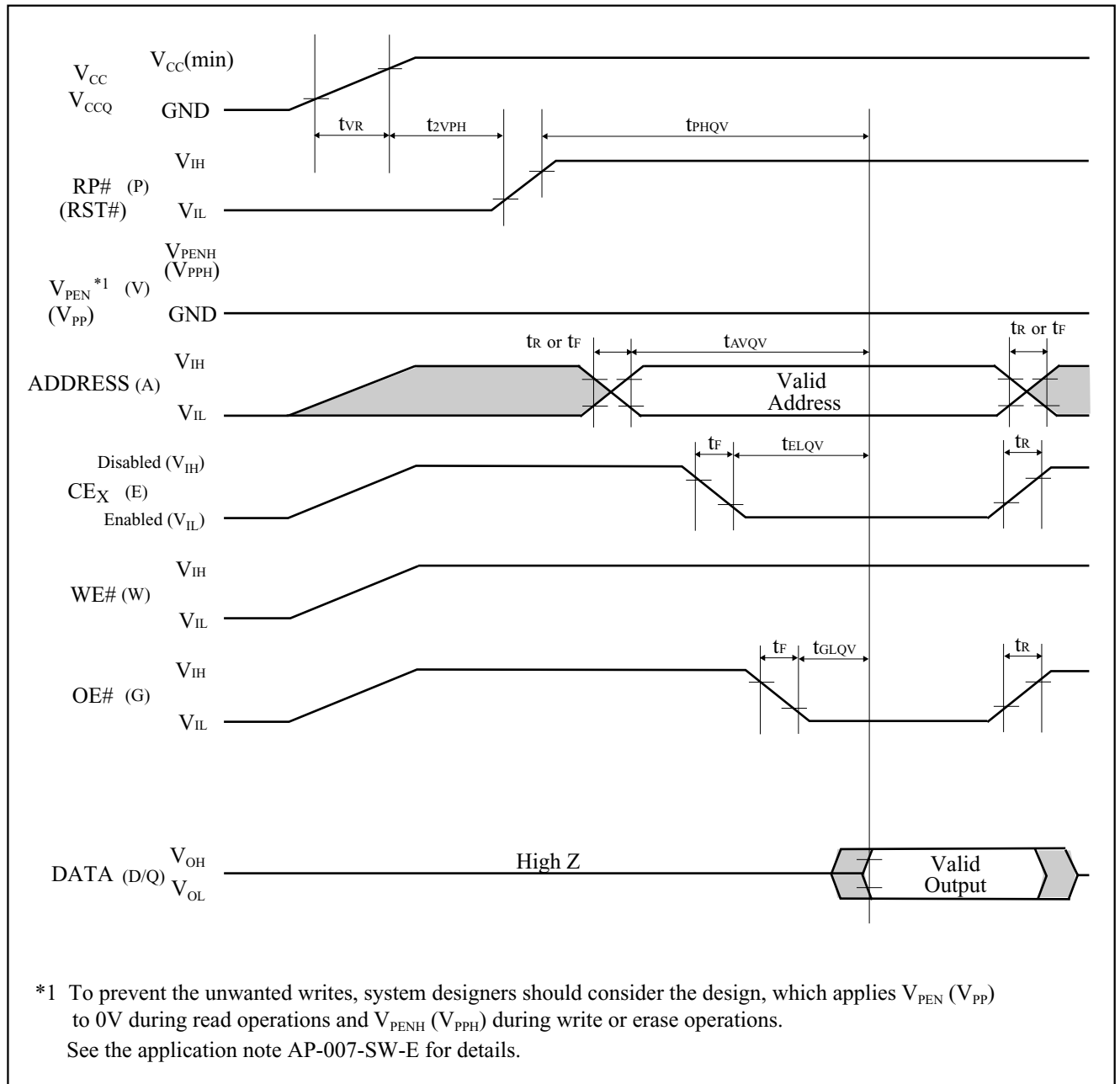

Figure A-1. AC Timing at Device Power-Up

For the AC specifications t_{VR} , t_R , t_f in the figure, refer to the next page. See the "ELECTRICAL SPECIFICATIONS" described in specifications for the supply voltage range, the operating temperature and the AC specifications not shown in the next page.

A-1.1.1 Rise and Fall Time

Symbol	Parameter	Notes	Min.	Max.	Unit
t_{VR}	V_{CC} Rise Time	1	0.5	30000	$\mu\text{s/V}$
t_R	Input Signal Rise Time	1, 2		1	$\mu\text{s/V}$
t_F	Input Signal Fall Time	1, 2		1	$\mu\text{s/V}$

NOTES:

1. Sampled, not 100% tested.
2. This specification is applied for not only the device power-up but also the normal operations.

A-1.2 Glitch Noises

Do not input the glitch noises which are below V_{IH} (Min.) or above V_{IL} (Max.) on address, data, reset, and control signals, as shown in Figure A-2 (b). The acceptable glitch noises are illustrated in Figure A-2 (a).

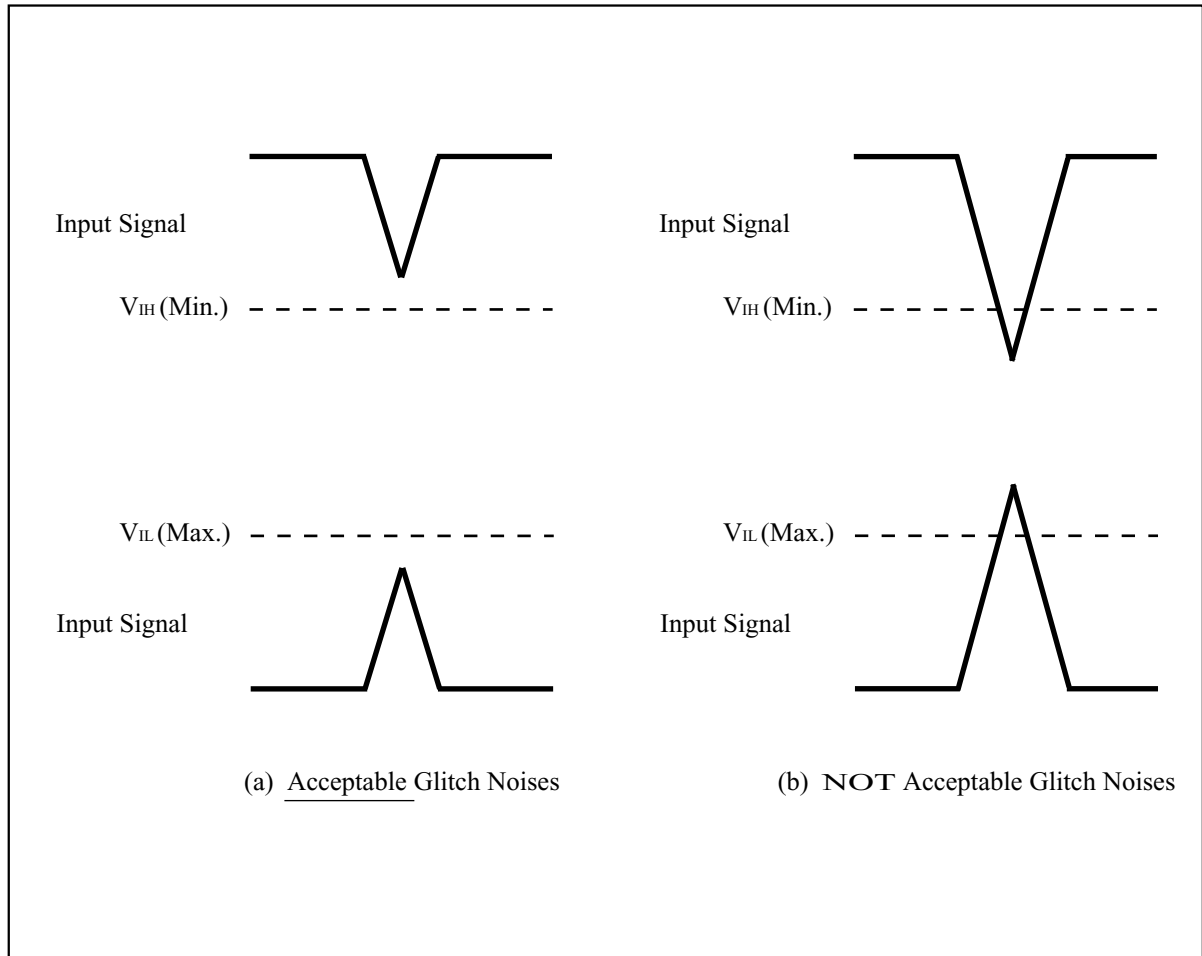

Figure A-2. Waveform for Glitch Noises

See the “DC CHARACTERISTICS” described in specifications for V_{IH} (Min.) and V_{IL} (Max.).

A-2 RELATED DOCUMENT INFORMATION⁽¹⁾

Document No.	Document Name
AP-001-SD-E	Flash Memory Family Software Drivers
AP-006-PT-E	Data Protection Method of SHARP Flash Memory
AP-007-SW-E	RP#, V_{PP} Electric Potential Switching Circuit

NOTE:

1. International customers should contact their local SHARP or distribution sales office.

SPECIFICATIONS ARE SUBJECT TO CHANGE WITHOUT NOTICE.

Suggested applications (if any) are for standard use; See Important Restrictions for limitations on special applications. See Limited Warranty for SHARP's product warranty. The Limited Warranty is in lieu, and exclusive of, all other warranties, express or implied. ALL EXPRESS AND IMPLIED WARRANTIES, INCLUDING THE WARRANTIES OF MERCHANTABILITY, FITNESS FOR USE AND FITNESS FOR A PARTICULAR PURPOSE, ARE SPECIFICALLY EXCLUDED. In no event will SHARP be liable, or in any way responsible, for any incidental or consequential economic or property damage.

SHARP®

NORTH AMERICA

SHARP Microelectronics of the Americas
5700 NW Pacific Rim Blvd.
Camas, WA 98607, U.S.A.
Phone: (1) 360-834-2500
Fax: (1) 360-834-8903
Fast Info: (1) 800-833-9437
www.sharpsma.com

EUROPE

SHARP Microelectronics Europe
Division of Sharp Electronics (Europe) GmbH
Sonninstrasse 3
20097 Hamburg, Germany
Phone: (49) 40-2376-2286
Fax: (49) 40-2376-2232
www.sharpsme.com

JAPAN

SHARP Corporation
Electronic Components & Devices
22-22 Nagaike-cho, Abeno-Ku
Osaka 545-8522, Japan
Phone: (81) 6-6621-1221
Fax: (81) 6117-725300/6117-725301
www.sharp-world.com

TAIWAN

SHARP Electronic Components
(Taiwan) Corporation
8F-A, No. 16, Sec. 4, Nanking E. Rd.
Taipei, Taiwan, Republic of China
Phone: (886) 2-2577-7341
Fax: (886) 2-2577-7326/2-2577-7328

SINGAPORE

SHARP Electronics (Singapore) PTE., Ltd.
438A, Alexandra Road, #05-01/02
Alexandra Technopark,
Singapore 119967
Phone: (65) 271-3566
Fax: (65) 271-3855

KOREA

SHARP Electronic Components
(Korea) Corporation
RM 501 Geosung B/D, 541
Dohwa-dong, Mapo-ku
Seoul 121-701, Korea
Phone: (82) 2-711-5813 ~ 8
Fax: (82) 2-711-5819

CHINA

SHARP Microelectronics of China
(Shanghai) Co., Ltd.
28 Xin Jin Qiao Road King Tower 16F
Pudong Shanghai, 201206 P.R. China
Phone: (86) 21-5854-7710/21-5834-6056
Fax: (86) 21-5854-4340/21-5834-6057

Head Office:

No. 360, Bashen Road,
Xin Development Bldg. 22
Waigaoqiao Free Trade Zone Shanghai
200131 P.R. China
Email: smc@china.global.sharp.co.jp

HONG KONG

SHARP-ROXY (Hong Kong) Ltd.
3rd Business Division,
17/F, Admiralty Centre, Tower 1
18 Harcourt Road, Hong Kong
Phone: (852) 28229311
Fax: (852) 28660779
www.sharp.com.hk

Shenzhen Representative Office:

Room 13B1, Tower C,
Electronics Science & Technology Building
Shen Nan Zhong Road
Shenzhen, P.R. China
Phone: (86) 755-3273731
Fax: (86) 755-3273735