

THIS COPY IS PROVIDED ON A RESTRICTED BASIS AND IS NOT TO BE USED IN ANY WAY DETRIMENTAL TO THE INTERESTS OF PANDUIT CORP.

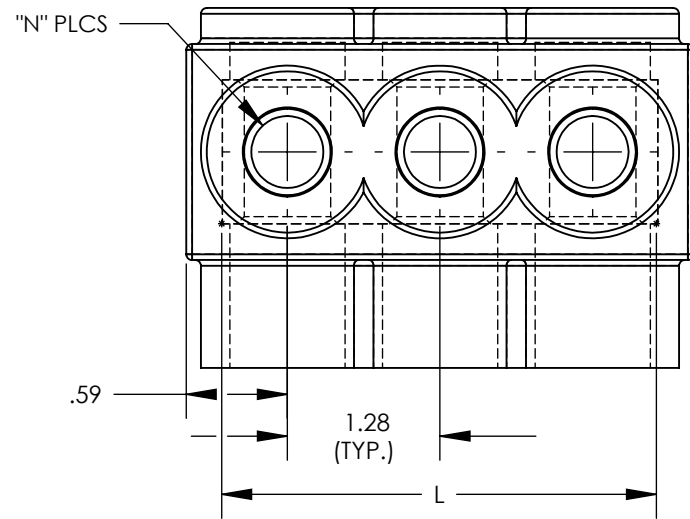

THREE PORT CONNECTOR BLOCK SHOWN WITH PLASTIC CLOSURE PLUGS REMOVED. SEE TABLE FOR DIMENSIONS OF PARTS WITH ADDITIONAL PORTS

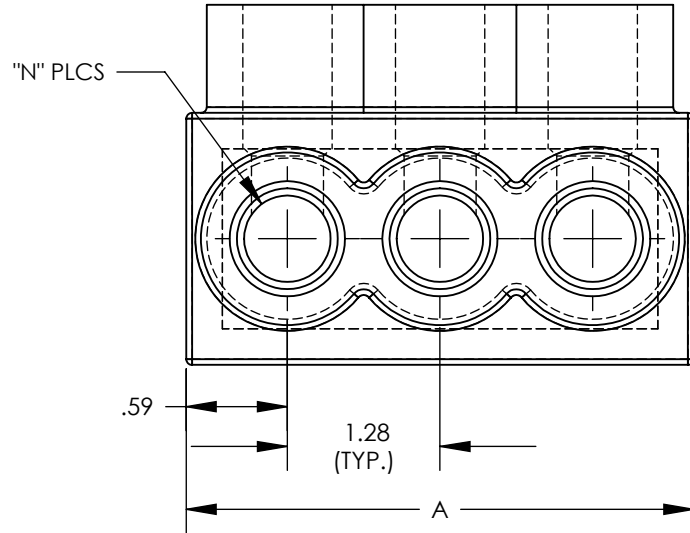

CLAMPLING SCREW ACCESS PORT (TYP.)

CONDUCTOR PORT (TYP.)

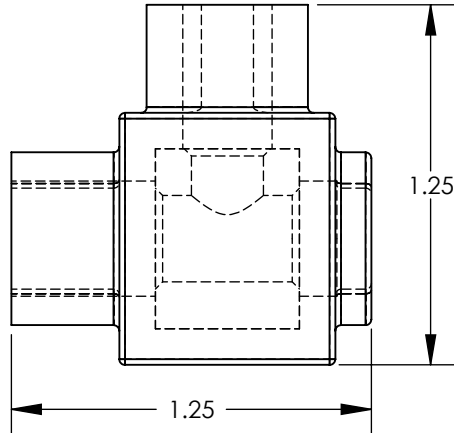
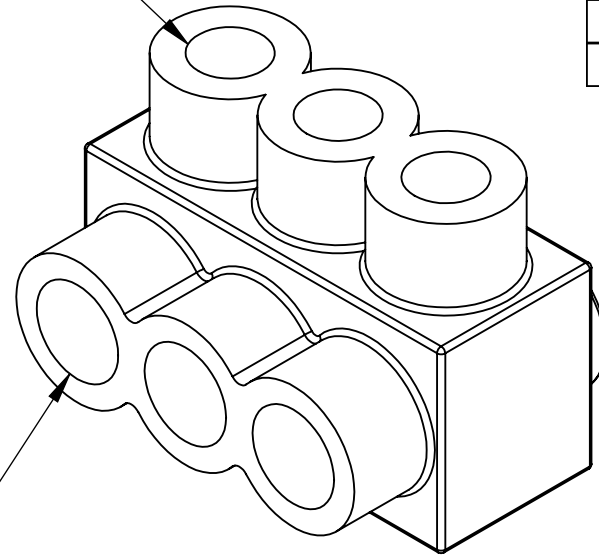

PANDUIT FINISHED GOODS P/N	CONDUCTOR RANGE	HEX KEY	SCREW QTY.	CAP (SCREW PORT) QTY.	CAP (WIRE PORT) QTY.	A	L	N	TIGHTENING TORQUE
PCSB600-2S-4Y	600 kcmil - # 6 STR	3/8	2	2	2	2.72	2.469	2	375 in/lb
PCSB600-3S-3Y		3/8	3	3	3	4.00	3.750	3	
PCSB600-4S-2Y		3/8	4	4	4	5.28	5.031	4	
PCSB600-5S-2Y		3/8	5	5	5	6.56	6.312	5	
PCSB600-6S-2Y		3/8	6	6	6	7.84	7.593	6	
PCSB600-8S-2Y		3/8	8	8	8	10.41	10.155	8	
PCSB600-10S-1Y		3/8	10	10	20	12.97	12.717	10	
PCSB600-12S-1Y		3/8	12	12	24	15.53	15.279	12	
PCSB600-14S-1Y		3/8	14	14	28	18.09	17.841	14	



NOTES:

- UL486A-UL486B LISTED, DUAL RATED CU9AL FOR ALUMINUM OR COPPER CONDUCTORS. MEETS OR EXCEEDS ANSI C119.4
- SEE TABLE FOR WIRE RANGE.
- STRIP LENGTH: 1.06 +.06/-0
- FOR TIGHTENING TORQUE SEE TABLE
- VOLTAGE RATING: 600 V. MAX. BUILDING WIRE, 1000 V. MAX. IN SIGNS & FIXTURES.
- TEMPERATURE RATING: 90 °C (CU9AL).
- CONNECTOR BLOCK BODY ARE MADE FROM ALUMINUM. CONDUCTOR PORTS IN CONNECTOR BLOCK ARE PREFILLED WITH AN OXIDE-INHIBITING COMPOUND.
- CONNECTOR TO INCLUDE TIN PLATED ALUMINUM CLAMPING SCREWS FOR EACH CONDUCTOR PORT.
- INSULATION MATERIAL IS CLEAR PVC.
- CLAMPING SCREW ACCESS PORTS AND ALL WIRE ENTRY PORTS ARE PROVIDED WITH REMOVABLE PLASTIC CLOSURE PLUGS.
- ALL DIMENSIONS SHOWN ARE NOMINAL.
- ONLY ONE CONDUCTOR PER PORT ALLOWED.
- PACKAGE QTY: -12 = 12 PCS.
-6 = 6 PCS.
-4 = 4 PCS.
-3 = 3 PCS.
-2 = 2 PCS.
- THIS PART IS RoHS COMPLIANT

REV	DATE	BY	CHK	APR	DESCRIPTION	ECN
05	2/13	JHNU	JHNU	RGB	REVISED TITLE BLOCK	N41531BB-C41531

TITLE		MULTI-TAP INSULATED CONNECTORS PCSB600 SERIES SINGLE SIDED CUSTOMER DRAWING	
ITEM REVISION NAME	N41531BB-C41531/05		
DATASET FILE NAME	C41531/05.SLDDRW		
UNLESS OTHERWISE SPECIFIED, DIMENSIONAL TOLERANCES ARE: IN [mm]		MATERIAL	
.X ±	.XXX ±	SEE NOTES	
.XX ± .02	ANGLES ±	DRAWING NUMBER	
THIRD ANGLE PROJECTION		C41531_05	
DRAWN BY	DATE	CHK	SCALE
MS	8/99	RLS	NONE
SHEET 1 OF 1			SIZE
			B