



American Opto Plus LED Corp.

L233LYC-TR

2.8 x 0.8 x 1.2 mm Yellow SMD LED

PACKAGE OUTLINES

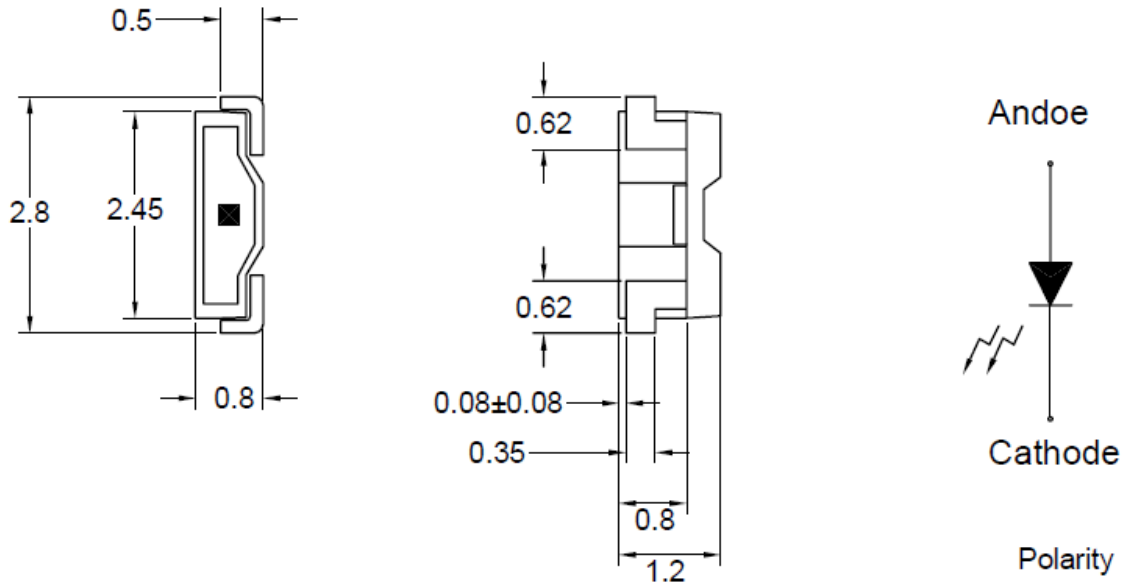

RECOMMENDED PAD LAYOUT

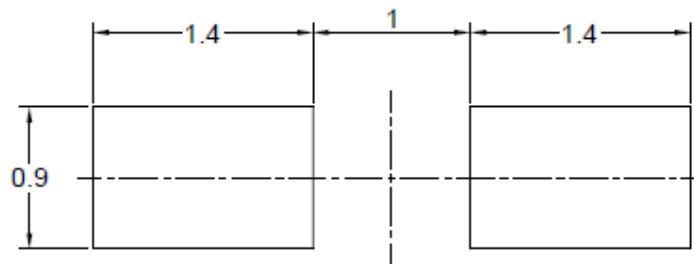

NOTES:

1. All dimensions are in millimeters tolerance is ± 0.1 mm unless otherwise noted; Angle ± 0.5

Part Number	Material	Lens Color	
		Emitted	Lens
L233LYC-TR	AlGaInP	Yellow	Water Clear



American Opto Plus LED Corp.

L233LYC-TR

2.8 x 0.8 x 1.2 mm Yellow SMD LED

ABSOLUTE MAXIMUM RATINGS

(Ta=25°C)

Parameter	Symbol	Ratings	Unit
Power Dissipation	Pd	78	mW
Peak Forward Current (Duty 1/10@10KHz)	I _{fp}	60	mA
Forward Current	I _f	30	mA
Reverse Current @ 5V	I _r	10	µA
Electrostatic Discharge	ESD	2000	V
Operating temperature range	T _{opr}	-40~+85	°C
Storage temperature range	T _{stg}	-40~+90	°C
Soldering Temperature	T _{sol}	Max 260°C for 5 sec	

OPTICAL-ELECTRICAL CHARACTERISTICS

(Ta=25°C)

Parameter	Symbol	Test Condition	Min	Typ	Max	Unit
Luminous Intensity	I _v	I _F =20mA	590	800	--	mcd
Dominant Wavelength	λ _D		585	590	592	nm
Spectral Line Half-Width	Δλ		--	36	--	nm
Forward Voltage	V _f		1.9	--	2.5	V
Viewing angle	2θ ½		--	115	--	Deg

- *Note: 1. The forward voltage data did not include ±0.1V testing tolerance.
2. The luminous intensity data did not include ±15% testing tolerance.



American Opto Plus LED Corp.

L233LYC-TR

2.8 x 0.8 x 1.2 mm Yellow SMD LED

LUNIOUS INTENSITY CLASSIFICATION

BIN CODE	Iv (mcd) @ 20mA	
	Min.	Max
U4	590	620
U5	620	650
U6	650	680
U7	680	710
U8	710	740
U9	740	770
U10	770	800
U11	800	830
U12	830	860
U13	860	890
U14	890	920
U15	920	930
U16	930	960
U17	960	990
U18	990	1020



American Opto Plus LED Corp.

L233LYC-TR

2.8 x 0.8 x 1.2 mm Yellow SMD LED

DOMINANT WAVELENGTH CLASSIFICATION

BIN CODE	λ_D (nm) @ 20mA	
	Min.	Max
15	585	587
16	587	589
17	589	592

FORWARD VOLTAGE CLASSIFICATION

BIN CODE	Vf (v) @ 20mA	
	Min.	Max
1	1.9	2.0
2	2.0	2.1
3	2.1	2.2
4	2.2	2.3
5	2.3	2.4
6	2.4	2.5



American Opto Plus LED Corp.

L233LYC-TR

2.8 x 0.8 x 1.2 mm Yellow SMD LED

TYPICAL ELECTRO-OPTICAL CHARACTERISTIC CURVES

Fig.1 Forward current vs. Forward Voltage

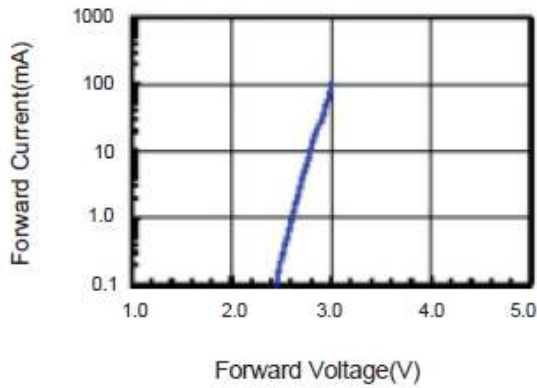

Fig.2 Relative Intensity vs. Forward Current

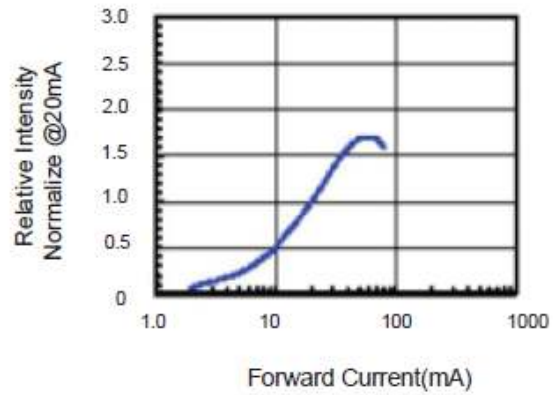

Fig.3 Forward Voltage vs. Temperature

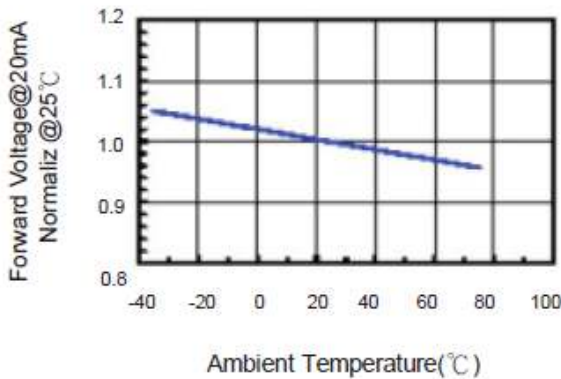

Fig.4 Relative Intensity vs. Temperature

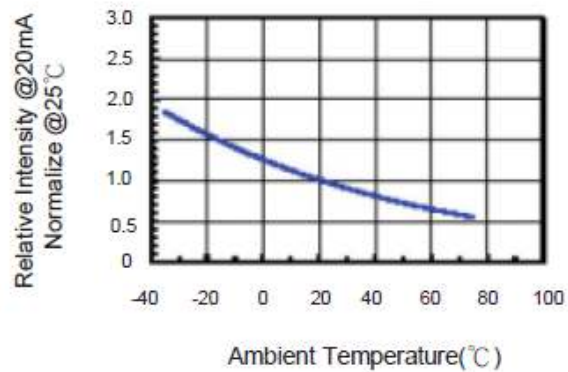

Fig.5 Relative Intensity vs. Wavelength

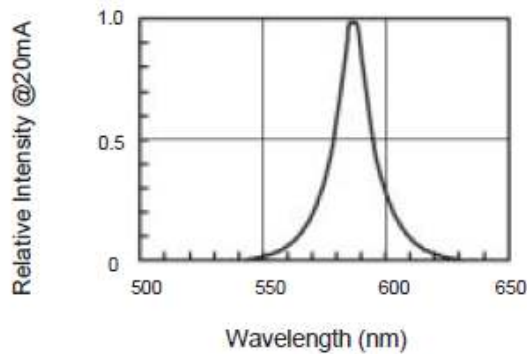
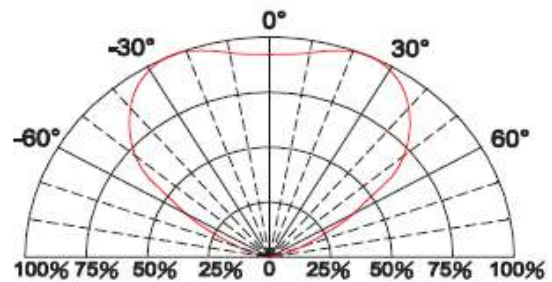

Fig.6 Directive Radiation





American Opto Plus LED Corp.

L233LYC-TR

2.8 x 0.8 x 1.2 mm Yellow SMD LED

CARRIER TAPE DIMENSION

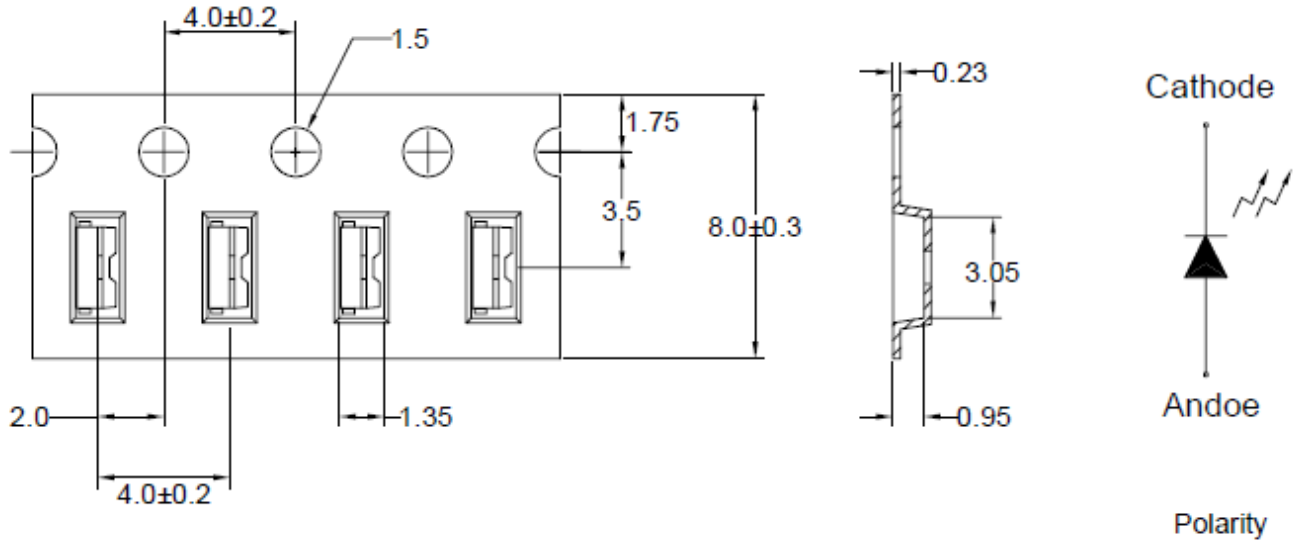

Note: The tolerances unless mentioned are ± 0.1 mm, Angle ± 0.5 ; Unit=mm

REEL DIMENSIONS

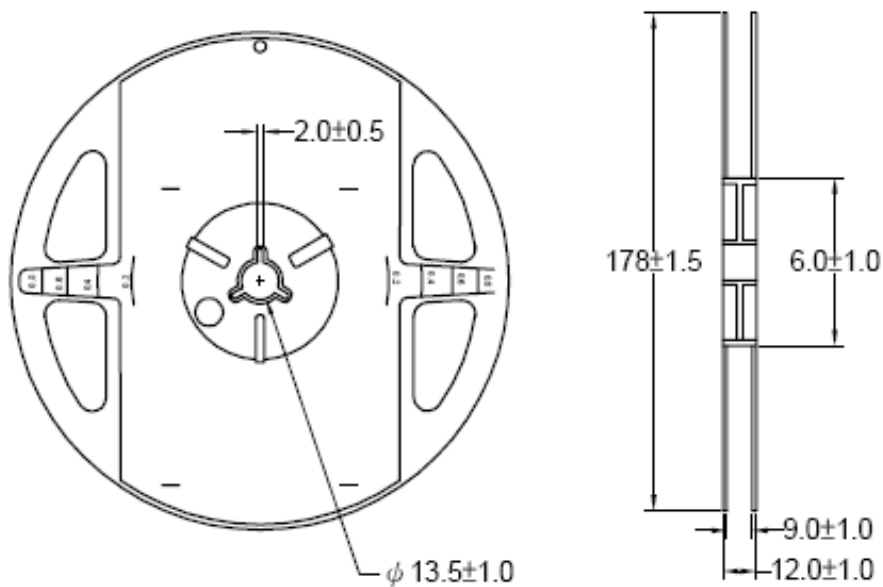

Notes:

1. 3000 pieces per reel.



American Opto Plus LED Corp.

L233LYC-TR

2.8 x 0.8 x 1.2 mm Yellow SMD LED

RECOMMENDED SOLDERING CONDITIONS

Soldering Iron:

Basic spec is ≤ 5 seconds when 260°C .

Power dissipation of iron should be smaller than 25W, and temperature should be controllable. Surface temperature of the device should be under 280°C for 3 seconds.

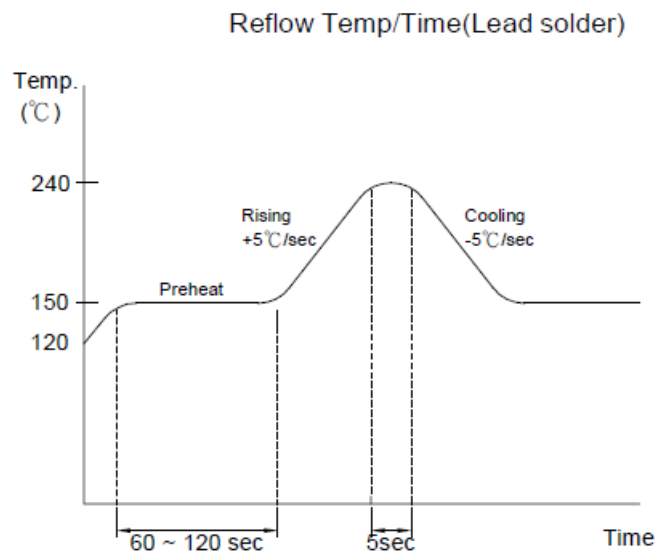
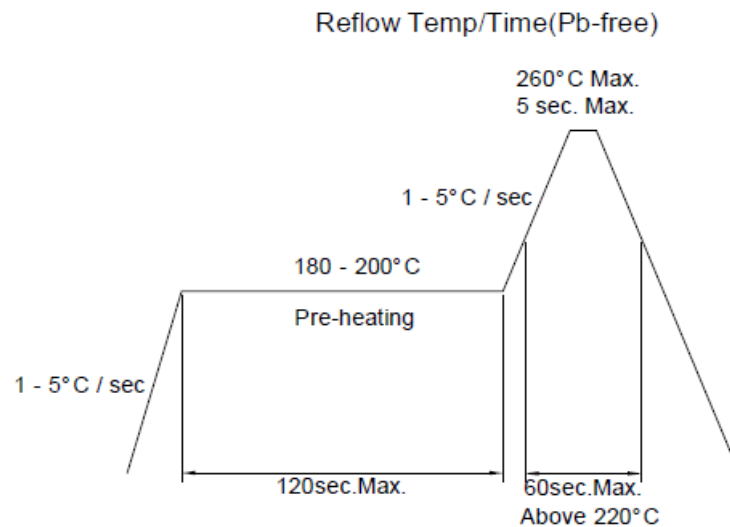

Notes:

1. Reflow soldering should not be done more than two times.
2. When soldering, do not put stress on the LEDs during heating.
3. After soldering, do not warp the circuit board.



American Opto Plus LED Corp.

L233LYC-TR

2.8 x 0.8 x 1.2 mm Yellow SMD LED

PRECAUTIONS FOR USE

Storage Time:

1. The operation of temperatures and RH are: 5°C~35°C, RH60%.
2. Once the package is opened, the products should be used within a week. Otherwise, they should be kept in a damp proof box with desiccating agent. Considering the tape life, we suggest our customers to use our products within a year (from production date).
3. If opened more than one week in an atmosphere 5°C~35°C, RH60%, they should be treated at 60°C±5°C for 15hrs.

Drive Method:

LED is a current operated device, and therefore, require some kind of current limiting incorporated into the driver circuit. This current limiting typically takes the form of a current limiting resistor placed in a series with the LED.

Consider worst case voltage variations that could occur across the current limiting resistor. The forward current should not be allowed to change by more than 40% of its desired value.

Circuit model A

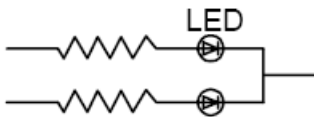

Circuit model B

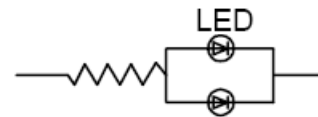

(A) Recommended circuit.

(B) The difference of brightness between LED could be found due to the VF-IF characteristics of LED.

Cleaning:

Use alcohol-based cleaning solvents such as isopropyl alcohol to clean the LED.

ESD (Electrostatic Discharge):

Static Electricity or power surge will damage the LED. Use of a conductive wrist band or anti-electrostatic glove is recommended when handling these LEDs. All devices and machinery must be properly grounded.



American Opto Plus LED Corp.

L233LYC-TR

2.8 x 0.8 x 1.2 mm Yellow SMD LED

RELIABILITY TEST:

(1) Test items and results

Classification	Test Item	Test Condition	Sample Size
Endurance Test	Operating Life Test	1.Ta=Under Room Temperature As Per Data Sheet Maximum Rating. 2.If=20mA 3.t=1000 hrs	22
	High Temperature Storage Test	1.Ta=105°C±5°C 2.t=500 hrs	22
	Low Temperature Storage Test	1.Ta=-40°C±5°C 2.t=1000 hrs	22
	High Temperature High Humidity Storage Test	1.IR-Reflow In-Board, 2 Times 2.Ta=85°C±5°C 3.RH=90%~95% 4.t=500hrs±2hrs	22
Environmental Test	Thermal Shock Test	1.IR-Reflow In-Board, 2 times 2.Ta=105°C±5°C & -40°C±5°C (30min) (30min) 3.total 100 cycles	22
	Reflow Soldering Test	1.T.Sol=260°C±5°C 2.Dwell Time= 10Max.	22
	Temperature Cycling	1.105°C ~ 25°C ~ -40°C 30mins 15mins 30mins 2.100 Cycles	22

(2) Criteria for judging the damage

Item	Symbol	Test Conditions	Criteria for Judgement	
			Min.	Max.
Forward Voltage	Vf	If=20mA	--	U.S.L. x 1.2
Reverse Current	Ir	Vr=5V	--	U.S.L. x 2.0
Luminous Intensity	Iv	If=20mA	L.S.L. x 0.5	--

Note:

1. U.S.L.: Upper Standard Level.
2. L.S.L.: Lower Standard Level.

Version 1.0 Date: 5-13-2013 Specifications are subject to change without notice.

American Opto Plus LED Corp. 1206 E. Lexington Ave., Pomona CA 91766 Tel: 909-465-0080 Fax: 909-465-0130 www.aopled.com