

SF1091A

**211 MHz
SAW Filter**

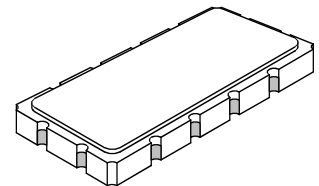

SM13365-12

- **Designed for GSM BTS Transmitter Applications**
- **Low Insertion Loss**
- **Excellent Size-to-Performance Ratio**
- **Hermetic 13.3 X 6.5 mm Surface-Mount Case**
- **Unbalanced Input and Output**
- **Complies with Directive 2002/95/EC (RoHS)**
- **Tape and Reel Standard per ANSI/EIA-481**
- **Moisture Sensitivity Level: 1**
- **AEC-Q200 Qualified**

Absolute Maximum Ratings

Rating	Value	Units
Maximum Incident Power in Passband	+10	dBm
Max. DC voltage between any 2 terminals	30	VDC
Storage Temperature Range	-40 to +85	°C
Suitable for lead-free soldering - Max Soldering Profile	260°C for 30 s	

Electrical Specification

Characteristic	Sym	Notes	Min	Typ	Max	Units
Nominal Center Frequency	f_c			211.000		MHz
Passband	Insertion Loss at f_c 3 dB Passband	IL		7	8.0	dB
		BW_3	± 450	± 500		kHz
		GDV		200	250	$n_{sp,p}$
Rejection	$f_c - 2.0$ to $f_c - 1.05$ and $f_c + 1.05$ to $f_c + 2.0$ MHz		10	21		dB
		$f_c - 80$ to $f_c - 2.0$ and $f_c + 2.0$ to $f_c + 80$ MHz	30	33		
		$n \times f_c$ over 291 to 2000 MHz	40	60		
Operating Temperature Range	T_A		-10		+85	°C
Frequency Temperature Coefficient	FTC			0.32		ppm/°C ²

Impedance Matching to 50 Ω unbalanced	External L-C
Case Style	SM13365-12 13.3 x 6.5 mm Nominal Footprint
Lid Symbolization (YY = year, WW = week, S = shift, ## = sequence code)	RFM, SF1091A, YYWWS##

 **CAUTION: Electrostatic Sensitive Device. Observe precautions for handling.**

NOTES:

1. The design, manufacturing process, and specifications of this device are subject to change.
2. US or International patents may apply.
3. RoHS compliant from the first date of manufacture.

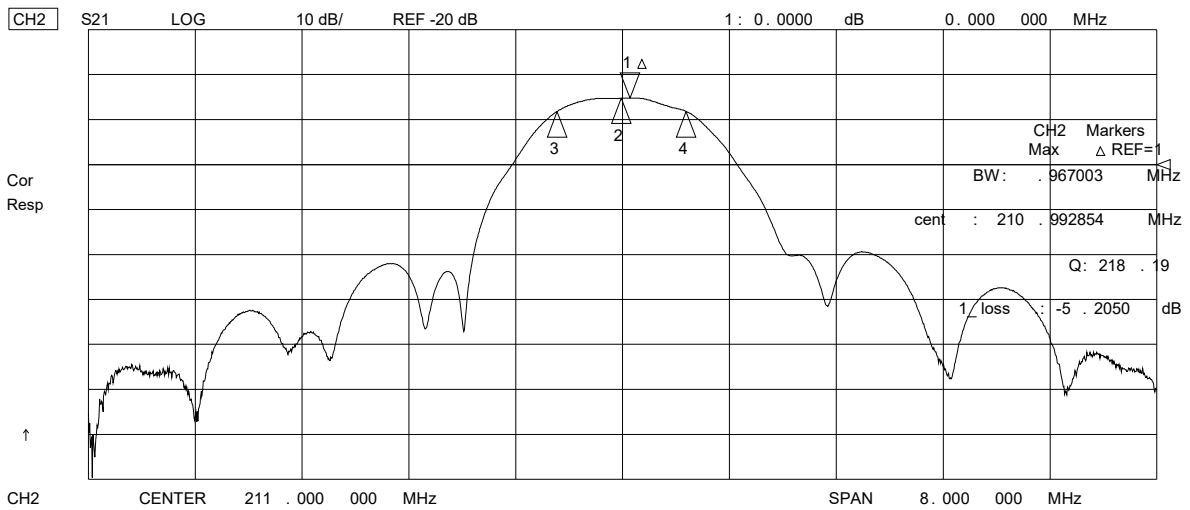
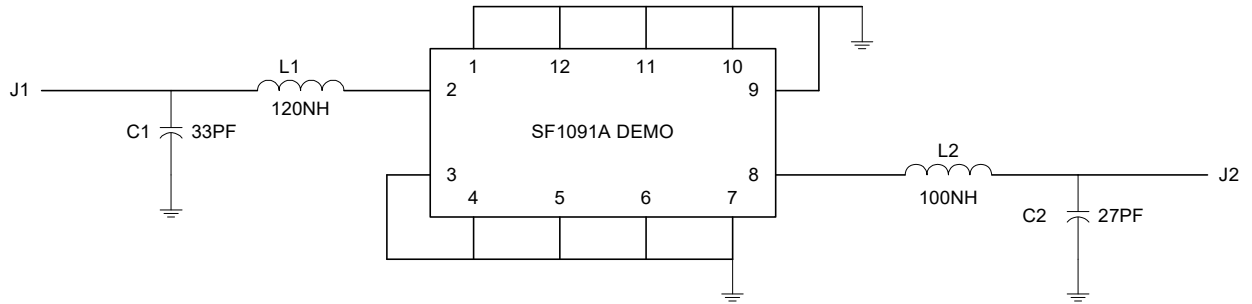

SM13365-12 Case

12-Terminal Ceramic Surface-Mount Case 13.3 x 6.5 mm Nominal Footprint

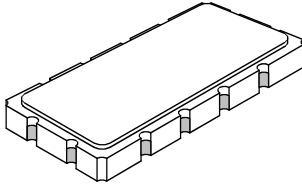

Case Dimensions						
Dimension	mm			Inches		
	Min	Nom	Max	Min	Nom	Max
A	13.08	13.31	13.60	0.515	0.524	0.535
B	6.27	6.50	6.80	0.247	0.256	0.268
C		1.91	2.00		0.075	0.079
D		1.50			0.059	
E		0.79			0.031	
H		1.0			0.039	
P		2.54			0.100	

Materials	
Solder Pad Termination	Au plating 30 - 60 ulnches (76.2-152 uM) over 80-200 ulnches (203-508 uM) Ni.
Lid	Fe-Ni-Co Alloy Electroless Nickel Plate (8-11% Phosphorus) 100-200 ulnches Thick
Body	Al ₂ O ₃ Ceramic

Electrical Connections		
Connection		Terminals
Port 1	Input or Return	2
	Return or Input	3
Port 2	Output or Return	8
	Return or Output	9
Ground		All others
Single Ended Operation		Return is ground
Differential Operation		Return is hot

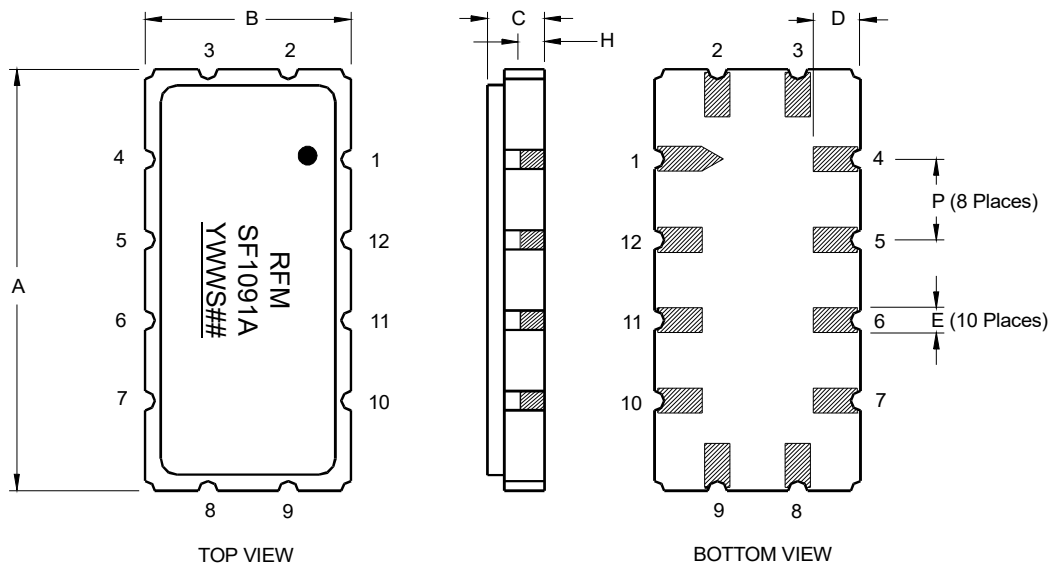

COMPONENT ORIENTATION and DIMENSIONS

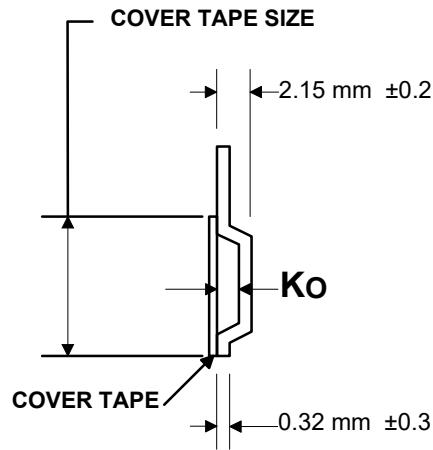
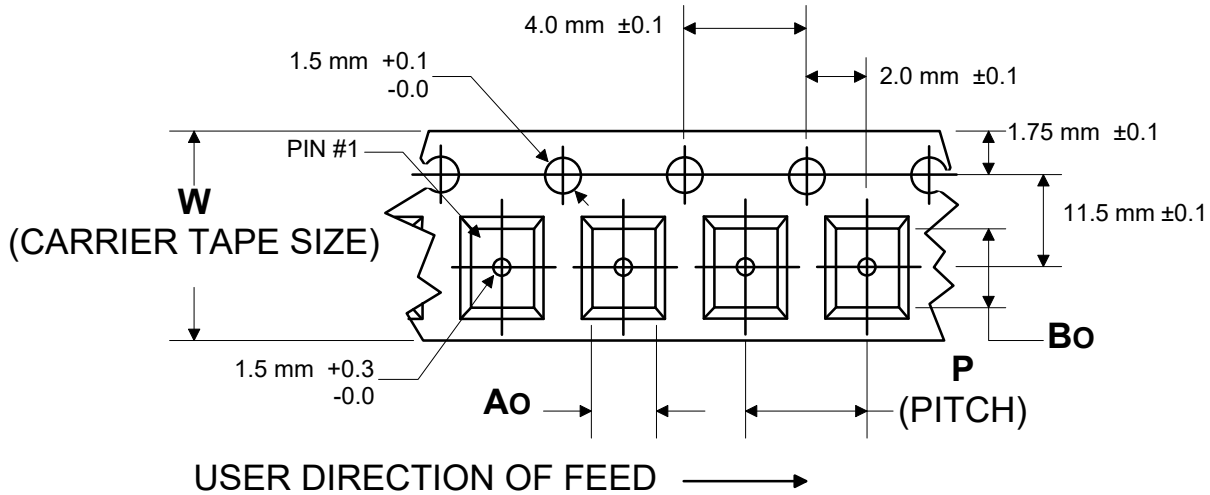

Carrier Tape Dimensions		
Ao	7.0 mm	± 0.1
Bo	13.8 mm	± 0.1
Ko	2.2 mm	± 0.1
Pitch	12.0 mm	± 0.1
W	24.0 mm	± 0.3

Recommended Reflow Profile

1. Preheating shall be fixed at 150~180°C for 60~90 seconds.
2. Ascending time to preheating temperature 150°C shall be 30 seconds min.
3. Heating shall be fixed at 220°C for 50~80 seconds and at 260°C+0/-5°C peak (10 seconds).
4. Time: 5 times maximum.

