

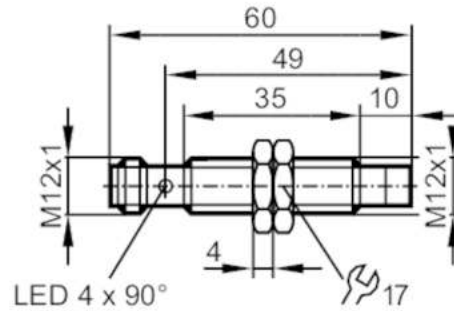

## Inductive sensor

IFK3010-BPKG/K1/US-104



### Product characteristics

Electrical design	PNP
Output function	normally open
Sensing range [mm]	10
Housing	threaded type
Dimensions [mm]	M12 x 1 / L = 60

### Application

Special feature	Gold-plated contacts; Increased sensing range; Correction factor K = 1; Magnetic-field immune
Application	Suitable for industrial, mobile, cooling and lubricating applications; Industrial applications / factory automation
Magnetic-field immune	yes
Max. magnetic field immunity [mT]	300

### Electrical data

Operating voltage [V]	10...30 DC
Current consumption [mA]	< 20
Protection class	III
Reverse polarity protection	yes

### Outputs

Electrical design	PNP
Output function	normally open
Max. voltage drop switching output DC [V]	2.5
Permanent current rating of switching output DC [mA]	100
Switching frequency DC [Hz]	2000
Short-circuit protection	yes
Overload protection	yes

# IFS286



## Inductive sensor

IFK3010-BPKG/K1/US-104

Detection zone		
Sensing range	[mm]	10
Real sensing range Sr	[mm]	10 ± 10 %
Operating distance	[mm]	0...8.1
Increased sensing range		yes
Accuracy / deviations		
Correction factor		steel: 1 / stainless steel: 1 / brass: 1 / aluminium: 1 / copper: 1
Hysteresis	[% of Sr]	3...15
Switch point drift	[% of Sr]	-10...10
Correction factor K = 1		yes
Operating conditions		
Ambient temperature	[°C]	-40...85
Protection		IP 65; IP 66; IP 67; IP 68; IP 69K
Tests / approvals		
EMC	EN 61000-4-2 ESD	4 kV CD / 8 kV AD
	EN 61000-4-3 HF radiated	10 V/m
	EN 61000-4-4 Burst	2 kV
	EN 61000-4-6 HF conducted	10 V
Vibration resistance	EN 55011	class B
	EN 60068-2-6 Fc	20 g (10...3000 Hz) / 50 sweep cycles, 1 octave per minute, in 3 axes
	EN 60068-2-27 Ea	100 g 11 ms half-sine; 3 shocks each in every direction of the 3 coordinate axes
Shock resistance	EN 60068-2-27	40 g 6 ms; 4000 shocks each in every direction of the 3 coordinate axes
Continuous shock resistance	EN 60068-2-14 Na	TA = -40 °C; TB = 85 °C; t1 = 30 min; t2 = < 10 s; 50 cycles
Fast temperature change	EN 60068-2-52 Kb	severity level 5 (4 test cycles)
Salt spray test		
MTTF	[years]	474
Embedded software included		yes
UL approval	Ta	-25...70 °C
	Enclosure type	Type 1
	power supply	Limited Voltage/Current
	UL Approval no.	A005
	File number UL	E174191
Mechanical data		
Weight	[g]	26.3
Housing		threaded type
Mounting		non-flush mountable
Dimensions	[mm]	M12 x 1 / L = 60
Thread designation		M12 x 1
Materials		brass white bronze coated; sensing face: LCP white; LED window: PEI; lock nuts: brass white bronze coated
Displays / operating elements		
Display	switching status	4 x LED, yellow

# IFS286



## Inductive sensor

IFK3010-BPKG/K1/US-104

Accessories	
Items supplied	lock nuts: 2
Remarks	
Pack quantity	1 pcs.
Electrical connection - plug	
Connector: 1 x M12; coding: A; Contacts: gold-plated	

