

REVISIONS				
P	LTR	DESCRIPTION	DATE	APVD
	G5	REVISED PER ECN-22-150900	27APR2022	RK CSD

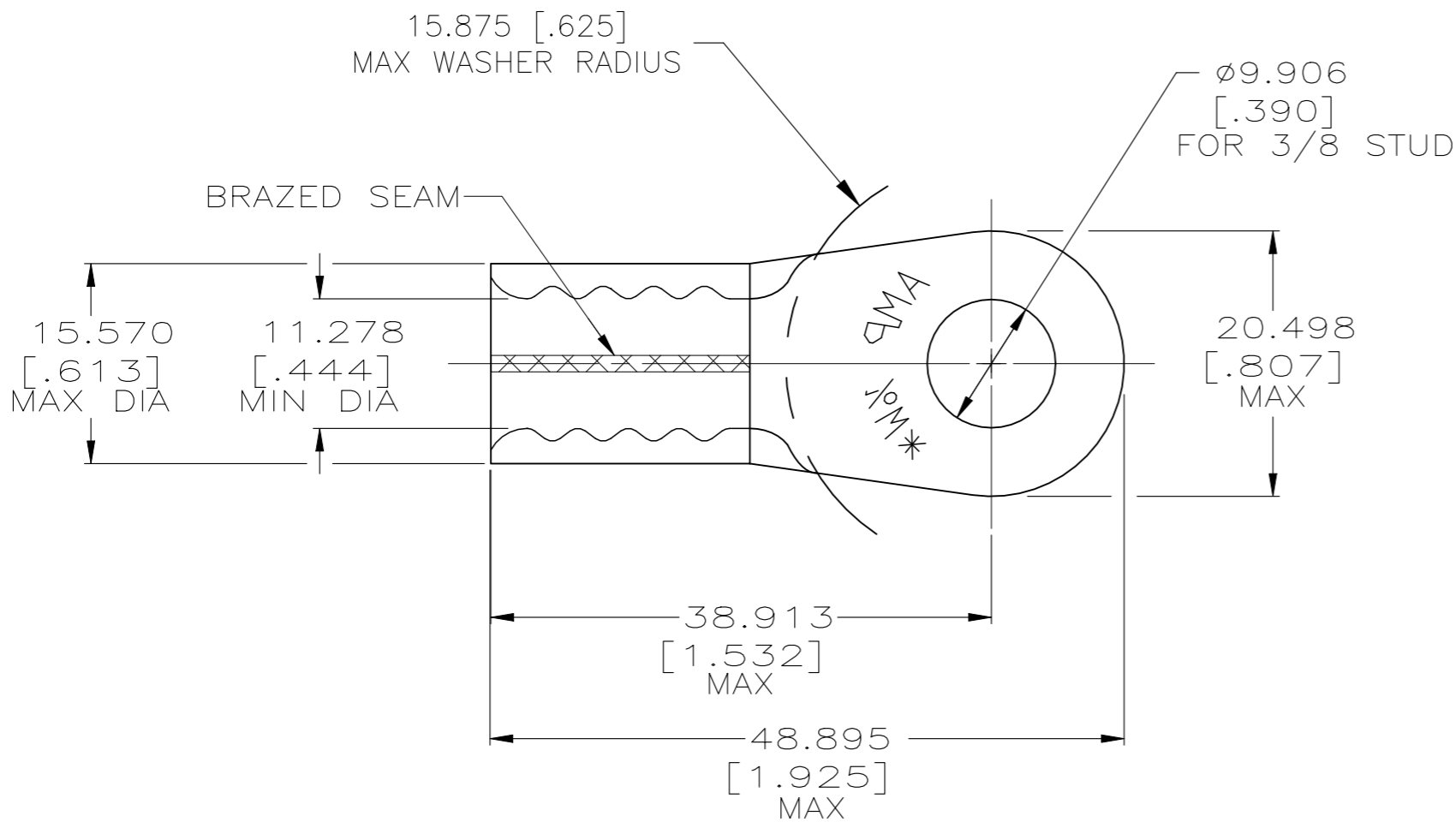

<b>AMP</b> WIRE RANGE	E13288 Listed
1/0 AWG SOLID OR STRANDED	1/0 AWG STRANDED

LR7189 Certified
1/0 AWG SOLID OR STRANDED

- 1 TIN PL 0.00254[.000100] MIN EXT. THK PER ASTM B-545
- 2 NOTE DELETED

QTY.	PACKAGE TYPE	FINISH	MATERIAL	PART NUMBER
50	LOOSE PIECE	CLEANED	COPPER ASTM B-152	2-321868-2
50	LOOSE PIECE		1.778±0.076[.070±.003] ANNEALED	321868

MAX RECOMMENDED OPERATING TEMPERATURE: 170°[338°F]C	THIS DRAWING IS A CONTROLLED DOCUMENT.		DWN DK SCHRUM 8/30/91	TE Connectivity		
	VOLTAGE RATING: N/A	DIMENSIONS: mm[INCHES]	TOLERANCES UNLESS OTHERWISE SPECIFIED:			
CIRCULAR MIL AREA: 42.4-60.6mm² [83,700-119,500] SOILD OR STRANDED	MATERIAL SEE TABLE	FINISH SEE TABLE	PRODUCT SPEC UL 486 A-B	TERMINAL, RING TONGUE, SOLISTRAND WIRE SIZE 50.0mm2 [1/0] AWG		
			APPLICATION SPEC -	SIZE A3	CAGE CODE 00779	DRAWING NO C-321868
			WEIGHT -	RESTRICTED TO -		SCALE 2:1
			CUSTOMER DRAWING	SHEET 1 OF 1		REV G5