

VICOR CONFIDENTIAL
 THIS DOCUMENT AND THE DATA DISCLOSED HEREIN OR
 HEREIN IS NOT TO BE REPRODUCED, USED OR
 DISCLOSED IN ANY MANNER OR IN PART TO ANYONE WITHOUT
 THE PERMISSION OF VICOR CORP.

REV.	DESCRIPTION	DATE	APPROVED
1	RELEASED PER E120943 GCK	10/22/12	REJH
2	REVISED PER E130143 GCK	02/01/13	REJH

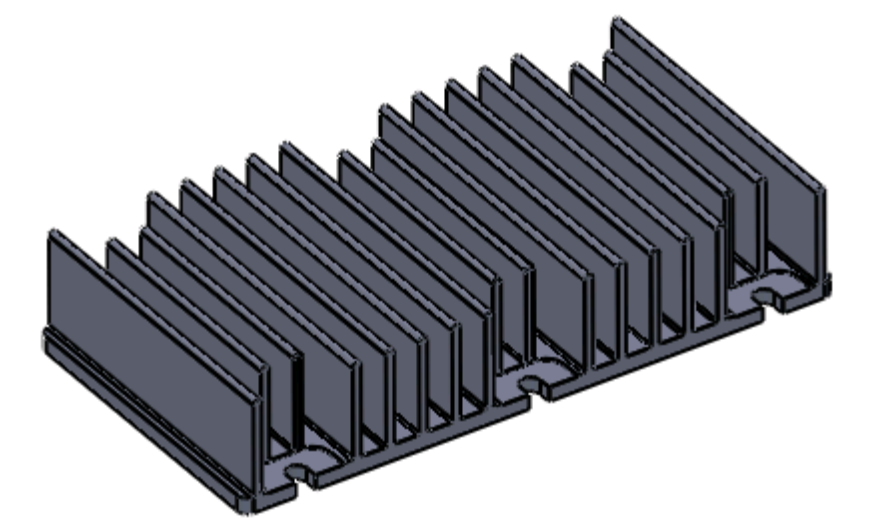
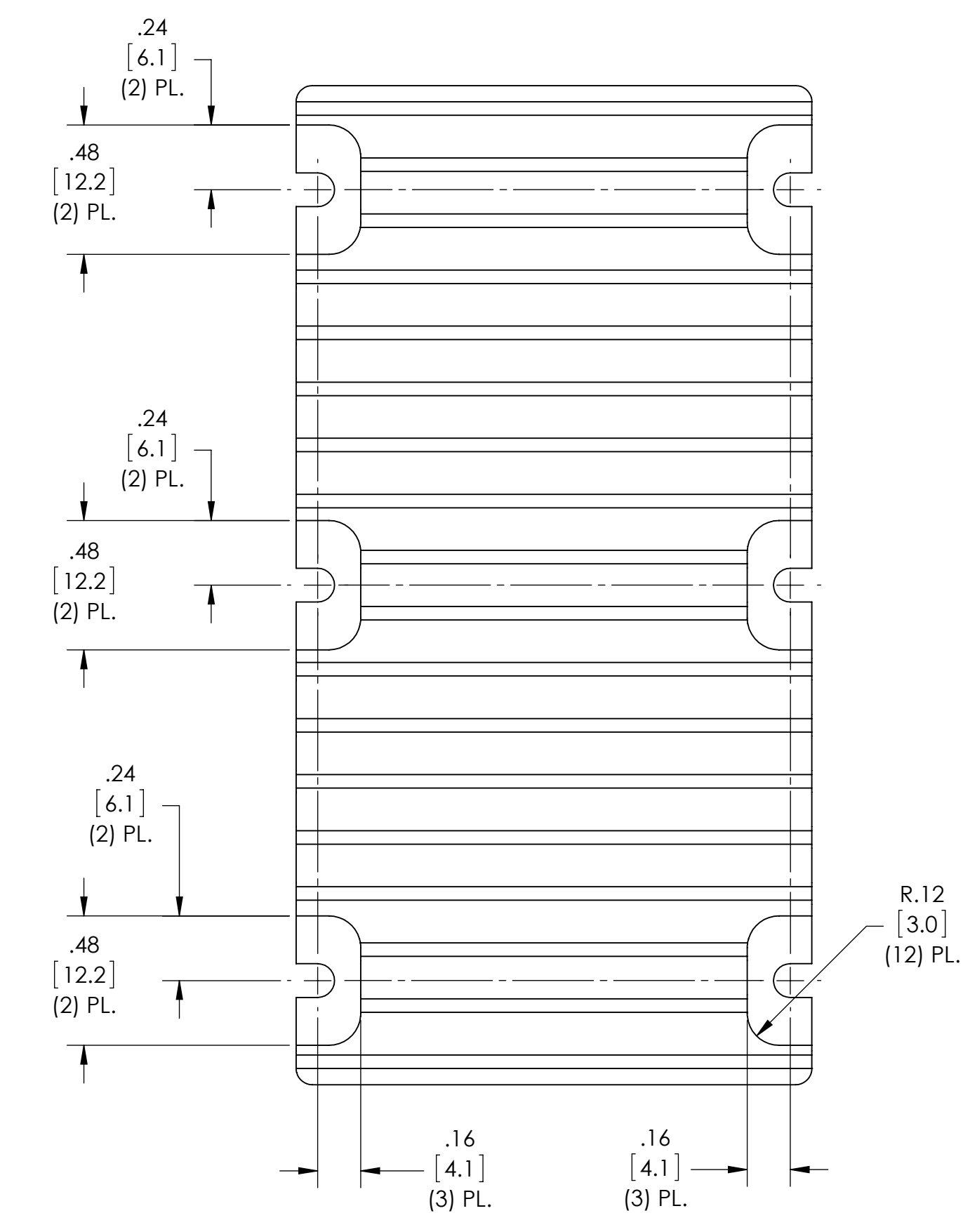
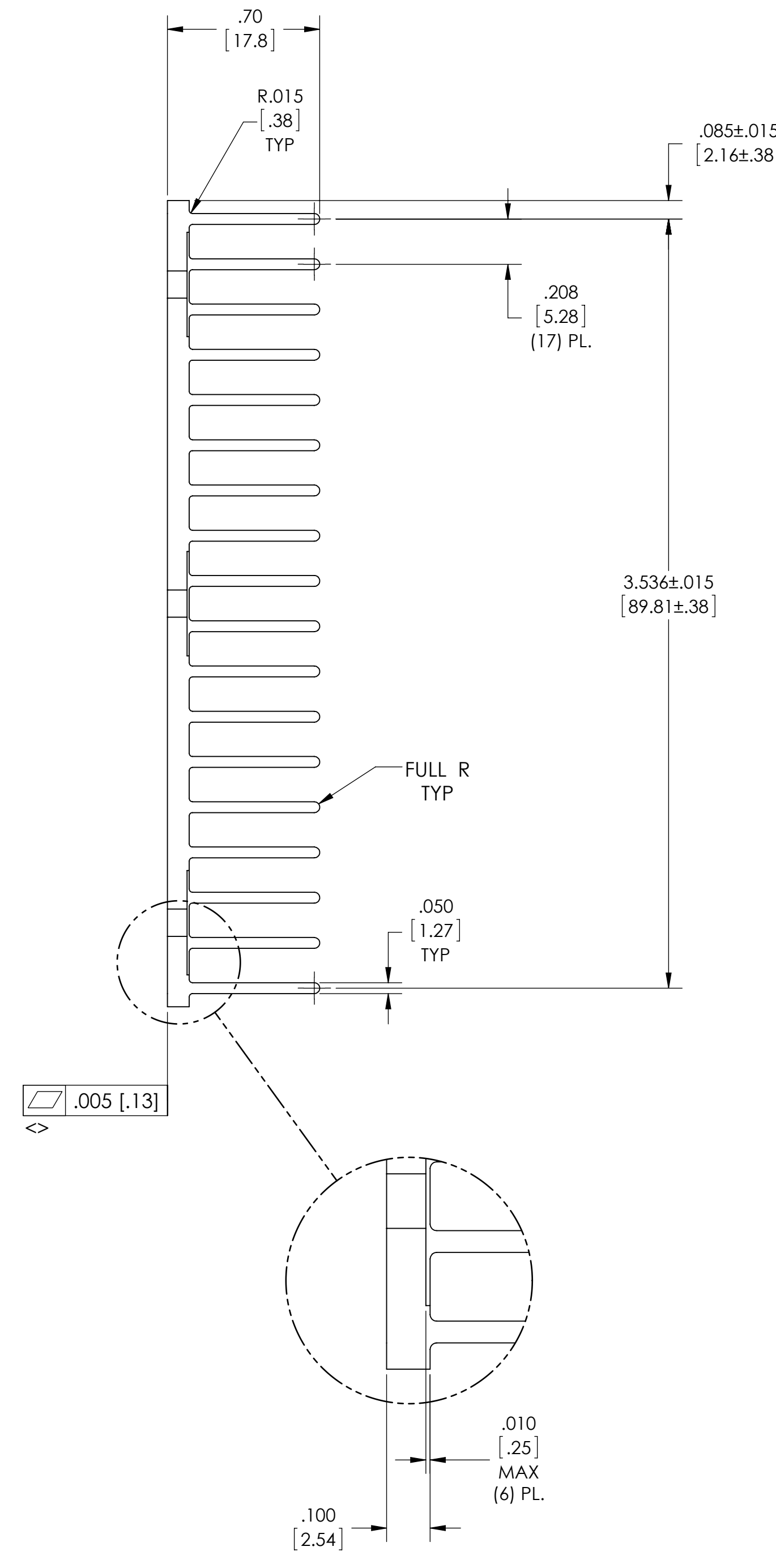
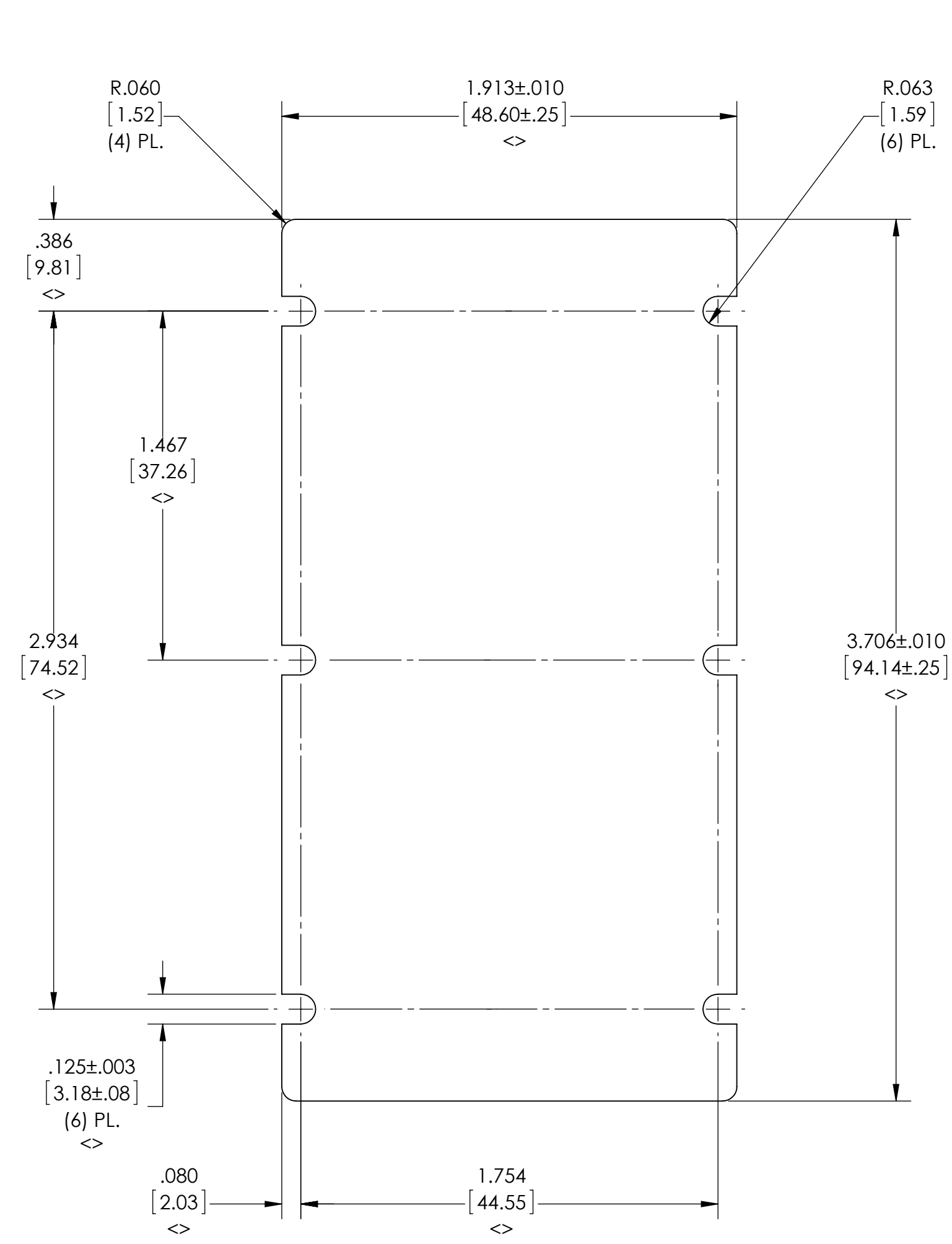

- NOTES:
- MATL: ALUMINUM 6063-T5.
 - CORNERS SHOWN SHARP TO BE .005/[.13] MAX.
 - CLEAR FINISH, RoHS COMPLIANT PER CST-0001. LATEST REVISION PER
 A.) CHROMIUM FREE, OR
 B.) TRIVALENT CHROMIUM IN ACCORDANCE WITH MIL-DTL-5541, TYPE II, CLASS 1A OR 3.
 SEE CST-0003 FOR TYPES OF AVAILABLE FINISHES.
 - ALL DIMENSIONS APPLY AFTER PLATING.
 - \diamond DENOTES CRITICAL CHARACTERISTIC FOR LOT INSPECTION.
 - MAXIMUM STEP BETWEEN ADJOINING CUTTER PASSES TO BE .0005/[.013]
 - BASE PLATE SURFACE PREPARATION PRIOR TO CLEAR FINISH IN ACCORDANCE WITH WS-0016.
 - REMOVE ALL BURRS AND SHARPE EDGES.

DRAWN BY Gary Key	DATE 09/26/2012	VICOR <small>SWD</small>	
UNLESS OTHERWISE SPECIFIED DIMENSIONS ARE: INCH / [MM]		HEATSINK VIBrick X-FLOW .70	
TOLERANCES ARE: DECIMALS ANGLES X.XX [X.X] = +0.01 [0.25] ±1° X.XXX [X.XX] = ±0.005 [0.127]		SIZE D	CAGE CODE 67131
THIRD ANGLE PROJECTION DO NOT SCALE DRAWING		DWG NO 39069	REV 2
SCALE 2:1		SHEET 1 OF 1	