



WDC reserves the right to make changes at any time without notice in order to improve design and supply the best possible product. Information contained herein is provided gratuitously and without liability, to any user. Reasonable efforts have been made to verify the accuracy of the information but no guarantee whatsoever is given as to the accuracy or as to its applicability to particular uses. In every instance, it must be the responsibility of the user to determine the suitability of the products for each application. WDC products are not authorized for use as critical components in life support devices or systems. Nothing contained herein shall be construed as a recommendation to use any product in violation of existing patents or other rights of third parties. The sale of any WDC product is subject to all WDC Terms and Conditions of Sales and Sales Policies, copies of which are available upon request.

Copyright (C) 1981-2020 by The Western Design Center, Inc. All rights reserved, including the right of reproduction in whole or in part in any form.



Contents

- DOCUMENT REVISION HISTORY..... 2
- 1 Introduction and Features 4
 - 1.1 Feature List..... 4
 - 1.2 Functional Block Diagram 4
 - 1.3 Board Diagram 5
 - 1.4 Mechanical Drawing..... 6
 - 1.5 Quick Reference Guide – Memory Map 7
 - 1.6 Quick Reference Guide – Expansion Connectors..... 8
- 2. Connector Descriptions..... 9
 - 2.1 XBus Port (J1) 9
 - 2.2 P4x Port (J3) 9
 - 2.3 P5x Port (J4) 9
 - 2.4 P6x Port (J5) 9
 - 2.5 Micro USB TIDE Port (J6) 10
 - 2.6 SIB IN/OUT Ports (J7/J8)..... 10
- 3 Notices and Ordering Information..... 11
 - 3.1 FCC Compliance..... 11
 - 3.2 Ordering Information 11

1 Introduction and Features

The W65C134SXB is based around the W65C134S which is a feature rich 8-bit microcomputer based on the W65C02 microprocessor. With proven functionality for applications in production that require in-system diagnostics, the SXB is a perfect solution, featuring internal system monitor ROM. If you need robust math for applications in sensing, such as pressure, temperature, revolutions per minute, flow monitoring and control, variable climate control or other systems for scientific, automotive, communications, home appliance/automation, then you'll benefit from our ANSI Standard C compiler.

1.1 Feature List

- W65C134S MCU operating at 3.6864 MHz
- 1 x 32Kbytes SRAM
- 1 x 128Kbytes FLASH ROM (32PLCC Socket) mapped as upper 32KB of Memory Map with overlays off of 2 IO pins from the W65C134S (P34 = FA15; P35 = FAMS).
- 1 x XBus134 Connector (40 Pin) with full Data, Address and Control lines for system expansion
- Serial Interface Bus (SIB) connector for SIB-IN and SIB-OUT for token passing local area network for 8 W65C134SXBs with no external components, just cables.
- 3 x 10 IO Connectors (Ports 4/5/6). Each connector has VSS/VDD and 8 I/O.
- TIDE Programming Interface – FTDI232 UART Interfaced to the Serial Port (P60=RXD/P61=TXD/P62=DTRB Output/P47=DSRB Input) of the W65C134S using the MASK Serial Monitor.
- 5V Powered by Micro USB Connector

1.2 Functional Block Diagram

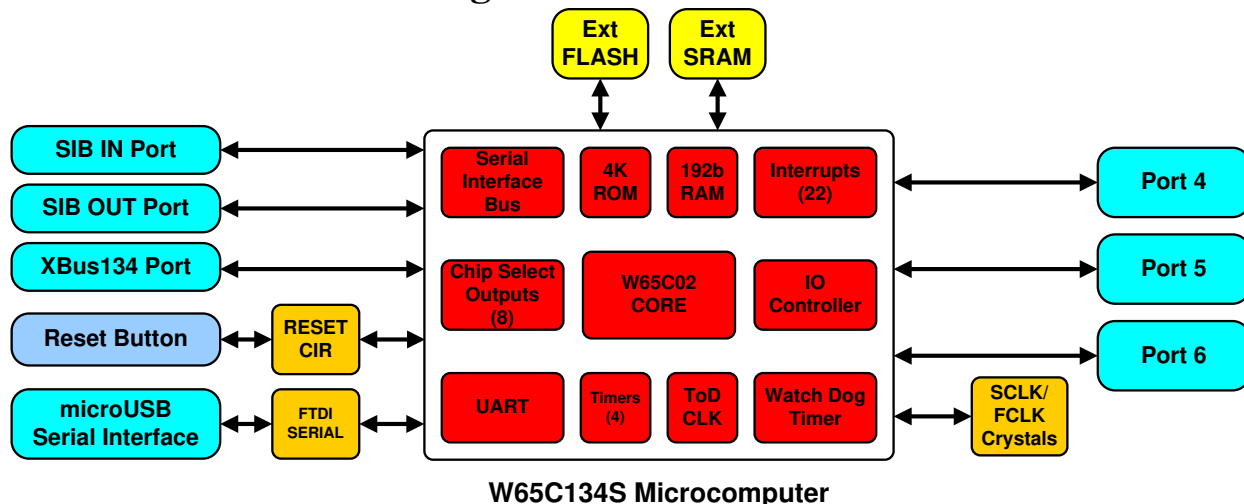

1.3 Board Diagram

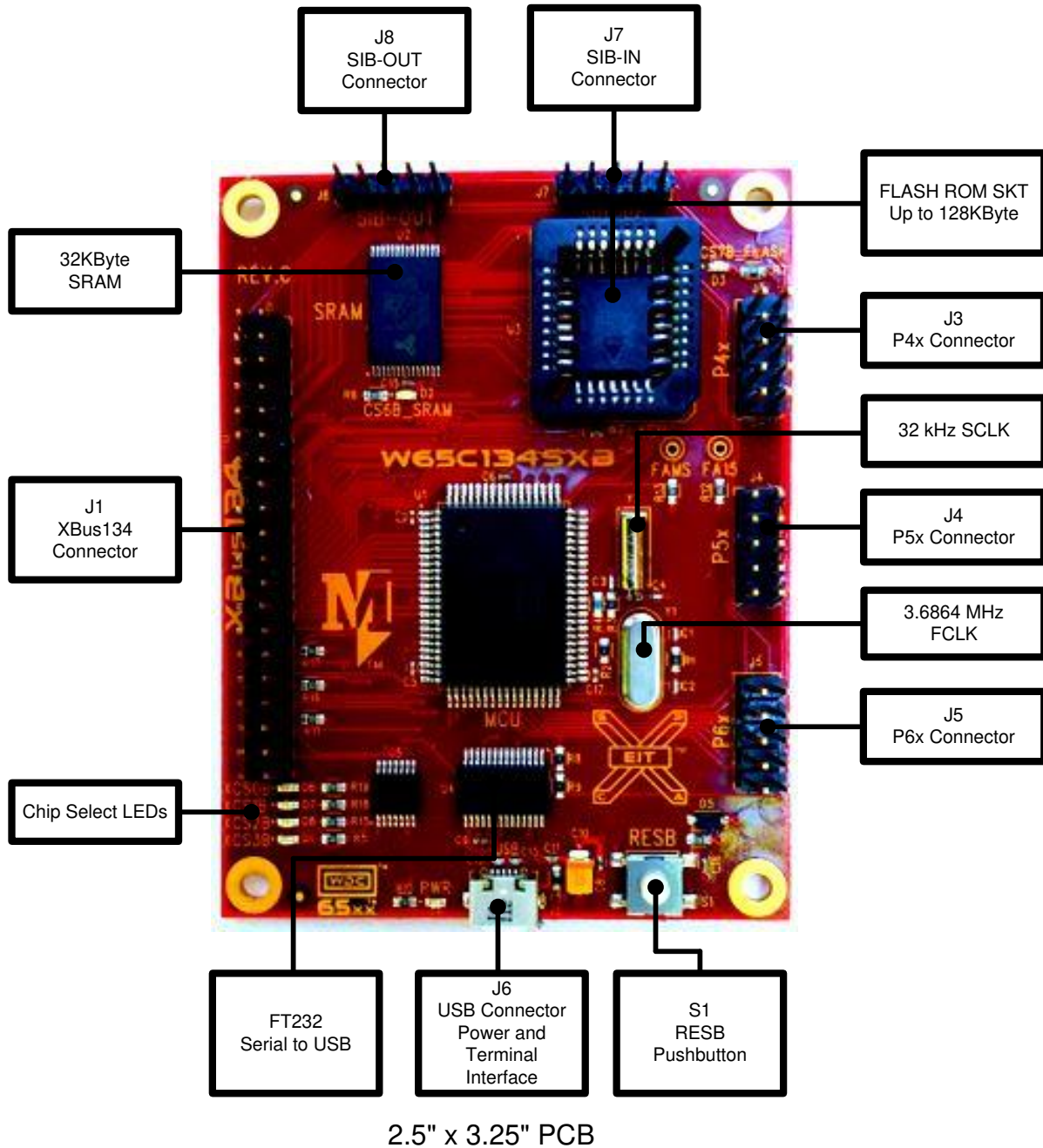

1.4 Mechanical Drawing

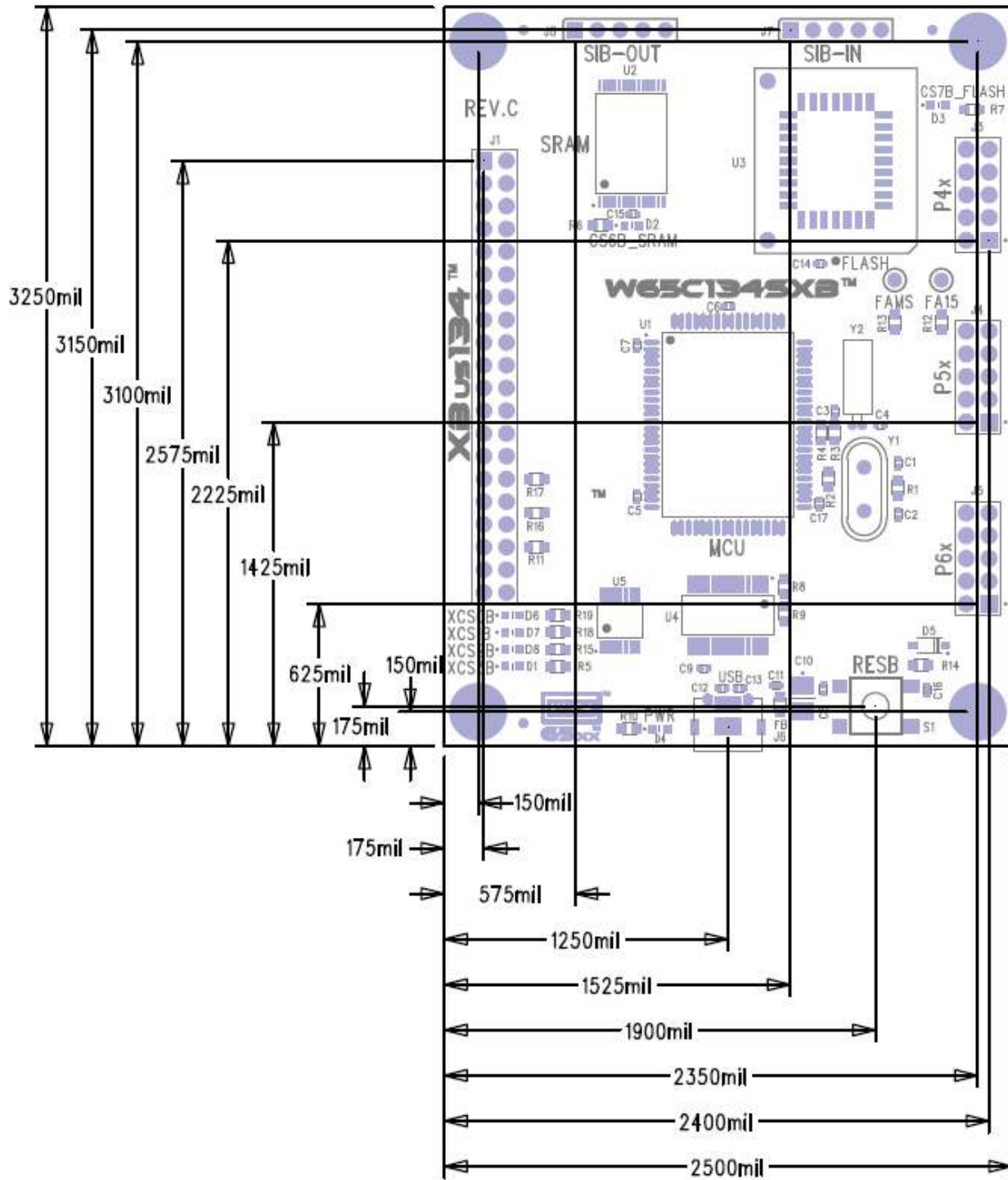



1.5 Quick Reference Guide – Memory Map

W65C134SXB Memory Map				
Start	End	Size	Chip Select	Description
FFD0	FFFF	48B	CS7B BCR7=1	Vector Table: Chip Select (CS7B) when Internal ROM disabled by BCR7=1
F000	FFCF	4KB	CS7B BCR7=1	On-Chip Mask ROM Chip Select (CS7B) when Internal ROM disabled by BCR7=1
8000	FFFF	32KB	CS7B	32K block (28672 available)
0100	7FFF	32KB	CS6B	Chip Select (CS6B) 32K block (32512 available) (Note 1)
4000	5FFF	8KB	CS5B	Chip Select (CS5B) 8K block
2000	3FFF	8KB	CS4B	Chip Select (CS4B) 8K block
0100	1FFF	8KB	CS3B	Chip Select (CS3B) 8K block (7836 available) (Note 1)
0140	01FF	32256	STACK	On-Chip Stack RAM (same as 0040-00FF) when PCS33=0 and PCS36=0 (On-Chip Stack)
0120	013F	32B	CS2B	Chip Select (CS2B) 32 Bytes
0100	011F	32B	CS1B	Chip Select (CS1B) 32 Bytes
0040	00FF	192B	RAM	On-Chip RAM
0030	003F	16B	CS0B	Chip Select (CS0B) 16 Bytes
0000	002F	48B		On-Chip I/O (See I/O Memory Map Table 1-4 of W65C134S Datasheet)

Note 1 - When PCS31=1 and/or PCS32=1 then CS1B and/or CS2B are active. CS3B's and CS6B's memory spaces are reduced by CS1B and/or CS2B memory space in order to prevent external bus conflicts.



1.6 Quick Reference Guide – Expansion Connectors

<i>J1 – XBus134 Connector</i>			
<i>Pin</i>	<i>Signal Name</i>	<i>Pin</i>	<i>Signal Name</i>
1	VDD	2	VSS
3	D0	4	D1
5	D2	6	D3
7	D4	8	D5
9	D6	10	D7
11	A0	12	A1
13	A2	14	A3
15	A4	16	A5
17	A6	18	A7
19	A8	20	A9
21	A10	22	A11
23	A12	24	A13
25	A14	26	A15
27	P30_XCS0B	28	P31_XCS1B
29	P32_XCS2B	30	P41 / IRQB
31	P40 / NMIB	32	RESB
33	CLKOB	34	FLCKOB
35	RUN	36	BE
37	RWB	38	PHI2
39	VSS	40	VDD

<i>J4 – P5x Connector</i>			
<i>Pin</i>	<i>Signal Name</i>	<i>Pin</i>	<i>Signal Name</i>
1	VDD	2	VSS
3	P50	4	P51
5	P52	6	P53
7	P54	8	P55
9	P56	10	P57

<i>J5 – P6x Connector</i>			
<i>Pin</i>	<i>Signal Name</i>	<i>Pin</i>	<i>Signal Name</i>
1	VDD	2	VSS
3	P60 / RXD	4	P61 / TXD
5	P62 / DTRB	6	P63
7	P64 / SCLK	8	P65 / SDAT
9	P66 / CHIN	10	P67 / CHOUT

<i>J7 – SIB-IN Connector</i>			
<i>Pin</i>	<i>Signal Name</i>	<i>Pin</i>	<i>Signal Name</i>
1	VDD	2	P66 / CHIN
3	P64 / SCLK	4	P65 / SDAT
5	VSS		

<i>J3 – P4x Connector</i>			
<i>Pin</i>	<i>Signal Name</i>	<i>Pin</i>	<i>Signal Name</i>
1	VDD	2	VSS
3	P40 / NMIB	4	P41 / IRQB
5	P42	6	P43
7	P44	8	P45
9	P46	10	P47 / DSRB

<i>J8 – SIB-OUT Connector</i>			
<i>Pin</i>	<i>Signal Name</i>	<i>Pin</i>	<i>Signal Name</i>
1	VDD	2	P67 / CHOUT
3	P64 / SCLK	4	P65 / SDAT
5	VSS		



2. Connector Descriptions

Following are descriptions of main board connectors. For Port pins coming from the W65C134S chip, careful review of the [W65C134S Datasheet](#) is recommended.

2.1 XBus Port (J1)

The “XBus134” is a 40-pin male connector with the following signals:

- 8 Data Bus lines (D0-D7)
- 16 Address Bus lines (A0-A15; 64 Kbyte space)
- 3 External Chip Select Lines for expansion (XCS0B-XCS2B)
- 9 Control lines (PHI2, RWB, BE, CLKOB, FCLKOB, RUN, RESB, NMIB, IRQB)
- 4 Power and Ground - 2x VSS (Pins 2 and 49) and 2x VDD (Pins 1 and 50)

2.2 P4x Port (J3)

The P4x Port Connector is an expansion connector that has VDD, VSS and each of the I/O pins from Port 4 on the W65C134S. This is a multipurpose port in that P40 can be an I/O line as well NMIB. P41 can be an I/O line as well as IRQB. P42-P47 are I/O lines in addition to edge interrupt inputs. P47 is used by the mask rom monitor as the DSRB input for the UART.

2.3 P5x Port (J4)

The P5x Port Connector is an expansion connector that has VDD, VSS and each of the I/O pins from Port 5 on the W65C134S. This is again a multipurpose port in that P50-57 can be an I/O lines as well as edge interrupt inputs.

2.4 P6x Port (J5)

The P6x Port Connector is an expansion connector that has VDD, VSS and each of the I/O pins from Port 6 on the W65C134S. This is again a multipurpose port in that P60-67 can be an I/O lines, the Serial Interface Bus, and the UART signals (P60=RXD/P61=TXD/P62=DTRB Output).



2.5 Micro USB TIDE Port (J6)

The Micro USB connector is dual purpose. It is the power connector that powers the board. The FTDI chip that interfaces to the connector has been pre-programmed so that when the board is powered from a USB power on a computer, the chip will request 500mA of current from the host machine. The board can also be powered by any USB port that supplies 5V DC. Note that the board does not have a voltage regulator. 5V DC must be supplied.

In addition to the power, the USB port serves as an interface to WDC's tool suite for debugging and loading programs into the onboard SRAM. An onboard FTDI Serial to USB device interfaces to the W65C134S chip (P60=RXD/P61=TXD/P62=DTRB Output/P47=DSRB Input).

2.6 SIB IN/OUT Ports (J7/J8)

The Serial Interface Bus (SIB) is configured as a token passing Local Area Network, and is intended for inter-chip communications in parallel processing applications. The Serial Interface Bus has four pins associated with its use: CHIN, CHOUT, SDAT, and SCLK. J7 and J8 connectors each have SDAT, SCLK, VSS, and VDD. J7 (SIB IN) has CHIN and J8 (SIB OUT) has CHOUT. Refer to the Quick Reference Guide (Section 1.5 of this document) for J7/J8 pin outs. The SIB has seven (7) registers associated with its use: STATE, SR0, SR1, SR2, SR3, SCSR, and BAR.

Refer to the [W65C134S Datasheet](#) (Section 2.19) for detailed operation information.



3 Notices and Ordering Information

3.1 FCC Compliance

The Western Design Center, Inc. (WDC) provides the enclosed product under the following conditions: This board is intended for use for Engineering Development or Evaluation Purposes ONLY and is not considered by WDC to be a finished consumer product. This board should be handled with caution using good electronics handling practices. This board is compliant per RoHS/Green directives. It does not fall within the scope of directives such as FCC, CE, and UL. It generates uses and can radiate radio frequency energy and has not been tested for compliance with the limits of computing devices pursuant to part 15 of FCC rules.

3.2 Ordering Information

The W65C134SXB is available from WDC Direct and distributors. For information please visit:
<http://www.wdc65xx.com/where-to-buy/>