

STRAIGHT FEMALE-FEMALE ADAPTER

R222.M40.050

Series : SMP-MAX

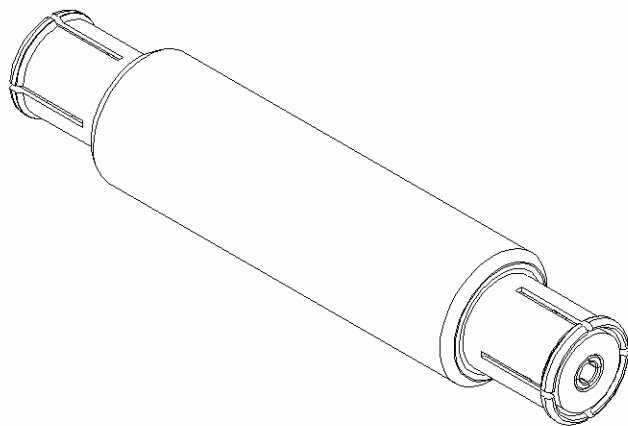
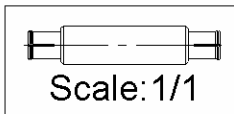
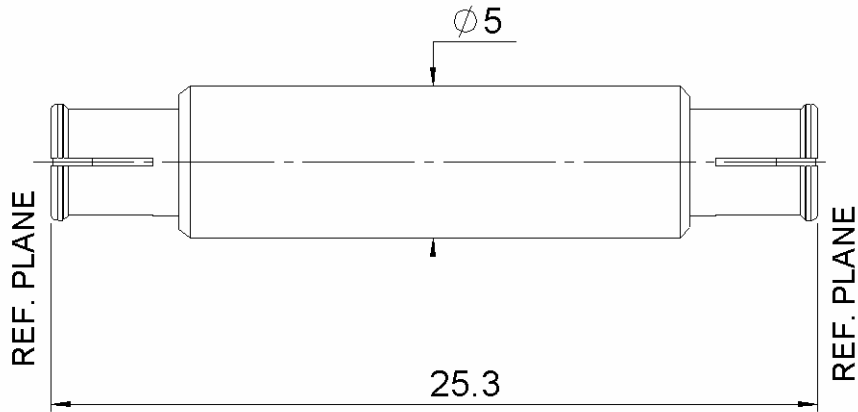

All dimensions are in mm.

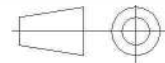

COMPONENTS	MATERIALS	PLATING (μm)
BODY	BRASS	NPGR
CENTER CONTACT	BERYLLIUM COPPER	NPGR
OUTER CONTACT	BERYLLIUM COPPER	NPGR
INSULATOR	PTFE	
GASKET		
OTHERS PARTS		
-	-	-
-	-	-

Issue : 1122 A

In the effort to improve our products, we reserve the right to make changes judged to be necessary.



STRAIGHT FEMALE-FEMALE ADAPTER

R222.M40.050

Series : SMP-MAX

PACKAGING

SPECIFICATION

Standard	Unit	Other
100	'W' option	Contact us

ELECTRICAL CHARACTERISTICS

ENVIRONMENTAL

Impedance	50	Ω
Frequency	0-6	GHz
VSWR	1.25* + 0,0000	x F(GHz) Maxi
Insertion loss	0.15*	\sqrt{F} (GHz) dB Maxi
RF leakage	- (NA)	- F(GHz)) dB Maxi
Voltage rating	335	Veff Maxi
Dielectric withstanding voltage	1000	Veff mini
Insulation resistance	5000	M Ω mini

Operating temperature	-55/+165	$^{\circ}$ C
Hermetic seal	NA	Atm.cm3/s
Panel leakage	NA	

OTHER CHARACTERISTICS

Assembly instruction

Others :

*VSWR: up to 3GHz; 3-6GHz, 1.35 max

*Coaxial Transmission Line Only

*Slide type receptacle+Bullet+Snap type receptacle

Typical VSWR(Board to Board connection):

0-3GHz, 1.2max

Power handling (typical) :

>300W@2.7GHz at 25 $^{\circ}$ C; >200W@2.7GHz at 85 $^{\circ}$ C

Radial working angle : 3 $^{\circ}$ min

Axial working range : 2mm

MECHANICAL CHARACTERISTICS

Center contact retention		
Axial force – Mating end	7	N mini
Axial force – Opposite end	7	N mini
Torque	NA	N.cm mini
Recommended torque		
Mating	NA	N.cm
Panel nut	NA	N.cm
Mating life	100	Cycles mini
Weight	1,9060	g

Issue : 1122 A

In the effort to improve our products, we reserve the right to make changes judged to be necessary.



STRAIGHT FEMALE-FEMALE ADAPTER

R222.M40.050

Series : SMP-MAX

SMP-MAX connecting range

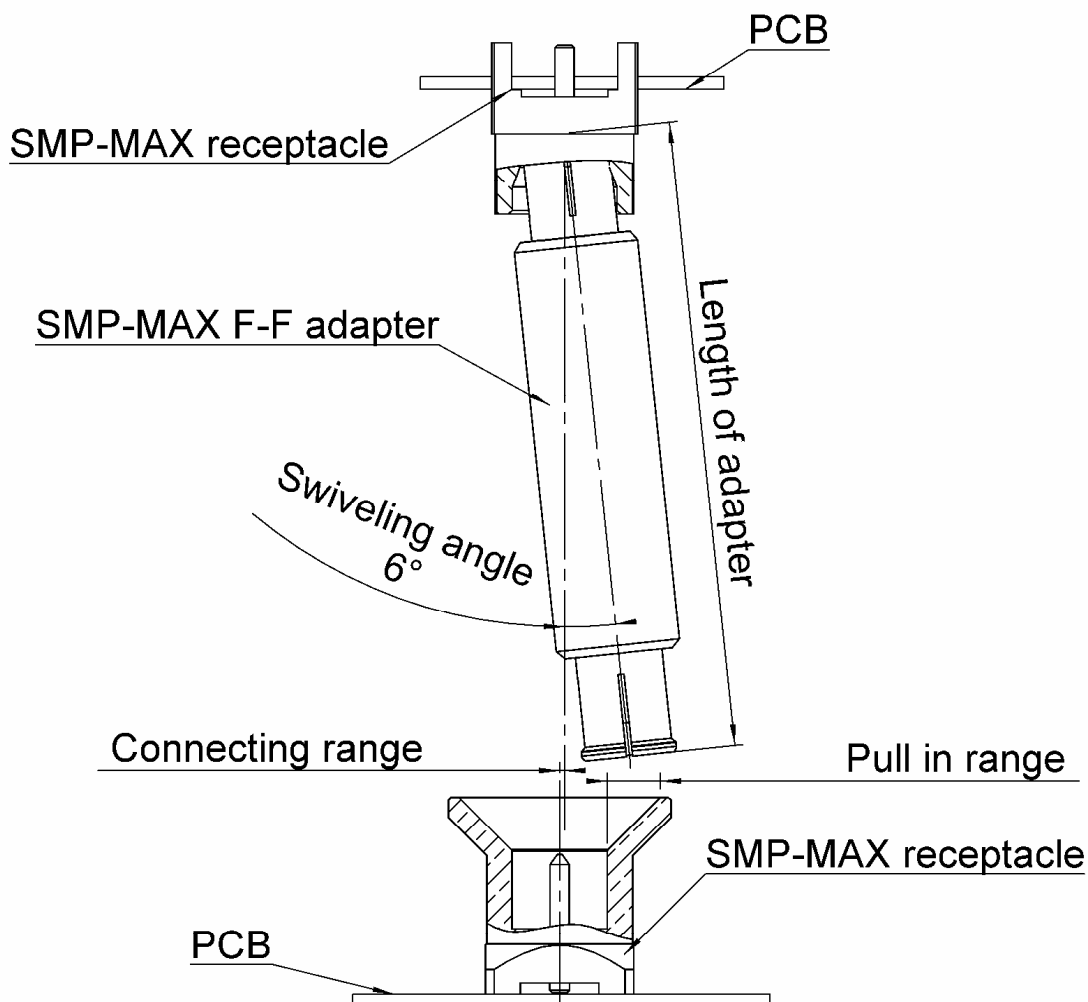

The connecting range represents the maximum misalignment during connection.

The swiveling angle is the maximum possible angle of the adapter in a snap receptacle.

A blind assembly is guaranteed if radial misalignment is smaller than connecting range. Otherwise a manual lead-in is necessary.

Issue : 1122 A

In the effort to improve our products, we reserve the right to make changes judged to be necessary.

RADIALL 

STRAIGHT FEMALE-FEMALE ADAPTER

R222.M40.050

Series : SMP-MAX

SMP-MAX radial and axial working range

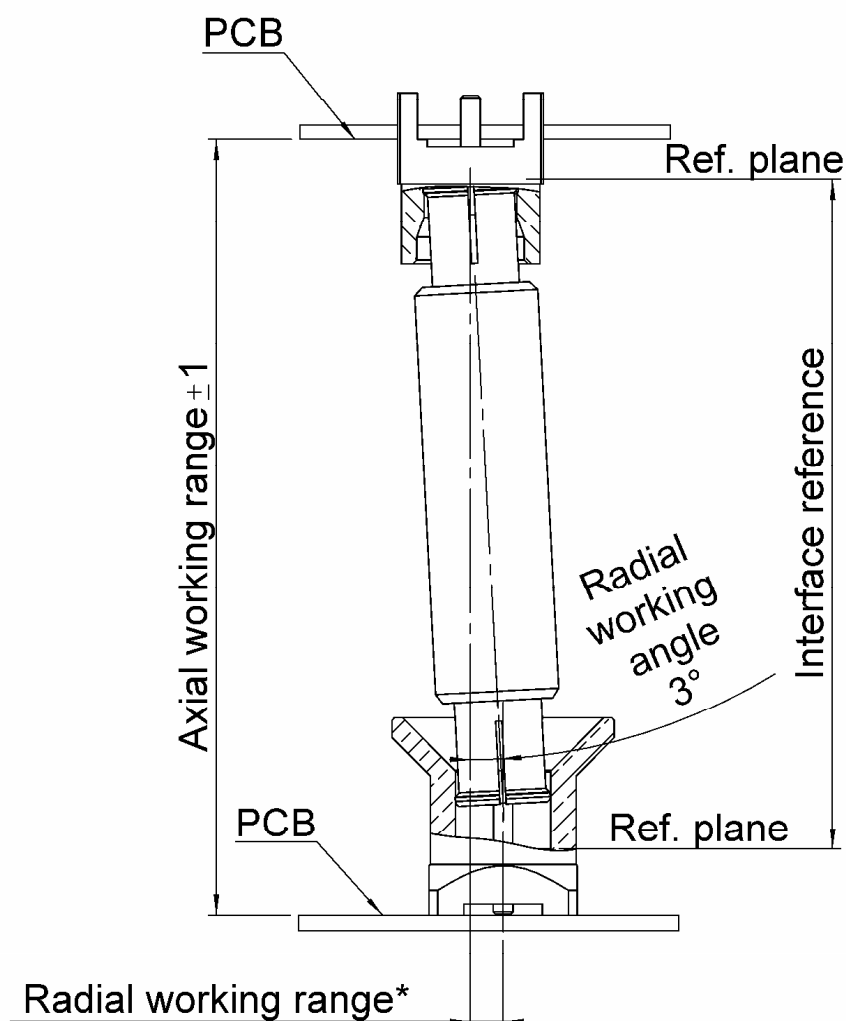

Electrical performance is achieved when radial and axial misalignments are within their working ranges.

* Radial working range = (length of the adapter)* Sin(radial working angle).

Issue : 1122 A

In the effort to improve our products, we reserve the right to make changes judged to be necessary.

RADIALL 