

DO NOT SCALE FROM THIS PRINT

DESIGNED & DIMENSIONED IN INCHES[MILLIMETERS]

SEAM-XX-XX.X-XXX-XX-X-A-XX-K-XR

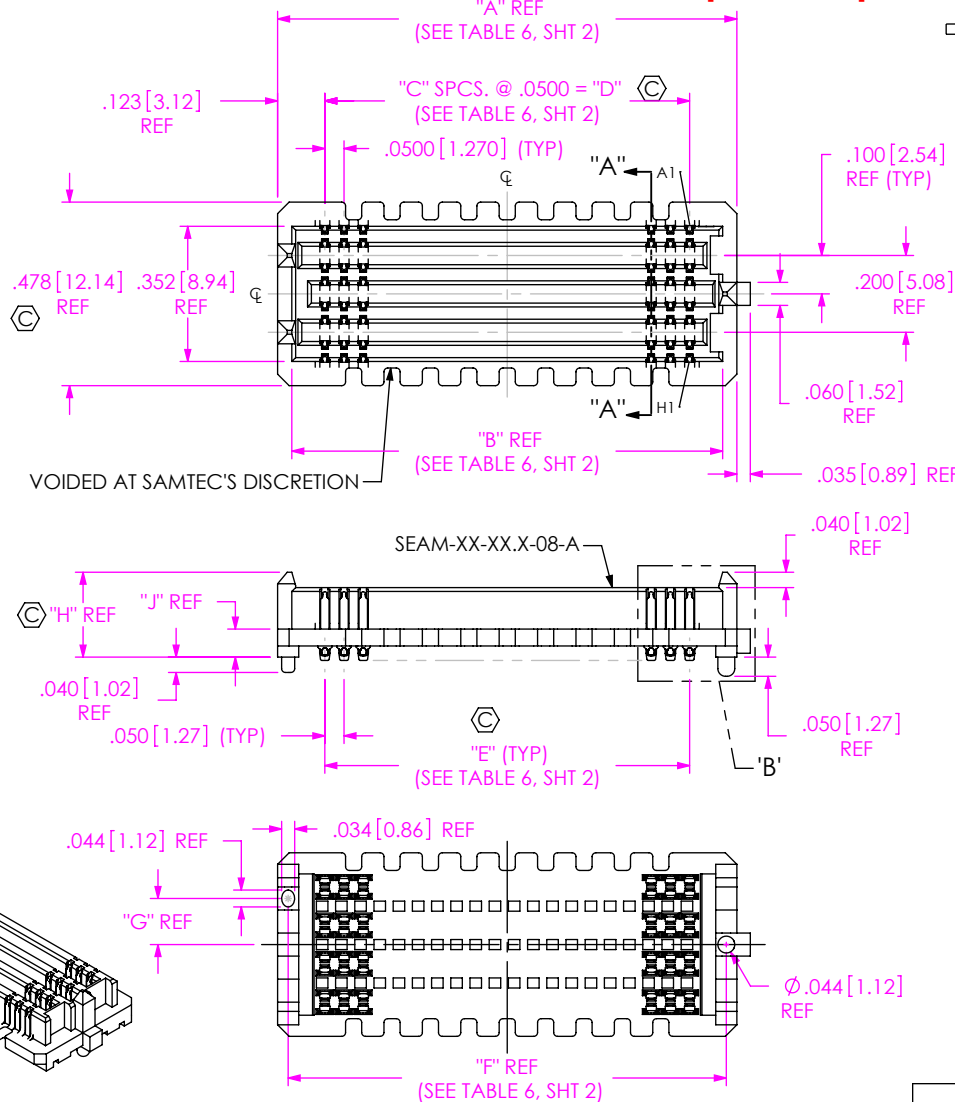

No. OF POSITIONS

- -10, ☒ -15, ** -19 -20,
- ▴ -25, -30, -40, -50 (PER ROW)

LEAD STYLE

- 02.0 (SEE TABLE 1)
- 03.0 (SEE TABLE 1)
- 03.5 (SEE TABLE 1)
- ****-06.5 (SEE TABLE 8, SHT 3)
- 07.0 (SEE TABLE 8, SHT 3)
- 09.0 (SEE TABLE 8, SHT 3)
- 11.0 (SEE TABLE 8, SHT 3)
- *-13.0 (SEE TABLE 8, SHT 3)

PLATING SPECIFICATION

- L: 10μ" LIGHT GOLD IN CONTACT AREA, MATTE TIN ON TAIL
- (LEAD STYLE -02.0 THRU-03.5: USE NEW-SUB-T-1M36-XX.X-L-X)
- (LEAD STYLE -06.5 THRU-13.0: USE NEW-SUB-T-1M38-XX.X-L-X)
- SM: 30μ" SELECTIVE GOLD IN CONTACT AREA, MATTE TIN ON TAIL
- (LEAD STYLE -02.0 THRU-03.5: USE NEW-SUB-T-1M36-XX.X-S-X)
- (LEAD STYLE -06.5 THRU-13.0: USE NEW-SUB-T-1M38-XX.X-S-X)
- S: 30μ" SELECTIVE GOLD IN CONTACT AREA, MATTE TIN ON TAIL
- (LEAD STYLE -02.0 THRU-03.5: USE NEW-SUB-T-1M36-XX.X-S-X)
- (LEAD STYLE -06.5 THRU-13.0: USE NEW-SUB-T-1M38-XX.X-S-X)
- STL: 30μ" SELECTIVE GOLD IN CONTACT AREA, TIN/LEAD(90/10±5%) ON TAIL
- (LEAD STYLE -02.0 THRU-03.5: USE NEW-SUB-T-1M36-XX.X-STL-X)
- (LEAD STYLE -06.5 THRU-13.0: USE NEW-SUB-T-1M38-XX.X-STL-X)
- (STL PLATING NOT AVAILABLE WITH -GP OPTION)

- TAPE & REEL (SEE NOTE 10 & 15)
- TR: TAPE & REEL
- FR: FULL REEL QTY TAPE & REEL
- K DOT (SEE FIG 10, SHT 7)
- DOT APPLICATOR-KAPTON TAPE.
- OPTION
- GP: GUIDE POST (SEE FIG. 9, SHT 6)
- (ONLY AVAILABLE WITH -02.0 LEAD STYLE, 20, 30, 40, & 50 POSITION)

ALIGNMENT PIN (SEE NOTE 6)

SOLDER COMPOSITION & STYLE

- 1: 63% TIN / 37% LEAD
- CHARGE TAIL (USE NEW-T-1M3X-XX.X-XXX-1)
- 2: 95.5% TIN / 3.8% SILVER / .7% COPPER
- CHARGE TAIL (USE NEW-T-1M3X-XX.X-XXX-2)

ROW

- 04: 4 ROWS (SEE FIG 3, SHT 4)
- (NOT AVAILABLE IN -13.0 LEAD STYLE)
- 05: 5 ROWS (SEE FIG 7, SHT 5) (SEE NOTE 14)
- 06: 6 ROWS (SEE FIG 6, SHT 5)
- 08: 8 ROWS (SEE FIG 1)
- 10: 10 ROWS (SEE FIG 4, SHT 4)
- 14: 14 ROWS (SEE FIG 5, SHT 4)

- * = NOT TOOLED
- = 10 POSITION ONLY AVAILABLE IN -04 ROW LEAD STYLES -02.0, -03.0, -03.5, -07.0, -09.0, -11.0. AVAILABLE IN -06 ROW LEAD STYLES -02.0, -03.0, -03.5
- ☒ = ONLY AVAILABLE IN A 10 ROW; 4 ROW, -02.0 LEAD STYLE AVAILABLE
- ▴ = ONLY AVAILABLE WITH -02.0 OR -03.5 LEAD STYLE & 4 ROW; -03.0 AVAILABLE
- ** = ONLY AVAILABLE IN 6 ROW WITH -03.5 LEAD STYLE
- **** = AVAILABLE IN 4, 6, 8 & 10 ROWS. 4 AND 6 ROW NOT ENGINEERING APPROVED
- = 14 ROW ONLY AVAILABLE IN -40 POSITION, -02.0 AND -03.5 BODY HEIGHTS.

- NOTES:
1. Ⓢ REPRESENTS A CRITICAL DIMENSION.
 2. MINIMUM PUSHOUT FORCE: 0.50 LBS.
 3. NOTE DELETED.
 4. 5 ROW SOLDER TAILS ARE NOT SYMMETRICAL WITH BODY WIDTH (.378[9.60] SEE FIG 7, SHT 5).
 5. WHEN APPLICABLE, DIMENSION C8 MUST BE MEASURED USING INSPECTION FIXTURE. USE CO-AU-WI-2003-M FOR PROCESS.
 - 4 ROW: AT-1817-836-1
 - 6, 8 & 10 ROW: AT-1817-836-2
 - 14 ROW: AT-1817-865-02
 6. WITHOUT -A AVAILABLE FOR EXISTING CUSTOMERS ONLY AS OF REVISION AD.
 - 7-9. NOTE DELETED.
 10. ATTACH LABEL "SEAX-0001" TO EACH TAPE & REEL PACKAGE.
 11. SOLDER CHARGE VOLUME IS 0.891 x 10⁻⁵ IN ³ REF.
 12. NOTE DELETED.
 13. MEASURED FIRST AND LAST POSITIONS ONLY. ALL ROWS.
 14. THESE OPTIONS AVAILABLE AS ASO (APPLICATION SPECIFIC OPTIONS) ONLY. PLEASE CONTACT SAMTEC FOR MORE INFORMATION.
 15. ORDERS WILL BE PACKAGED ACCORDING TO THE SAMTEC PACKAGING EFFICIENCY STANDARDS (SPES) FOUND ON WWW.SAMTEC.COM.
 16. NOTE DELETED.

FIG 1
-08: 8 ROW
(SEAM-30-02.0-XXX-08-1-A-XX-K-XR SHOWN)
(SOME CENTER FEATURES REMOVED FOR CLARITY)

TABLE 2	
No. OF ROWS	"G"
-04	.079 [2.01]
-05, -06	.120 [3.05]
-08	.120 [3.05]
-10	.120 [3.05]
-14	.120 [3.05]

TABLE 1				
STYLE	"H"	"J"	BODY CALLOUT	TERMINAL
				SOLDER CHARGE TAIL
-02.0	.221 [5.61]	.073 [1.85]	SEAM-XX-02.0-XX-X	NEW-SUB-T-1M36-02.0-XXX-X
-03.0	.260 [6.60]	.112 [2.84]	SEAM-XX-03.0-XX-X	NEW-SUB-T-1M36-03.0-XXX-X
-03.5	.280 [7.11]	.132 [3.35]	SEAM-XX-03.5-XX-X	NEW-SUB-T-1M36-03.5-XXX-X

(SEE SHEET 3 FOR LEAD STYLES -06.5 THRU -13.0)

UNLESS OTHERWISE SPECIFIED, DIMENSIONS ARE IN INCHES.

TOLERANCES ARE:
DECIMALS: .XX: ±.01 [0.3] ANGLES: 2°
.XXX: ±.005 [0.13]
.XXXX: ±.0020 [0.051]

PROPRIETARY NOTE
THIS DOCUMENT CONTAINS CONFIDENTIAL AND PROPRIETARY INFORMATION AND ALL DESIGN, MANUFACTURING, REPRODUCTION, USE, PATENT RIGHTS AND SALES RIGHTS ARE EXPRESSLY RESERVED BY SAMTEC, INC. THIS DOCUMENT SHALL NOT BE DISCLOSED, IN WHOLE OR PART, TO ANY UNAUTHORIZED PERSON OR ENTITY NOR REPRODUCED, TRANSFERRED OR INCORPORATED IN ANY OTHER PROJECT IN ANY MANNER WITHOUT THE EXPRESS WRITTEN CONSENT OF SAMTEC, INC.

MATERIAL: DO NOT SCALE DRAWING SHEET SCALE: 2:1

INSULATOR: LCP, COLOR: BLACK, UL 94 V-0
TERMINAL: COPPER ALLOY

DESCRIPTION:
.050 PITCH TERMINAL ARRAY ASSEMBLY
DWG. NO.
SEAM-XX-XX.X-XXX-XX-X-A-XX-K-XR
BY: BRATCHER 08-09-2010 SHEET 1 OF 7

520 PARK EAST BLVD, NEW ALBANY, IN 47150
PHONE: 812-944-6733 FAX: 812-948-5047
e-Mail: info@SAMTEC.com code 55322

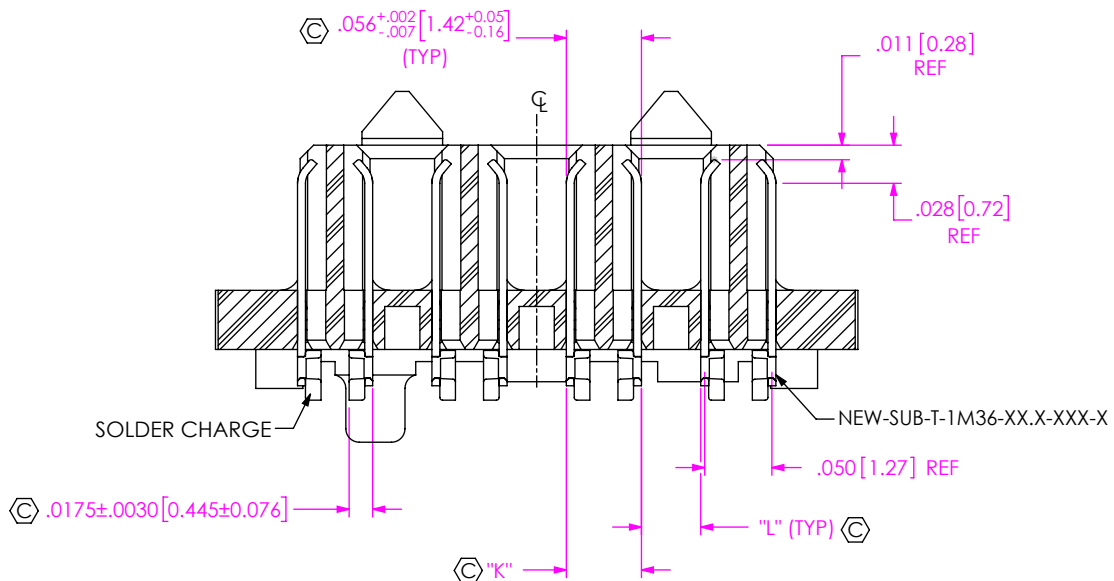
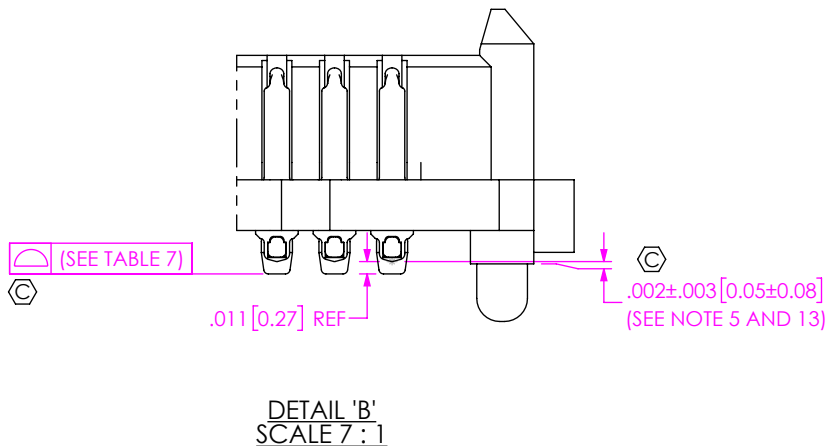

TABLE 3
STACK HEIGHT

SEAM LEAD STYLE	SEAF LEAD STYLE			
	-05.0	-06.0	-06.5	-07.5
-02.0	7mm	8mm	8.5mm	9.5mm
-03.0	8mm	9mm	9.5mm	10.5mm
-03.5	8.5mm	9.5mm	10mm	11mm
-06.5	11.5mm	12.5mm	13mm	14mm
-07.0	12mm	13mm	13.5mm	14.5mm
-09.0	14mm	15mm	15.5mm	16.5mm
-11.0	16mm	17mm	17.5mm	18.5mm
-13.0	18mm	19mm	19.5mm	20.5mm

TABLE 5

LEAD STYLE	"K"		"L"	
-02.0	.0530 - .0590	[1.346] - [1.499]	.0470 - .0410	[1.194] - [1.041]
-03.0	.0530 - .0620	[1.346] - [1.575]	.0470 - .0380	[1.194] - [0.965]
-03.5	.0530 - .0645	[1.346] - [1.638]	.0470 - .0355	[1.194] - [0.902]

TABLE 6

No. OF POS	"A"	"B"	"C"	"D"	"E"	"F"
-10	.696 [17.68]	.622 [15.80]	9	.4500 [11.430]	.4500 [11.430]	.641 [16.28]
-15	.946 [24.03]	.872 [22.15]	14	.7000 [17.780]	.7000 [17.780]	.891 [22.63]
-19	1.146 [29.11]	1.072 [27.23]	18	.9000 [22.860]	.9000 [22.860]	1.091 [27.71]
-20	1.196 [30.38]	1.122 [28.50]	19	.9500 [24.130]	.9500 [24.130]	1.141 [28.98]
-25	1.446 [36.73]	1.372 [34.85]	24	1.2000 [30.480]	1.2000 [30.480]	1.391 [35.33]
-30	1.696 [43.08]	1.622 [41.20]	29	1.4500 [36.830]	1.4500 [36.830]	1.641 [41.68]
-40	2.196 [55.78]	2.122 [53.90]	39	1.9500 [49.530]	1.9500 [49.530]	2.141 [54.38]
-50	2.696 [68.48]	2.622 [66.60]	49	2.4500 [62.230]	2.4500 [62.230]	2.641 [67.08]

TABLE 7

LEAD STYLE	10-30 POS.	40 POS.	50 POS.
-02.0, -03.0, -03.5, -06.5, -07.0, -09.0, -13.0	.006 [0.152]	.009 [0.229]	.009 [0.229]
-11.0	.0085 [0.216]		

PROPRIETARY NOTE
THIS DOCUMENT CONTAINS CONFIDENTIAL AND PROPRIETARY INFORMATION AND ALL DESIGN, MANUFACTURING, REPRODUCTION, USE, PATENT RIGHTS AND SALES RIGHTS ARE EXPRESSLY RESERVED BY SAMTEC, INC. THIS DOCUMENT SHALL NOT BE DISCLOSED, IN WHOLE OR PART, TO ANY UNAUTHORIZED PERSON OR ENTITY NOR REPRODUCED, TRANSFERRED OR INCORPORATED IN ANY OTHER PROJECT IN ANY MANNER WITHOUT THE EXPRESS WRITTEN CONSENT OF SAMTEC, INC.

DO NOT SCALE DRAWING
SHEET SCALE: 2:1

samtec
520 PARK EAST BLVD. NEW ALBANY, IN 47150
PHONE: 812-944-6733 FAX: 812-948-5047
e-Mail info@SAMTEC.com code 55322

DESCRIPTION:
.050 PITCH TERMINAL ARRAY ASSEMBLY
DWG. NO.
SEAM-XX-XX.X-XXX-XX-X-A-XX-K-XR
BY: BRATCHER 08-09-2010 SHEET 2 OF 7

FIG 2
 -06.5 THRU -13.0 LEAD STYLES
 (SEAM-20-09.0-XXX-08-1-A-XR SHOWN)
 (SAME AS FIG 1, EXCEPT AS SHOWN)
 (SOME CENTER FEATURES REMOVED FOR CLARITY)

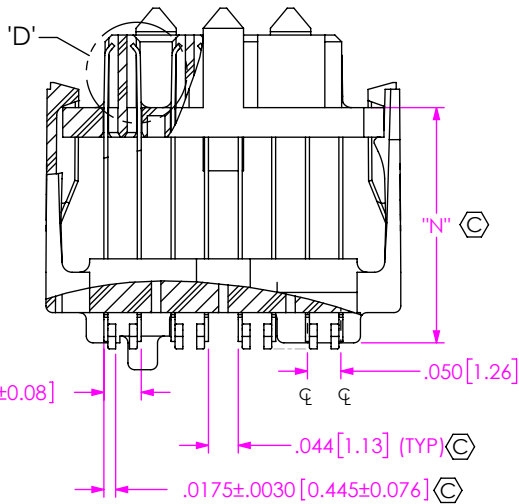
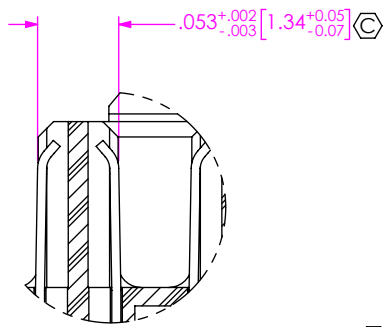
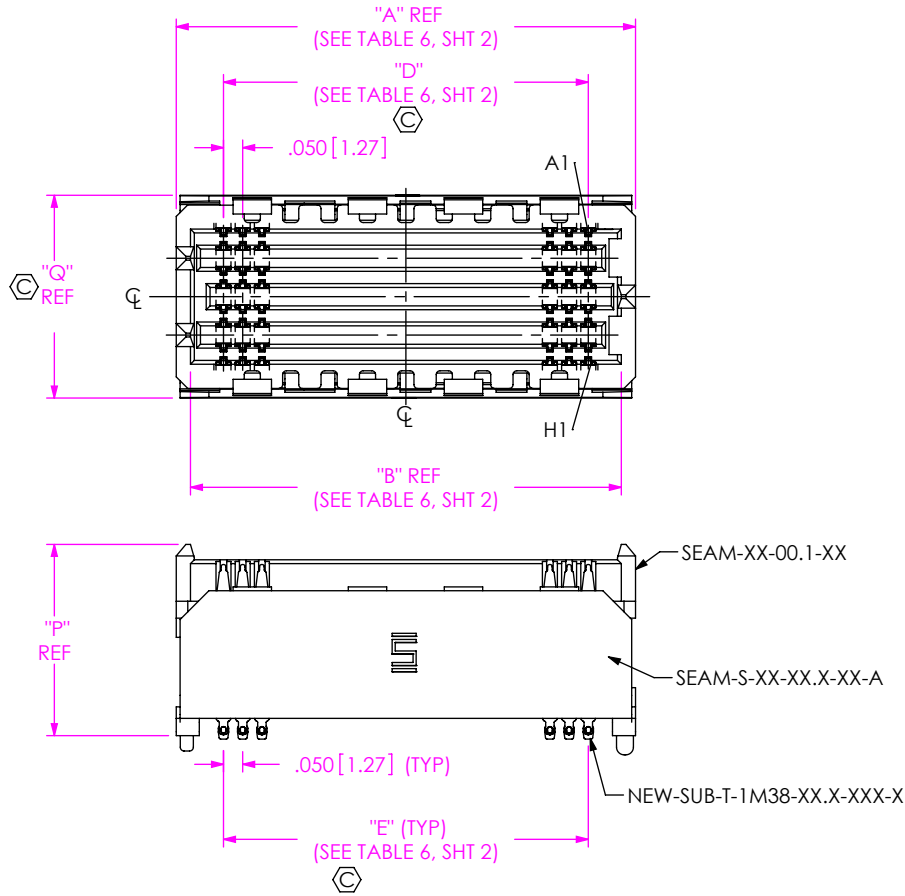

SCALE 3.5:1

F:\DWG\MISC\MKTG\SEAM-XX-XX.X-XXX-XX-X-A-XX-K-XR-MKT.SLDDRW

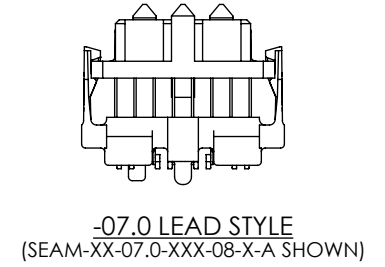
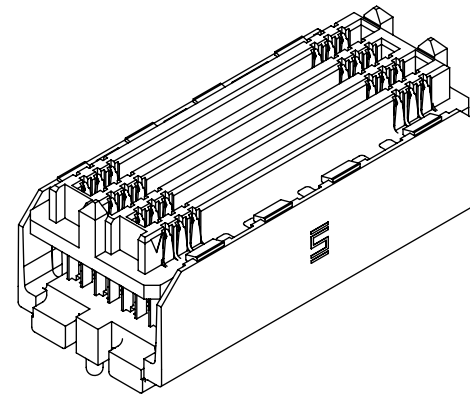

TABLE 8								
ROW	STYLE	"N"	"P"	"Q"	SPACER BODY	TOP BODY	TERMINAL	
-04	-06.5	.252 [6.40]	.400 [10.16]	.328 [8.33]	SEAM-S-XX-06.5-04-A	SEAM-XX-00.1-04	NEW-SUB-T-1M38-06.5-XXX-X	
	-07.0	.271 [6.88]	.417 [10.59]	.328 [8.33]	SEAM-S-XX-07.0-04-A	SEAM-XX-00.1-04	NEW-SUB-T-1M38-07.0-XXX-X	
	-09.0	.350 [8.89]	.496 [12.60]	.328 [8.33]	SEAM-S-XX-09.0-04-A	SEAM-XX-00.1-04	NEW-SUB-T-1M38-09.0-XXX-X	
	-11.0	.429 [10.90]	.575 [14.61]	.328 [8.33]	SEAM-S-XX-11.0-04-A	SEAM-XX-00.1-04	NEW-SUB-T-1M38-11.0-XXX-X	
-05	-07.0	.271 [6.88]	.417 [10.59]	.428 [10.87]	SEAM-S-XX-07.0-06-A	SEAM-XX-00.1-06	NEW-SUB-T-1M38-07.0-XXX-X	
	-09.0	.350 [8.89]	.496 [12.60]	.428 [10.87]	SEAM-S-XX-09.0-06-A	SEAM-XX-00.1-06	NEW-SUB-T-1M38-09.0-XXX-X	
	-11.0	.429 [10.90]	.575 [14.61]	.428 [10.87]	SEAM-S-XX-11.0-06-A	SEAM-XX-00.1-06	NEW-SUB-T-1M38-11.0-XXX-X	
	-13.0	.508 [12.90]	.654 [16.61]	.428 [10.87]	SEAM-S-XX-13.0-06-A	SEAM-XX-00.1-06	NEW-SUB-T-1M38-13.0-XXX-X	
-06	-06.5	.252 [6.40]	.400 [10.16]	.428 [10.87]	SEAM-S-XX-06.5-06-A	SEAM-XX-00.1-06	NEW-SUB-T-1M38-06.5-XXX-X	
	-07.0	.271 [6.88]	.417 [10.59]	.428 [10.87]	SEAM-S-XX-07.0-06-A	SEAM-XX-00.1-06	NEW-SUB-T-1M38-07.0-XXX-X	
	-09.0	.350 [8.89]	.496 [12.60]	.428 [10.87]	SEAM-S-XX-09.0-06-A	SEAM-XX-00.1-06	NEW-SUB-T-1M38-09.0-XXX-X	
	-11.0	.429 [10.90]	.575 [14.61]	.428 [10.87]	SEAM-S-XX-11.0-06-A	SEAM-XX-00.1-06	NEW-SUB-T-1M38-11.0-XXX-X	
-08	-13.0	.508 [12.90]	.654 [16.61]	.428 [10.87]	SEAM-S-XX-13.0-06-A	SEAM-XX-00.1-06	NEW-SUB-T-1M38-13.0-XXX-X	
	-06.5	.252 [6.40]	.400 [10.16]	.528 [13.41]	SEAM-S-XX-06.5-08-A	SEAM-XX-00.1-08	NEW-SUB-T-1M38-06.5-XXX-X	
	-07.0	.271 [6.88]	.417 [10.59]	.528 [13.41]	SEAM-S-XX-07.0-08-A	SEAM-XX-00.1-08	NEW-SUB-T-1M38-07.0-XXX-X	
	-09.0	.350 [8.89]	.496 [12.60]	.528 [13.41]	SEAM-S-XX-09.0-08-A	SEAM-XX-00.1-08	NEW-SUB-T-1M38-09.0-XXX-X	
-10	-11.0	.429 [10.90]	.575 [14.61]	.528 [13.41]	SEAM-S-XX-11.0-08-A	SEAM-XX-00.1-08	NEW-SUB-T-1M38-11.0-XXX-X	
	-13.0	.508 [12.90]	.654 [16.61]	.528 [13.41]	SEAM-S-XX-13.0-08-A	SEAM-XX-00.1-08	NEW-SUB-T-1M38-13.0-XXX-X	
	-06.5	.252 [6.40]	.400 [10.16]	.628 [15.95]	SEAM-S-XX-06.5-10-A	SEAM-XX-00.1-10	NEW-SUB-T-1M38-06.5-XXX-X	
	-07.0	.271 [6.88]	.417 [10.59]	.628 [15.95]	SEAM-S-XX-07.0-10-A	SEAM-XX-00.1-10	NEW-SUB-T-1M38-07.0-XXX-X	
-10	-09.0	.350 [8.89]	.496 [12.60]	.628 [15.95]	SEAM-S-XX-09.0-10-A	SEAM-XX-00.1-10	NEW-SUB-T-1M38-09.0-XXX-X	
	-11.0	.429 [10.90]	.575 [14.61]	.628 [15.95]	SEAM-S-XX-11.0-10-A	SEAM-XX-00.1-10	NEW-SUB-T-1M38-11.0-XXX-X	
	-13.0	.508 [12.90]	.654 [16.61]	.628 [15.95]	SEAM-S-XX-13.0-10-A	SEAM-XX-00.1-10	NEW-SUB-T-1M38-13.0-XXX-X	

PROPRIETARY NOTE
 THIS DOCUMENT CONTAINS CONFIDENTIAL AND PROPRIETARY INFORMATION AND ALL DESIGN, MANUFACTURING, REPRODUCTION, USE, PATENT RIGHTS AND SALES RIGHTS ARE EXPRESSLY RESERVED BY SAMTEC, INC. THIS DOCUMENT SHALL NOT BE DISCLOSED, IN WHOLE OR PART, TO ANY UNAUTHORIZED PERSON OR ENTITY NOR REPRODUCED, TRANSFERRED OR INCORPORATED IN ANY OTHER PROJECT IN ANY MANNER WITHOUT THE EXPRESS WRITTEN CONSENT OF SAMTEC, INC.

DO NOT SCALE DRAWING
 SHEET SCALE: 2:1



520 PARK EAST BLVD, NEW ALBANY, IN 47150
 PHONE: 812-944-6733 FAX: 812-948-5047
 e-Mail info@SAMTEC.com code 55322

DESCRIPTION:
 .050 PITCH TERMINAL ARRAY ASSEMBLY
 DWG. NO.
SEAM-XX-XX.X-XXX-XX-X-A-XX-K-XR
 BY: BRATCHER 08-09-2010 SHEET 3 OF 7

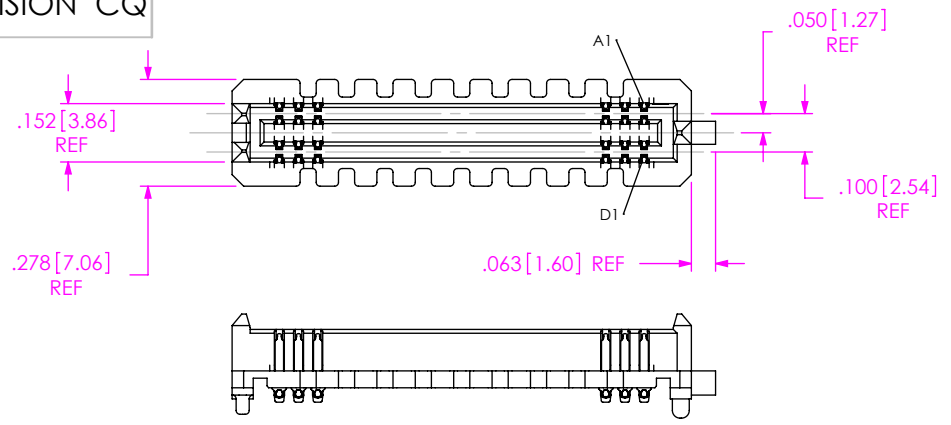

FIG 3
 -04: 4 ROW
 (SEAM-20-02.0-XXX-04-1-A-XR SHOWN)
 (SAME AS FIG 1, EXCEPT AS SHOWN)
 (SOME CENTER FEATURES REMOVED FOR CLARITY)

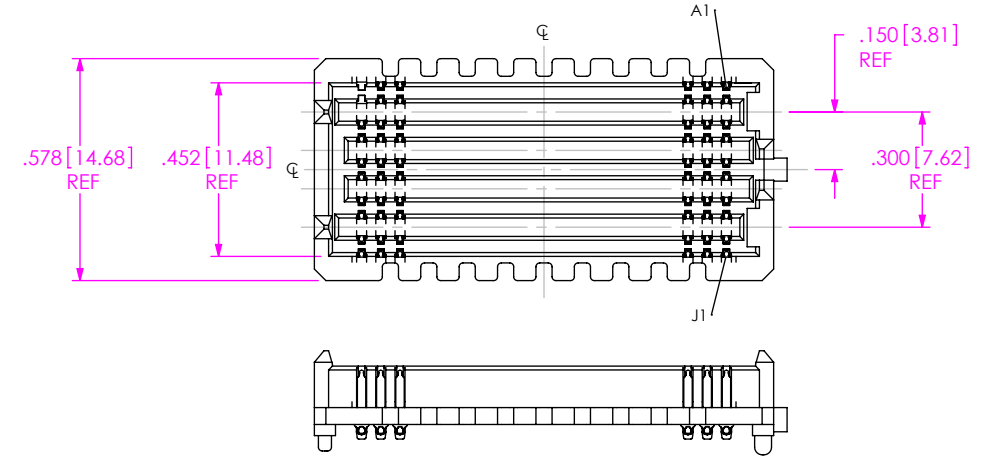

FIG 4
 -10: 10 ROW
 (SEAM-20-02.0-XXX-10-1-A-XR SHOWN)
 (SAME AS FIG 1, EXCEPT AS SHOWN)
 (SOME CENTER FEATURES REMOVED FOR CLARITY)

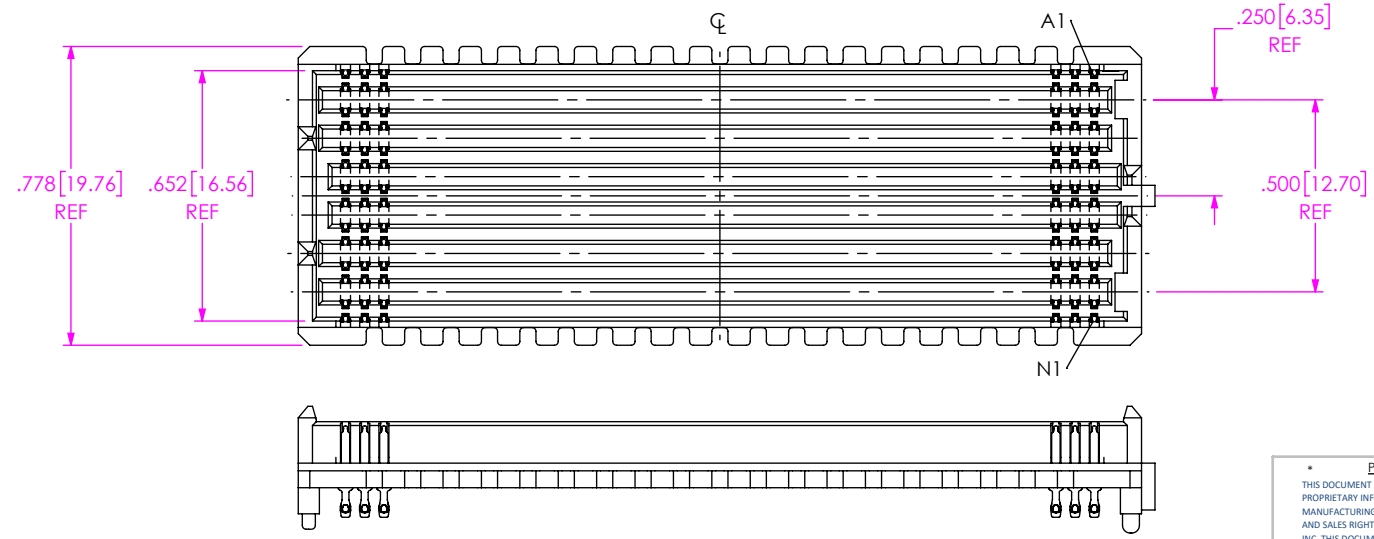

FIG 5
 -14: 14 ROW
 (SEAM-40-03.5-S-14-2-A-K-XR SHOWN)
 (SAME AS FIG 1, EXCEPT AS SHOWN)
 (SOME CENTER FEATURES REMOVED FOR CLARITY)
 (ONLY AVAILABLE IN 40 POSITION, -02.0 AND -03.5 BODY HEIGHTS)

PROPRIETARY NOTE
 * THIS DOCUMENT CONTAINS CONFIDENTIAL AND PROPRIETARY INFORMATION AND ALL DESIGN, MANUFACTURING, REPRODUCTION, USE, PATENT RIGHTS AND SALES RIGHTS ARE EXPRESSLY RESERVED BY SAMTEC, INC. THIS DOCUMENT SHALL NOT BE DISCLOSED, IN WHOLE OR PART, TO ANY UNAUTHORIZED PERSON OR ENTITY NOR REPRODUCED, TRANSFERRED OR INCORPORATED IN ANY OTHER PROJECT IN ANY MANNER WITHOUT THE EXPRESS WRITTEN CONSENT OF SAMTEC, INC.

DO NOT SCALE DRAWING
 SHEET SCALE:2:1



DESCRIPTION:
 .050 PITCH TERMINAL ARRAY ASSEMBLY

DWG. NO.
 SEAM-XX-XX.X-XXX-XX-X-A-XX-K-XR

BY: BRATCHER 08-09-2010 SHEET 4 OF 7

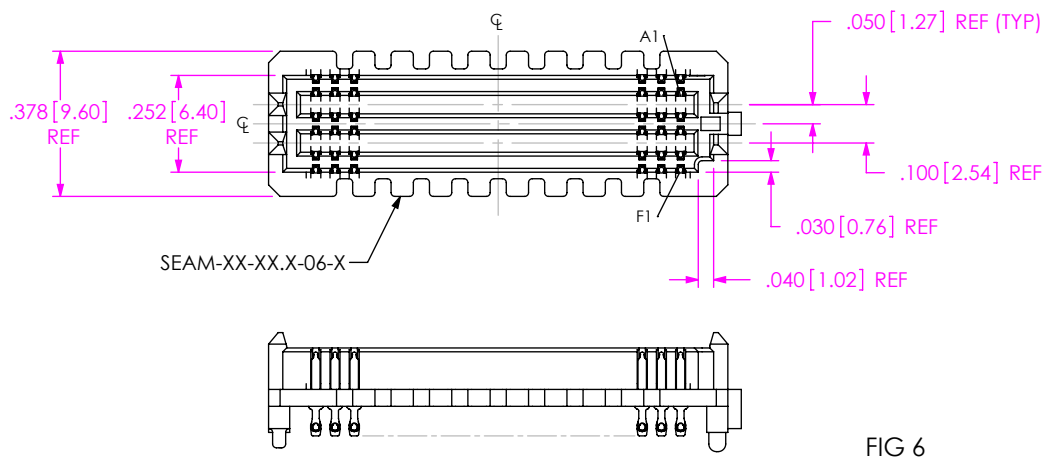
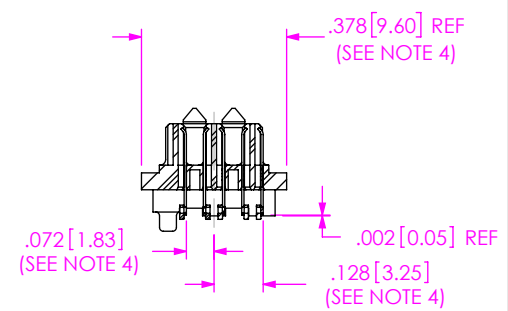
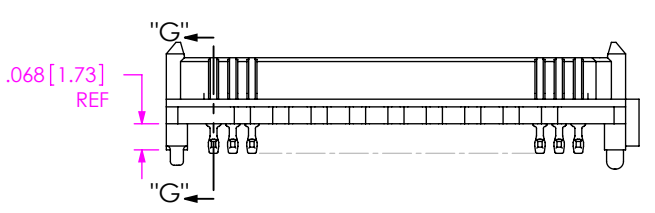
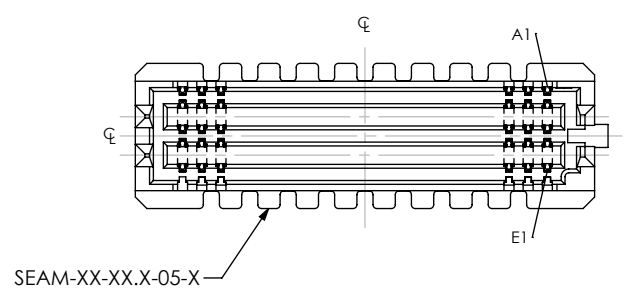
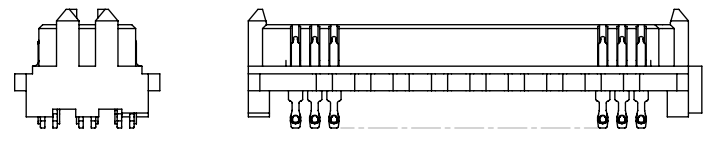
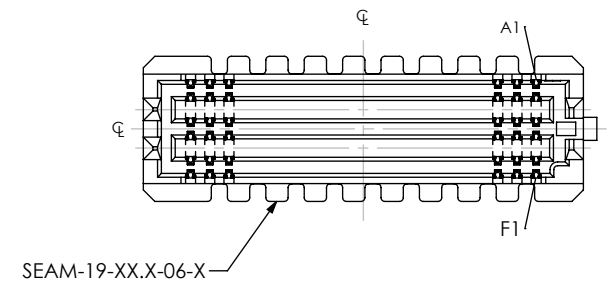

FIG 6
 -06: 6 ROWS
 (SEAM-20-03.0-XXX-06-1-A-XR SHOWN)
 (SAME AS FIG 1, EXCEPT AS SHOWN)
 (SOME CENTER FEATURES REMOVED FOR CLARITY)



SECTION "G"-"G"

FIG 7
 -05: 5 ROWS
 (SEAM-20-03.5-XXX-05-1-A-XR SHOWN)
 (SAME AS FIG 6, EXCEPT AS SHOWN)
 (SOME CENTER FEATURES REMOVED FOR CLARITY)
 (SEE NOTE 4)

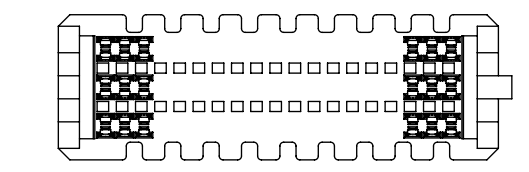

FIG 8
 -19: 19 POSITIONS
 (SEAM-19-03.5-XXX-06-1-XR SHOWN)
 (ONLY AVAILABLE IN -06 ROW WITH -03.5 LEAD STYLE)
 (SAME AS FIG 6, EXCEPT AS SHOWN)
 (SOME CENTER FEATURES REMOVED FOR CLARITY)

PROPRIETARY NOTE
 THIS DOCUMENT CONTAINS CONFIDENTIAL AND PROPRIETARY INFORMATION AND ALL DESIGN, MANUFACTURING, REPRODUCTION, USE, PATENT RIGHTS AND SALES RIGHTS ARE EXPRESSLY RESERVED BY SAMTEC, INC. THIS DOCUMENT SHALL NOT BE DISCLOSED, IN WHOLE OR PART, TO ANY UNAUTHORIZED PERSON OR ENTITY NOR REPRODUCED, TRANSFERRED OR INCORPORATED IN ANY OTHER PROJECT IN ANY MANNER WITHOUT THE EXPRESS WRITTEN CONSENT OF SAMTEC, INC.

DO NOT SCALE DRAWING
 SHEET SCALE: 2:1



520 PARK EAST BLVD. NEW ALBANY, IN 47150
 PHONE: 812-944-6733 FAX: 812-948-5047
 e-Mail info@SAMTEC.com code 55322

DESCRIPTION:
 .050 PITCH TERMINAL ARRAY ASSEMBLY

DWG. NO.
SEAM-XX-XX.X-XXX-XX-X-A-XX-K-XR

BY: BRATCHER 08-09-2010 SHEET 5 OF 7

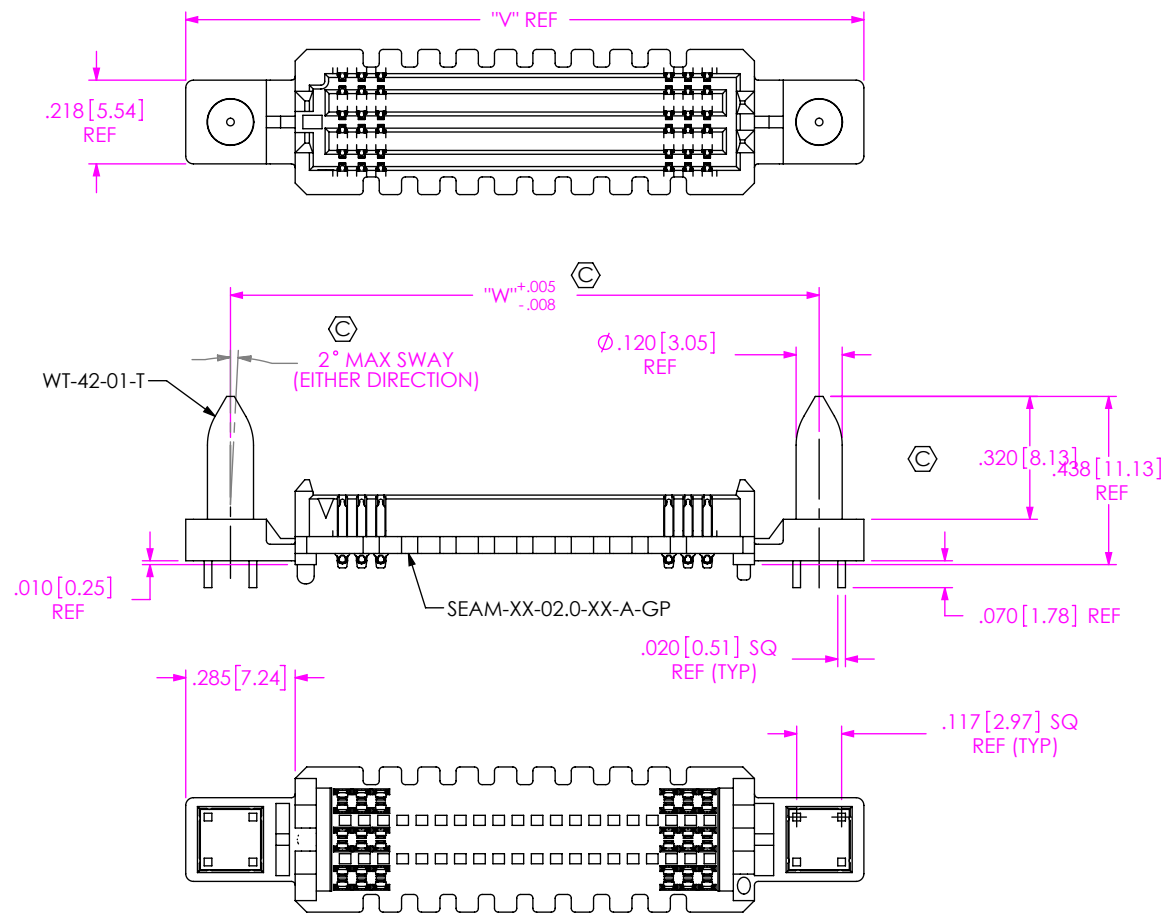

FIG 9
 -GP: GUIDE POST OPTION
 (ONLY AVAILABLE WITH -.02.0 LEAD STYLE, 20, 30, 40, & 50 POSITIONS)
 (MATES WITH SEAF RIGHT ANGLE ONLY)
 (SEAM-20-02.0-XXX-06-1-A-GP-XR SHOWN)
 (SAME AS FIG 1, EXCEPT AS SHOWN)
 (SOME CENTER FEATURES REMOVED FOR CLARITY)

TABLE 9

POSITIONS	"V"	"W"
-20	1.766 [44.86]	1.533 [38.94]
-30	2.266 [57.56]	2.033 [51.64]
-40	2.766 [70.26]	2.533 [64.34]
-50	3.266 [82.96]	3.033 [77.04]

PROPRIETARY NOTE
 THIS DOCUMENT CONTAINS CONFIDENTIAL AND PROPRIETARY INFORMATION AND ALL DESIGN, MANUFACTURING, REPRODUCTION, USE, PATENT RIGHTS AND SALES RIGHTS ARE EXPRESSLY RESERVED BY SAMTEC, INC. THIS DOCUMENT SHALL NOT BE DISCLOSED, IN WHOLE OR PART, TO ANY UNAUTHORIZED PERSON OR ENTITY NOR REPRODUCED, TRANSFERRED OR INCORPORATED IN ANY OTHER PROJECT IN ANY MANNER WITHOUT THE EXPRESS WRITTEN CONSENT OF SAMTEC, INC.

DO NOT SCALE DRAWING

SHEET SCALE: 2:1

samtec

520 PARK EAST BLVD, NEW ALBANY, IN 47150
 PHONE: 812-944-6733 FAX: 812-948-5047
 e-Mail info@SAMTEC.com code 55322

DESCRIPTION:
 .050 PITCH TERMINAL ARRAY ASSEMBLY

DWG. NO.
SEAM-XX-XX.X-XXX-XX-X-A-XX-K-XR

BY: BRATCHER 08-09-2010 SHEET 6 OF 7

TABLE 12											
LEAD STYLE -02.0, -03.0, -03.5											
ROW	K-DOT	"R"	"S"								"T"
			10 POS	15 POS	19 POS	20 POS	25 POS	30 POS	40 POS	50 POS	
-04	K-DOT-.236-.343-.005	.236 [5.99]	.230 [5.84]	.355 [9.02]	.455 [11.56]	.480 [12.19]	.605 [15.37]	.730 [18.54]	.980 [24.89]	1.230 [31.24]	.021 [0.53]
-05, -06	K-DOT-.236-.343-.005	.236 [5.99]	.230 [5.84]	.355 [9.02]	.455 [11.56]	.480 [12.19]	.605 [15.37]	.730 [18.54]	.980 [24.89]	1.230 [31.24]	.071 [1.80]
-08	K-DOT-.325-.450-.005	.325 [8.26]	.186 [4.71]	.311 [7.90]	.411 [10.43]	.436 [11.06]	.561 [14.24]	.686 [17.41]	.936 [23.76]	1.186 [30.11]	.076 [1.93]
-10	K-DOT-.404-.500-.005	.404 [10.26]	.146 [3.71]	.271 [6.88]	.371 [9.42]	.396 [10.06]	.521 [13.23]	.646 [16.41]	.896 [22.76]	1.146 [29.11]	.087 [2.21]
-14	K-DOT-.404-.500-.005	.404 [10.26]	.146 [3.71]	.271 [6.88]	.371 [9.42]	.396 [10.06]	.521 [13.23]	.646 [16.41]	.896 [22.76]	1.146 [29.11]	.187 [4.75]

TABLE 13											
LEAD STYLE -06.5, -07.0, -09.0, -11.0, -13.0											
ROW	K-DOT	"R"	"S"								"T"
			10 POS	15 POS	19 POS	20 POS	25 POS	30 POS	40 POS	50 POS	
-04	K-DOT-.256-.375-.005	.256 [6.50]	.220 [5.59]	.345 [8.76]	.445 [11.30]	.470 [11.94]	.595 [15.11]	.720 [18.29]	.970 [24.64]	1.220 [30.99]	.011 [0.28]
-05, -06	K-DOT-.325-.450-.005	.325 [8.26]	.186 [4.71]	.311 [7.89]	.411 [10.43]	.436 [11.06]	.561 [14.24]	.686 [17.41]	.936 [23.76]	1.186 [30.11]	.027 [0.69]
-08	K-DOT-.404-.500-.005	.404 [10.26]	.146 [3.71]	.271 [6.88]	.371 [9.42]	.396 [10.06]	.521 [13.23]	.646 [16.41]	.896 [22.76]	1.146 [29.11]	.037 [0.94]
-10	K-DOT-.460-.550-.005	.460 [11.68]	.119 [3.01]	.244 [6.18]	.344 [8.72]	.369 [9.36]	.494 [12.53]	.619 [15.71]	.869 [22.06]	1.119 [28.41]	.059 [1.50]

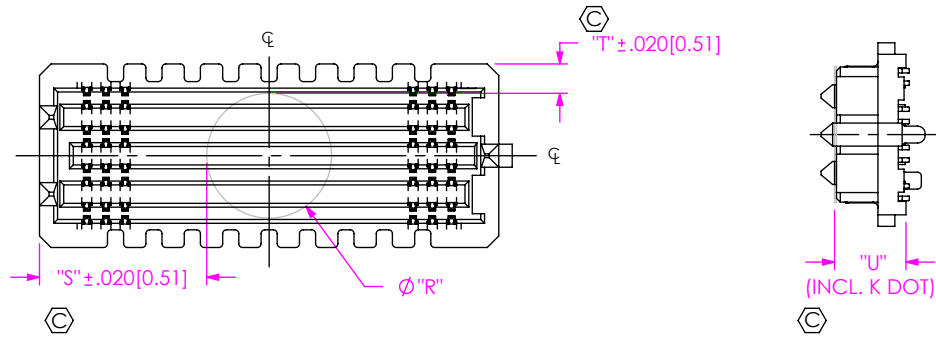

FIG 10
 K: K DOT
 (SEAM-20-02.0-XXX-08-1-A-K-XR SHOWN)
 (SAME AS FIG 1, EXCEPT AS SHOWN)
 (SOME CENTER FEATURES REMOVED FOR CLARITY)

TABLE 14	
LEAD STYLE	"U"
-02.0	.186 [4.72]
-03.0	.225 [5.72]
-03.5	.245 [6.22]
-06.5	.365 [9.27]
-07.0	.382 [9.70]
-09.0	.461 [11.71]
-11.0	.540 [13.72]
-13.0	.619 [15.72]

F:\DWG\MISC\MKTG\SEAM-XX-XX.X-XXX-XX-X-A-XX-K-XR-MKT.SLDDRW

PROPRIETARY NOTE
 THIS DOCUMENT CONTAINS CONFIDENTIAL AND PROPRIETARY INFORMATION AND ALL DESIGN, MANUFACTURING, REPRODUCTION, USE, PATENT RIGHTS AND SALES RIGHTS ARE EXPRESSLY RESERVED BY SAMTEC, INC. THIS DOCUMENT SHALL NOT BE DISCLOSED, IN WHOLE OR PART, TO ANY UNAUTHORIZED PERSON OR ENTITY NOR REPRODUCED, TRANSFERRED OR INCORPORATED IN ANY OTHER PROJECT IN ANY MANNER WITHOUT THE EXPRESS WRITTEN CONSENT OF SAMTEC, INC.



520 PARK EAST BLVD, NEW ALBANY, IN 47150
 PHONE: 812-944-6733 FAX: 812-948-5047
 e-Mail info@SAMTEC.com code 55322

DO NOT SCALE DRAWING

SHEET SCALE: 2:1

DESCRIPTION:
 .050 PITCH TERMINAL ARRAY ASSEMBLY

DWG. NO.
 SEAM-XX-XX.X-XXX-XX-X-A-XX-K-XR

BY: BRATCHER 08-09-2010 SHEET 7 OF 7