

THIS DRAWING IS UNPUBLISHED.

RELEASED FOR PUBLICATION

20

© COPYRIGHT 20 BY -

ALL RIGHTS RESERVED.

REVISIONS

P	LTR	DESCRIPTION	DATE	DWN	APVD
	A	INITIAL RELEASE	23JUN2015	DL	CW
	A1	ECR-17-001721	14FEB2017	YC	CW
	B	ECR-20-008190	10OCT2020	WQR	CW

NOTES:

- 1. TECHNICAL CHARACTERISTICS:
HOUSING MATERIAL: DIE CAST ALUMINIUM ALLOY
SURFACE TREATMENT: POWDER COATED, GREY
DEGREE OF PROTECTION: IP65 (MATED)

注释:

- 1. 技术参数:
下壳材料: 铝合金
表面处理: 粉末喷涂, 灰色
防护等级: IP65 (配合)

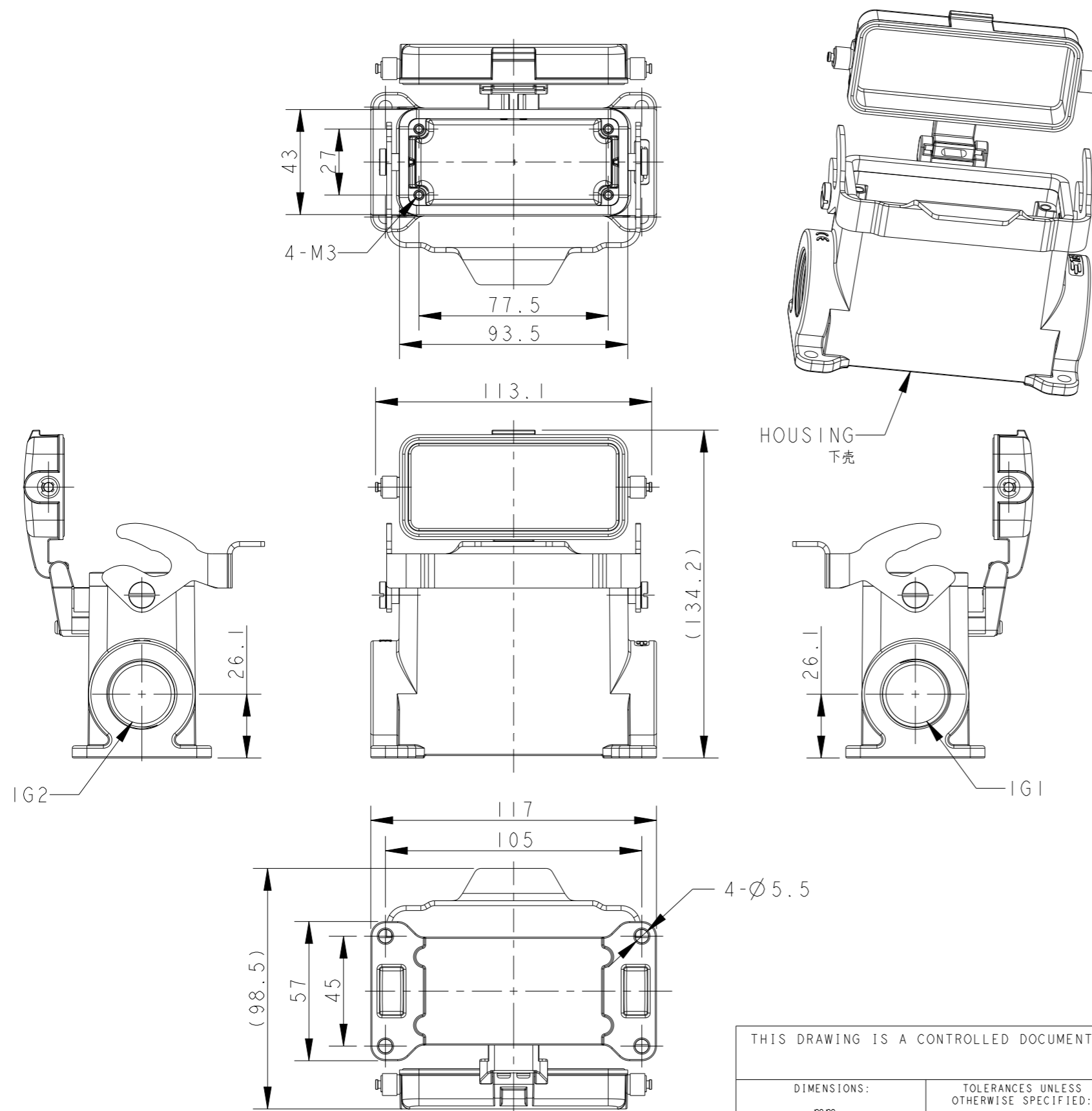

TYPE 1: TI660163XXX-100 HI6B-SDRHM-LB-PG/M
 类型 1: TI660163XXX-100 HI6BT壳, 表面安装, 彩锌单扣, PG/M, 高结构, 带金属保护盖, 灰色粉末喷涂

THIS DRAWING IS A CONTROLLED DOCUMENT.		DWN	23JUN2015	STE TE Connectivity	NAME HI6B-SDRHM-LB-PG/M
DIMENSIONS: mm		DAVID LI	23JUN2015		
TOLERANCES UNLESS OTHERWISE SPECIFIED:		CHK	CHRIS WANG		
		APVD	XIANG XU		
0 PLC ±- 1 PLC ±- 2 PLC ±- 3 PLC ±- 4 PLC ±- ANGLES ±- FINISH		PRODUCT SPEC	108-137013	SIZE	A3
MATERIAL		APPLICATION SPEC	114-137013	CAGE CODE	-
		WEIGHT	-	DRAWING NO	©-TI66016XXXXX00
		Customer Drawing	SCALE	1:2	SHEET
				1	OF
				3	REV
				B	

REVISIONS

P	LTR	DESCRIPTION	DATE	DWN	APVD
-	-	SEE SHEET 1	-	-	-

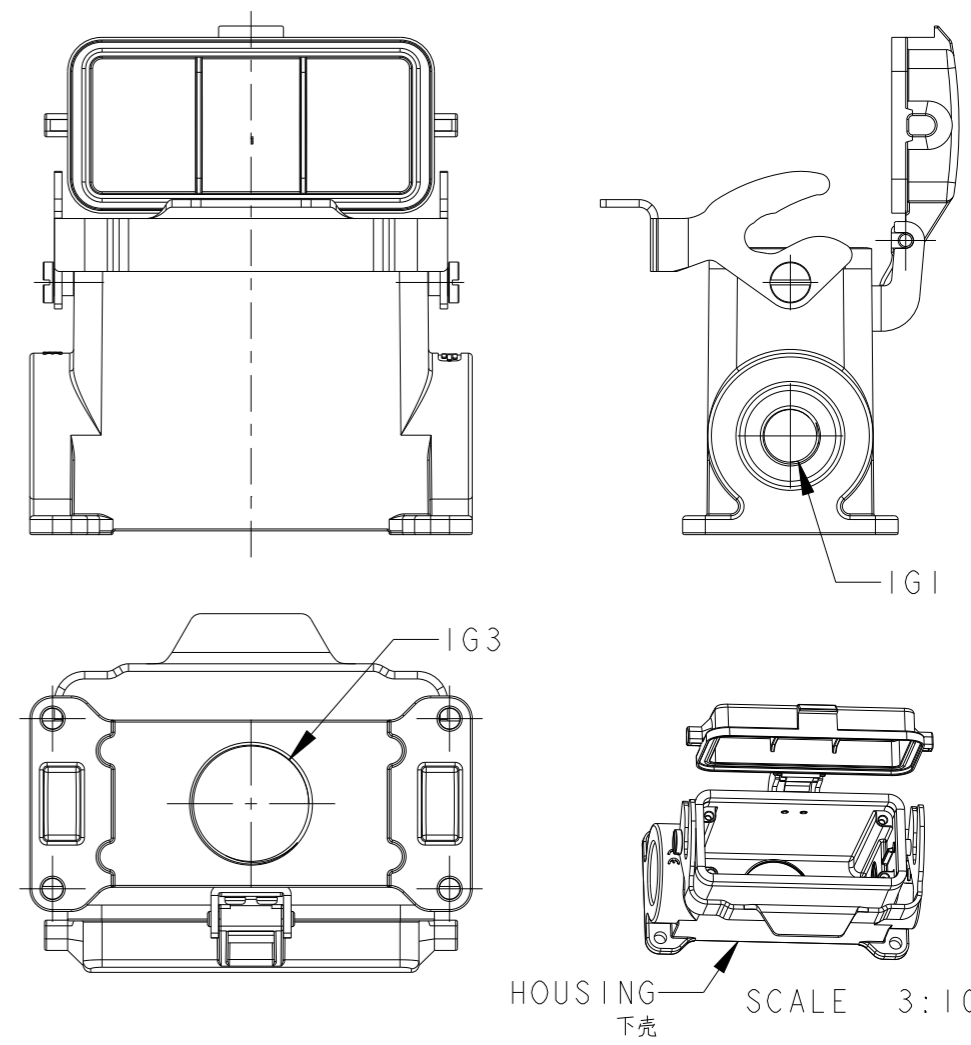
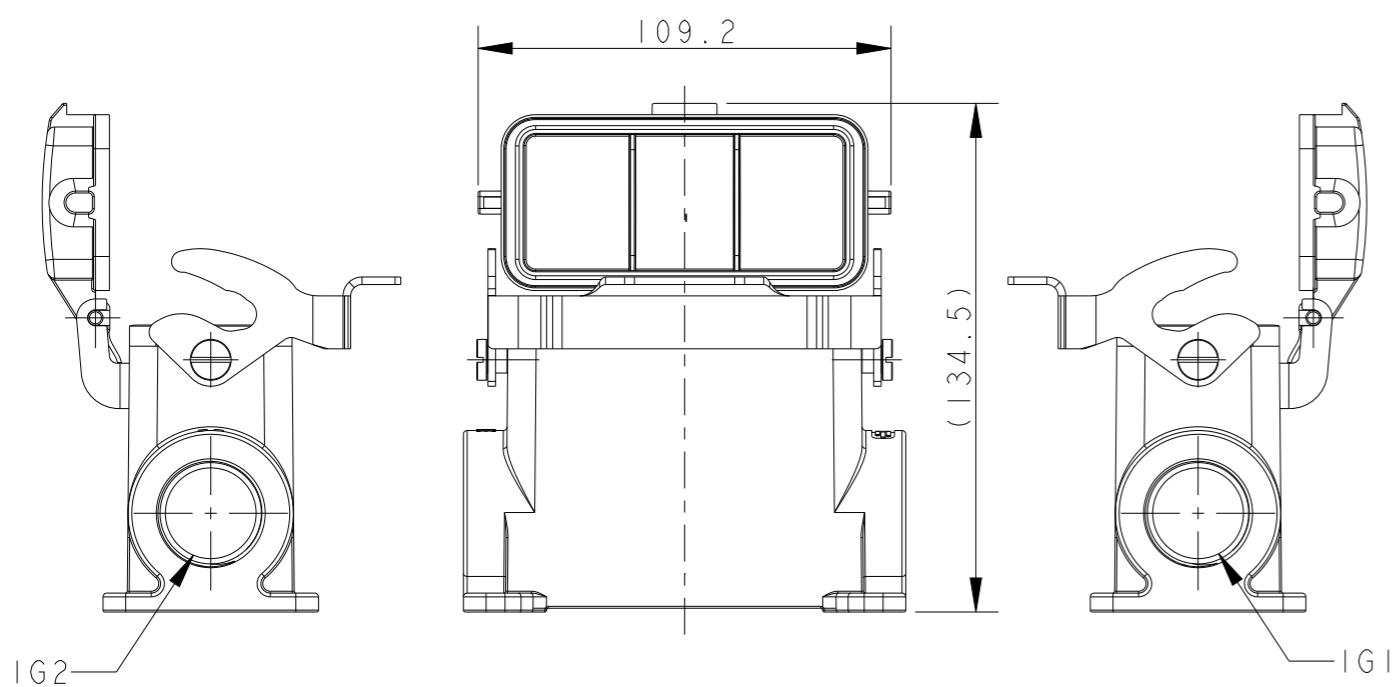
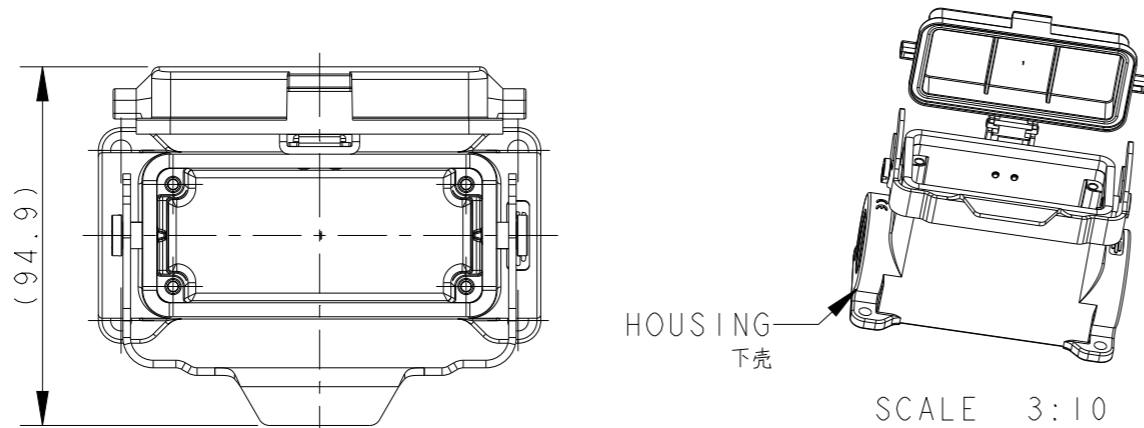

TYPE 2: T1660163XXX-000 HI6B-SDRH-LB-PG/M
 OTHER SPEC REFER TO TYPE 1
 类型 2: T1660163XXX-000HI6B下壳, 表面安装, 彩锌单扣, PG/M,
 高结构, 带塑料保护盖, 灰色粉末喷涂, 其余规范参照类型1

TYPE 3: T1660160932-000 HI6B-SDRH-LB-M32/PG9
 OTHER SPEC REFER TO TYPE 2
 类型 3: T1660160932-000 HI6B下壳, 表面安装, 彩锌单扣, 侧出PG9,
 底出M32, 高结构, 带塑料保护盖, 灰色粉末喷涂, 其余规范参照类型2

THIS DRAWING IS A CONTROLLED DOCUMENT.		DWN DAVID LI 23JUN2015	 TE Connectivity NAME HI6B-SDRHM-LB-PG/M				
DIMENSIONS: mm		CHK CHRIS WANG 23JUN2015					
TOLERANCES UNLESS OTHERWISE SPECIFIED:		APVD XIANG XU 23JUN2015					
0 PLC ±- 1 PLC ±- 2 PLC ±- 3 PLC ±- 4 PLC ±- ANGLES ±-		PRODUCT SPEC 108-137013					
MATERIAL		APPLICATION SPEC 114-137013	SIZE A3	CAGE CODE -	DRAWING NO C-T166016XXXXX00	RESTRICTED TO -	
-		WEIGHT -	Customer Drawing		SCALE 1:2	SHEET 2 OF 3	REV B

THIS DRAWING IS UNPUBLISHED. RELEASED FOR PUBLICATION 20
 © COPYRIGHT 20 BY - ALL RIGHTS RESERVED.

REVISIONS					
P	LTR	DESCRIPTION	DATE	DWN	APVD
	-	SEE SHEET 1	-	-	-

NOTES:
 SEE SHEET 1
 注释:
 参照 SHEET 1

PART NUMBER 料号	PART DESCRIPTION 描述	IG1	IG2	IG3	TYPE 类型
TI660163121-100	H16B HOUSING, SURFACE MOUNTED, METAL SINGLE LOCKING, PG21, HIGH CONSTRUCTION, METAL PROTECTION COVER, POWDER COATED, GREY H16B下壳, 表面安装, 彩锌单扣, PG21, 高结构, 带金属保护盖, 灰色粉末喷涂	PG21	-	-	TYPE 1 类型1
TI660163129-100	H16B HOUSING, SURFACE MOUNTED, METAL SINGLE LOCKING, PG29, HIGH CONSTRUCTION, METAL PROTECTION COVER, POWDER COATED, GREY H16B下壳, 表面安装, 彩锌单扣, PG29, 高结构, 带金属保护盖, 灰色粉末喷涂	PG29	-	-	
TI660163132-100	H16B HOUSING, SURFACE MOUNTED, METAL SINGLE LOCKING, M32, HIGH CONSTRUCTION, METAL PROTECTION COVER, POWDER COATED, GREY H16B下壳, 表面安装, 彩锌单扣, M32, 高结构, 带金属保护盖, 灰色粉末喷涂	M32	-	-	
TI660163221-100	H16B HOUSING, SURFACE MOUNTED, METAL SINGLE LOCKING, 2PG21, HIGH CONSTRUCTION, METAL PROTECTION COVER, POWDER COATED, GREY H16B下壳, 表面安装, 彩锌单扣, 2PG21, 高结构, 带金属保护盖, 灰色粉末喷涂	PG21	PG21	-	
TI660163229-100	H16B HOUSING, SURFACE MOUNTED, METAL SINGLE LOCKING, 2PG29, HIGH CONSTRUCTION, METAL PROTECTION COVER, POWDER COATED, GREY H16B下壳, 表面安装, 彩锌单扣, 2PG29, 高结构, 带金属保护盖, 灰色粉末喷涂	PG29	PG29	-	
TI660163232-100	H16B HOUSING, SURFACE MOUNTED, METAL SINGLE LOCKING, 2M32, HIGH CONSTRUCTION, METAL PROTECTION COVER, POWDER COATED, GREY H16B下壳, 表面安装, 彩锌单扣, 2M32, 高结构, 带金属保护盖, 灰色粉末喷涂	M32	M32	-	TYPE 2 类型2
TI660163121-000	H16B HOUSING, SURFACE MOUNTED, METAL SINGLE LOCKING, PG21, HIGH CONSTRUCTION, PLASTIC PROTECTION COVER, POWDER COATED, GREY H16B下壳, 表面安装, 彩锌单扣, PG21, 高结构, 带塑料保护盖, 灰色粉末喷涂	PG21	-	-	
TI660163129-000	H16B HOUSING, SURFACE MOUNTED, METAL SINGLE LOCKING, PG29, HIGH CONSTRUCTION, PLASTIC PROTECTION COVER, POWDER COATED, GREY H16B下壳, 表面安装, 彩锌单扣, PG29, 高结构, 带塑料保护盖, 灰色粉末喷涂	PG29	-	-	
TI660163125-000	H16B HOUSING, SURFACE MOUNTED, METAL SINGLE LOCKING, M25, HIGH CONSTRUCTION, PLASTIC PROTECTION COVER, POWDER COATED, GREY H16B下壳, 表面安装, 彩锌单扣, M25, 高结构, 带塑料保护盖, 灰色粉末喷涂	M25	-	-	
TI660163132-000	H16B HOUSING, SURFACE MOUNTED, METAL SINGLE LOCKING, M32, HIGH CONSTRUCTION, PLASTIC PROTECTION COVER, POWDER COATED, GREY H16B下壳, 表面安装, 彩锌单扣, M32, 高结构, 带塑料保护盖, 灰色粉末喷涂	M32	-	-	
TI660163221-000	H16B HOUSING, SURFACE MOUNTED, METAL SINGLE LOCKING, 2PG21, HIGH CONSTRUCTION, PLASTIC PROTECTION COVER, POWDER COATED, GREY H16B下壳, 表面安装, 彩锌单扣, 2PG21, 高结构, 带塑料保护盖, 灰色粉末喷涂	PG21	PG21	-	
TI660163229-000	H16B HOUSING, SURFACE MOUNTED, METAL SINGLE LOCKING, 2PG29, HIGH CONSTRUCTION, PLASTIC PROTECTION COVER, POWDER COATED, GREY H16B下壳, 表面安装, 彩锌单扣, 2PG29, 高结构, 带塑料保护盖, 灰色粉末喷涂	PG29	PG29	-	
TI660163232-000	H16B HOUSING, SURFACE MOUNTED, METAL SINGLE LOCKING, 2M32, HIGH CONSTRUCTION, PLASTIC PROTECTION COVER, POWDER COATED, GREY H16B下壳, 表面安装, 彩锌单扣, 2M32, 高结构, 带塑料保护盖, 灰色粉末喷涂	M32	M32	-	
TI660160932-000	H16B HOUSING, SURFACE MOUNTED, METAL SINGLE LOCKING, SIDE ENTRY PG9, BOTTOM ENTRY M32, HIGH CONSTRUCTION, PLASTIC PROTECTION COVER, POWDER COATED, GREY / H16B下壳, 表面安装, 彩锌单扣, 侧出PG9, 底出M32, 高结构, 带塑料保护盖, 灰色粉末喷涂	PG9	-	M32	

THIS DRAWING IS A CONTROLLED DOCUMENT.

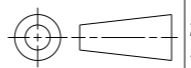
DIMENSIONS: mm	TOLERANCES UNLESS OTHERWISE SPECIFIED:
	0 PLC ±-
	1 PLC ±-
	2 PLC ±-
	3 PLC ±-
	4 PLC ±-
	ANGLES ±-
MATERIAL	FINISH
-	-
-	-

DWN	23JUN2015
DAVID LI	
CHK	23JUN2015
CHRIS WANG	
APVD	23JUN2015
XIANG XU	
PRODUCT SPEC	108-137013
APPLICATION SPEC	114-137013
WEIGHT	-
CUSTOMER DRAWING	

STE TE Connectivity

NAME: H16B-SDRHM-LB-PG/M

SIZE	CAGE CODE	DRAWING NO	RESTRICTED TO
A3	-	©-TI66016XXXXX00	-

SCALE: 1:2 SHEET: 3 OF 3 REV: B