

CZT3904 NPN
CZT3906 PNP

**SURFACE MOUNT SILICON
COMPLEMENTARY TRANSISTORS**



SOT-223 CASE



www.centrasemi.com

DESCRIPTION:

The CENTRAL SEMICONDUCTOR CZT3904 and CZT3906 are complementary silicon transistors manufactured by the epitaxial planar process, epoxy molded in a surface mount package, designed for small signal general purpose and switching applications.

MARKING: FULL PART NUMBER

MAXIMUM RATINGS: ($T_A=25^\circ\text{C}$)

Collector-Base Voltage
Collector-Emitter Voltage
Emitter-Base Voltage
Continuous Collector Current
Power Dissipation
Operating and Storage Junction Temperature
Thermal Resistance

SYMBOL	CZT3904	CZT3906	UNITS
V_{CBO}	60	40	V
V_{CEO}	40	40	V
V_{EBO}	6.0	5.0	V
I_C	200		mA
P_D	2.0		W
T_J, T_{stg}	-65 to +150		$^\circ\text{C}$
Θ_{JA}	62.5		$^\circ\text{C/W}$

ELECTRICAL CHARACTERISTICS: ($T_A=25^\circ\text{C}$ unless otherwise noted)

SYMBOL	TEST CONDITIONS	CZT3904		CZT3906		UNITS
		MIN	MAX	MIN	MAX	
I_{CEV}	$V_{CE}=30V, V_{EB}=3.0V$	-	50	-	50	nA
BV_{CBO}	$I_C=10\mu\text{A}$	60	-	40	-	V
BV_{CEO}	$I_C=1.0\text{mA}$	40	-	40	-	V
BV_{EBO}	$I_E=10\mu\text{A}$	6.0	-	5.0	-	V
$V_{CE(SAT)}$	$I_C=10\text{mA}, I_B=1.0\text{mA}$	-	0.20	-	0.25	V
$V_{CE(SAT)}$	$I_C=50\text{mA}, I_B=5.0\text{mA}$	-	0.30	-	0.40	V
$V_{BE(SAT)}$	$I_C=10\text{mA}, I_B=1.0\text{mA}$	0.65	0.85	0.65	0.85	V
$V_{BE(SAT)}$	$I_C=50\text{mA}, I_B=5.0\text{mA}$	-	0.95	-	0.95	V
h_{FE}	$V_{CE}=1.0V, I_C=0.1\text{mA}$	40	-	60	-	
h_{FE}	$V_{CE}=1.0V, I_C=1.0\text{mA}$	70	-	80	-	
h_{FE}	$V_{CE}=1.0V, I_C=10\text{mA}$	100	300	100	300	
h_{FE}	$V_{CE}=1.0V, I_C=50\text{mA}$	60	-	60	-	
h_{FE}	$V_{CE}=1.0V, I_C=100\text{mA}$	30	-	30	-	
f_T	$V_{CE}=20V, I_C=10\text{mA}, f=100\text{MHz}$	300	-	250	-	MHz
C_{ob}	$V_{CB}=5.0V, I_E=0, f=1.0\text{MHz}$	-	4.0	-	4.5	pF
C_{ib}	$V_{BE}=0.5V, I_C=0, f=1.0\text{MHz}$	-	12	-	12	pF
h_{ie}	$V_{CE}=10V, I_C=1.0\text{mA}, f=1.0\text{kHz}$	1.0	10	2.0	12	k Ω

CZT3904 NPN
CZT3906 PNP

**SURFACE MOUNT SILICON
COMPLEMENTARY TRANSISTORS**



ELECTRICAL CHARACTERISTICS - Continued: ($T_A=25^\circ\text{C}$)

SYMBOL	TEST CONDITIONS	CZT3904		CZT3906		UNITS
		MIN	MAX	MIN	MAX	
h_{re}	$V_{CE}=10\text{V}, I_C=1.0\text{mA}, f=1.0\text{kHz}$	0.5	8.0	0.1	10	$\times 10^{-4}$
h_{fe}	$V_{CE}=10\text{V}, I_C=1.0\text{mA}, f=1.0\text{kHz}$	100	400	100	400	
h_{oe}	$V_{CE}=10\text{V}, I_C=1.0\text{mA}, f=1.0\text{kHz}$	1.0	40	3.0	60	μS
NF	$V_{CE}=5.0\text{V}, I_C=100\mu\text{A}, R_S=1.0\text{k}\Omega$ $f=10\text{Hz}$ to 15.7kHz	-	5.0	-	4.0	dB
t_d	$V_{CC}=3.0\text{V}, V_{BE}=0.5\text{V}, I_C=10\text{mA}, I_{B1}=1.0\text{mA}$	-	35	-	35	ns
t_r	$V_{CC}=3.0\text{V}, V_{BE}=0.5\text{V}, I_C=10\text{mA}, I_{B1}=1.0\text{mA}$	-	35	-	35	ns
t_s	$V_{CC}=3.0\text{V}, I_C=10\text{mA}, I_{B1}=I_{B2}=1.0\text{mA}$	-	170	-	170	ns
t_f	$V_{CC}=3.0\text{V}, I_C=10\text{mA}, I_{B1}=I_{B2}=1.0\text{mA}$	-	80	-	80	ns

SOT-223 CASE - MECHANICAL OUTLINE

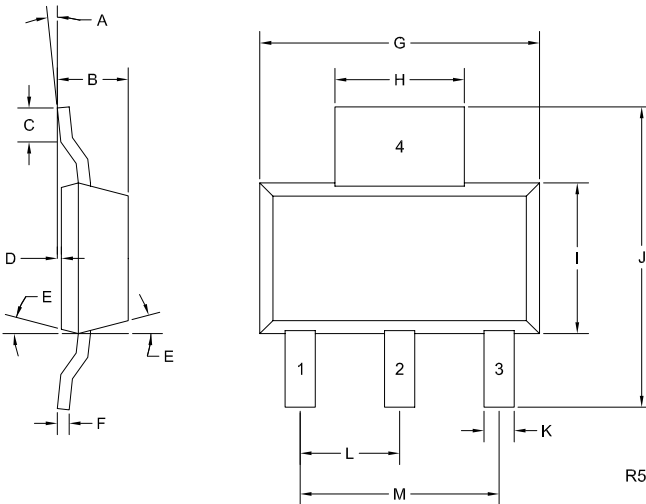

SYMBOL	DIMENSIONS			
	INCHES		MILLIMETERS	
	MIN	MAX	MIN	MAX
A	0°	10°	0°	10°
B	0.059	0.071	1.50	1.80
C	0.018	---	0.45	---
D	0.000	0.004	0.00	0.10
E	10°		10°	
F	0.009	0.014	0.23	0.35
G	0.248	0.270	6.30	6.85
H	0.114	0.122	2.90	3.10
I	0.130	0.146	3.30	3.70
J	0.264	0.287	6.70	7.30
K	0.024	0.033	0.60	0.85
L	0.091		2.30	
M	0.181		4.60	

SOT-223 (REV: R5)

LEAD CODE:

- 1) Base
- 2) Collector
- 3) Emitter
- 4) Collector

MARKING:

FULL PART NUMBER

OUTSTANDING SUPPORT AND SUPERIOR SERVICES



PRODUCT SUPPORT

Central's operations team provides the highest level of support to insure product is delivered on-time.

- Supply management (Customer portals)
- Inventory bonding
- Consolidated shipping options
- Custom bar coding for shipments
- Custom product packing

DESIGNER SUPPORT/SERVICES

Central's applications engineering team is ready to discuss your design challenges. Just ask.

- Free quick ship samples (2nd day air)
- Online technical data and parametric search
- SPICE models
- Custom electrical curves
- Environmental regulation compliance
- Customer specific screening
- Up-screening capabilities
- Special wafer diffusions
- PbSn plating options
- Package details
- Application notes
- Application and design sample kits
- Custom product and package development

REQUESTING PRODUCT PLATING

1. If requesting Tin/Lead plated devices, add the suffix "TIN/LEAD" to the part number when ordering (example: 2N2222A TIN/LEAD).
2. If requesting Lead (Pb) Free plated devices, add the suffix "PBFREE" to the part number when ordering (example: 2N2222A PBFREE).

CONTACT US

Corporate Headquarters & Customer Support Team

Central Semiconductor Corp.
145 Adams Avenue
Hauppauge, NY 11788 USA
Main Tel: (631) 435-1110
Main Fax: (631) 435-1824
Support Team Fax: (631) 435-3388
www.centrasemi.com

Worldwide Field Representatives:
www.centrasemi.com/wwreps

Worldwide Distributors:
www.centrasemi.com/wwdistributors

For the latest version of Central Semiconductor's **LIMITATIONS AND DAMAGES DISCLAIMER**, which is part of Central's Standard Terms and Conditions of sale, visit: www.centrasemi.com/terms