

Dual low voltage power amplifier

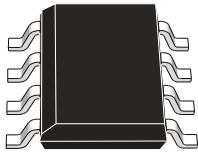

SO8

Features

- Supply voltage down to 1.8 V
- Low crossover distortion
- Low quiescent current
- Bridge or stereo configuration

Description

The **TDA2822D** is a monolithic integrated circuit in 8 lead (SO-8) package. It is intended for use as a dual audio power amplifier in portable cassette players, radios and CD players.

Product status link
TDA2822D
Ordering information
TDA2822D013TR

1 Application circuit

Figure 1. Application circuit

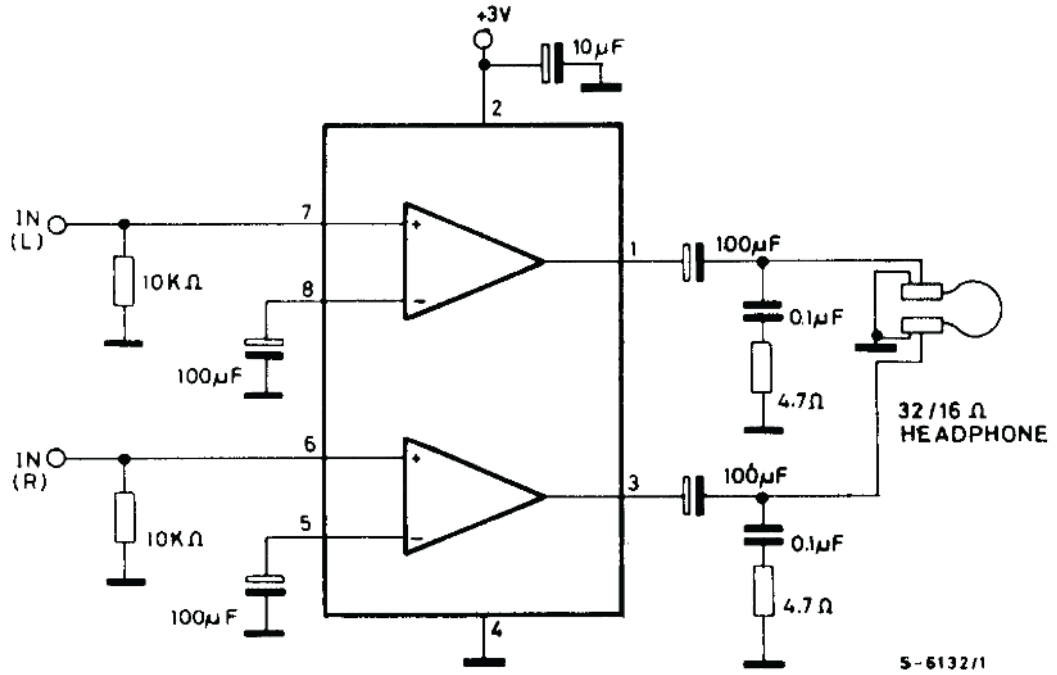

Figure 2. Stereo application and test circuit

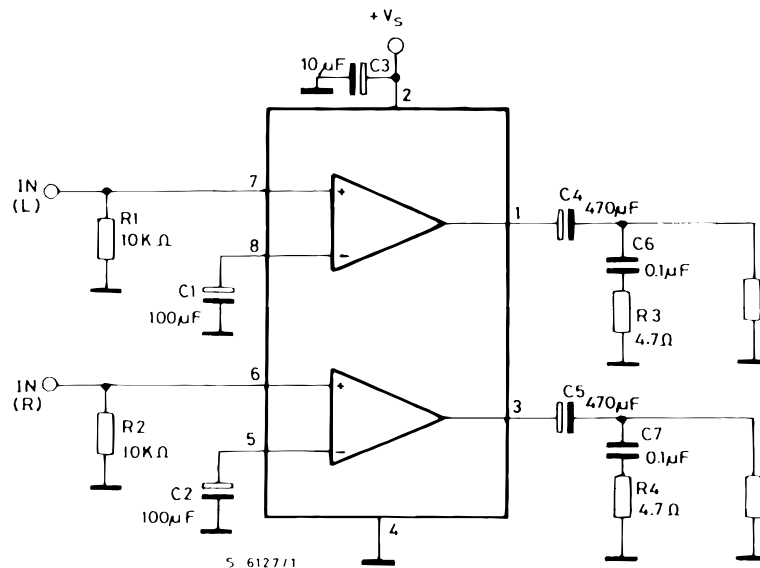
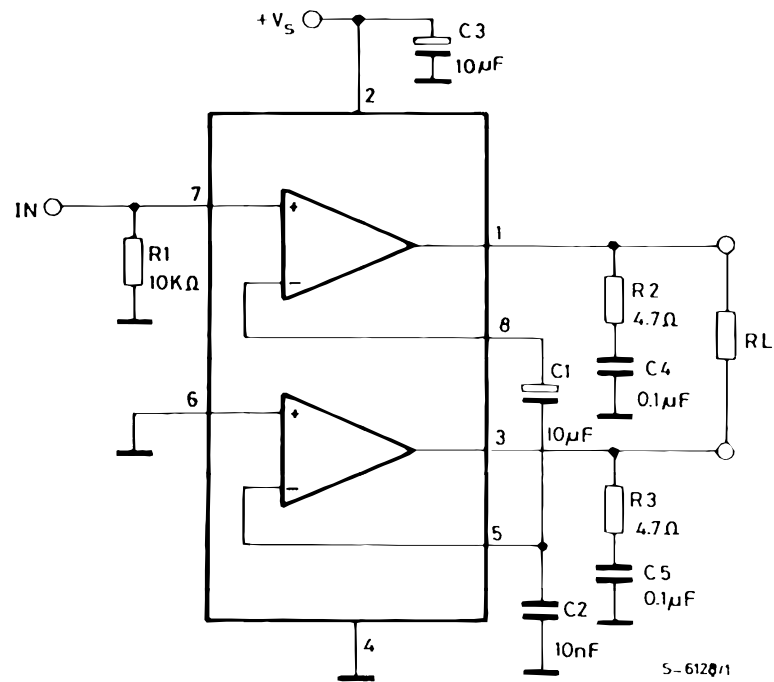
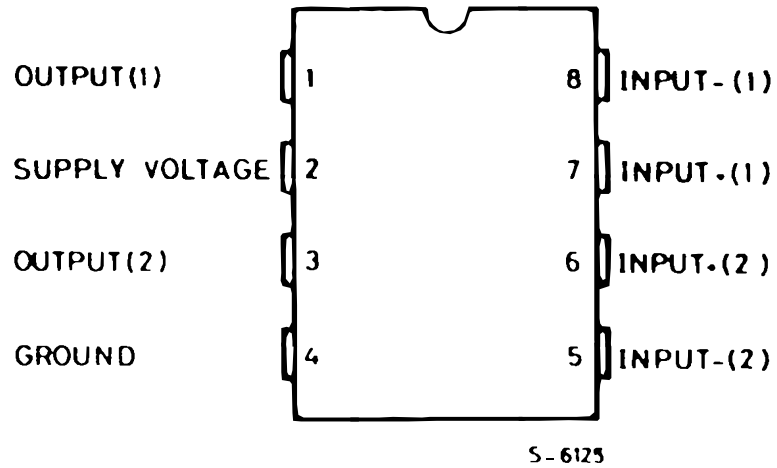

Figure 3. Bridge application and test circuit



2 Pin connection

Figure 4. Pin connection



3 Absolute maximum ratings

Table 1. Absolute maximum ratings

Symbol	Parameter	Value	Unit
V_S	Supply voltage	15	V
I_O	Peak output	1	A
P_{tot}	Total power dissipation $T_{amb} = 50\text{ °C}$	0.5	W
T_{stg}	Storage and junction temperature	-40 to 150	°C
T_j			

Table 2. Thermal data

Symbol	Description	Value	Unit
$R_{thj-amb}$	Thermal resistance junction-ambient max.	200	°C/W

4 Electrical characteristics

($V_S = 6\text{ V}$; $T_{amb} = 25\text{ °C}$, unless otherwise specified.
 STEREO (see Figure 2. Stereo application and test circuit).

Table 3. Electrical characteristics (stereo)

Symbol	Parameter	Test conditions	Min.	Typ.	Max.	Unit	
V_S	Supply voltage		1.8		15	V	
I_d	Total quiescent drain current				15	mA	
V_O	Quiescent output voltage			2.7		V	
		$V_S = 3\text{ V}$		1.2		V	
I_b	Input bias current			100		nA	
P_O	Output power (each channel) ($f = 1\text{ kHz}$, $d = 10\%$)	$R_L = 32\ \Omega$	$V_S = 9\text{ V}$	300		mW	
			$V_S = 6\text{ V}$	120			
			$V_S = 4.5\text{ V}$	60			
			$V_S = 3\text{ V}$	20			
			$V_S = 2\text{ V}$	5			
		$R_L = 16\ \Omega$	$V_S = 6\text{ V}$	170	220		mW
		$R_L = 8\ \Omega$	$V_S = 6\text{ V}$	300	380		mW
		$R_L = 4\ \Omega$	$V_S = 4.5\text{ V}$		320		mW
$V_S = 3\text{ V}$		110					
d	Distortion	$R_L = 32\ \Omega$	$P_O = 40\text{ mW}$		0.2	%	
		$R_L = 16\ \Omega$	$P_O = 75\text{ mW}$		0.2	%	
		$R_L = 8\ \Omega$	$P_O = 150\text{ mW}$		0.2	%	
G_V	Closed loop voltage gain	$f = 1\text{ kHz}$	36	39	41	dB	
ΔG_V	Channel balance				1	dB	
R_i	Input resistance	$f = 1\text{ kHz}$	100			k Ω	
e_N	Total input noise	$R_S = 10\text{ k}\Omega$, B = curve A		2		μV	
		$R_S = 10\text{ k}\Omega$, B = 22 Hz to 22 kHz		2.5		μV	
SVR	Supply voltage rejection	$f = 100\text{ Hz}$, $C_1 = C_2 = 100\text{ F}$	24	30		dB	
C_s	Channel separation	$f = 1\text{ kHz}$		50		dB	

Bridge (see Figure 3. Bridge application and test circuit).

Table 4. Electrical characteristics (bridge)

Symbol	Parameter	Test conditions		Min.	Typ.	Max.	Unit
V_S	Supply voltage			1.8		15	V
I_d	Total quiescent drain current		$R_L = \infty$			15	mA
V_{OS}	Output offset voltage between the outputs		$R_L = 8 \Omega$			± 80	mV
I_b	Input bias current				100		nA
P_O	Output power (f = 1 kHz, d = 10%)	$R_L = 32 \Omega$	$V_S = 9 V$	1000			mW
			$V_S = 6 V$	320	400		
			$V_S = 4.5 V$		200		
			$V_S = 3 V$	50	65		
			$V_S = 2 V$		8		
		$R_L = 16 \Omega$	$V_S = 6 V$		800		mW
			$V_S = 3 V$		120		
		$R_L = 8 \Omega$	$V_S = 4.5 V$		700		mW
			$V_S = 3 V$		220		
		$R_L = 4 \Omega$	$V_S = 3 V$		350		mW
$V_S = 2 V$			80				
d	Distortion	$R_L = 8 \Omega$	$P_O = 0.5 mW, f = 1 kHz$		0.2		%
G_V	Closed loop voltage gain		f = 1 kHz		39		dB
R_i	Input resistance		f = 1 kHz	100			k Ω
e_N	Total input noise		$R_S = 10 k\Omega, B = \text{curve A}$		2.5		μV
			$R_S = 10 k\Omega, B = 22 Hz \text{ to } 22 kHz$		3		
SVR	Supply voltage rejection		f = 100 Hz		40		dB
B	Power bandwidth (-3 dB)		$R_L = 8 k\Omega, P_O = 1 W$		120		kHz

Figure 5. Supply voltage rejection vs. frequency

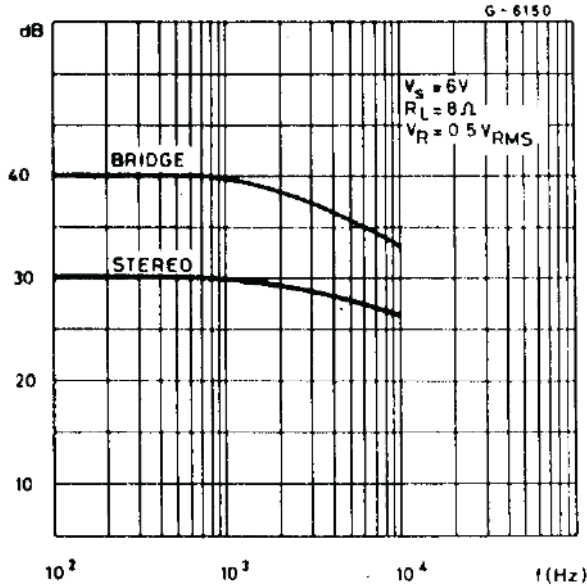

Figure 6. Output power vs. supply voltage (THD= 10%, f=1 kHz stereo)

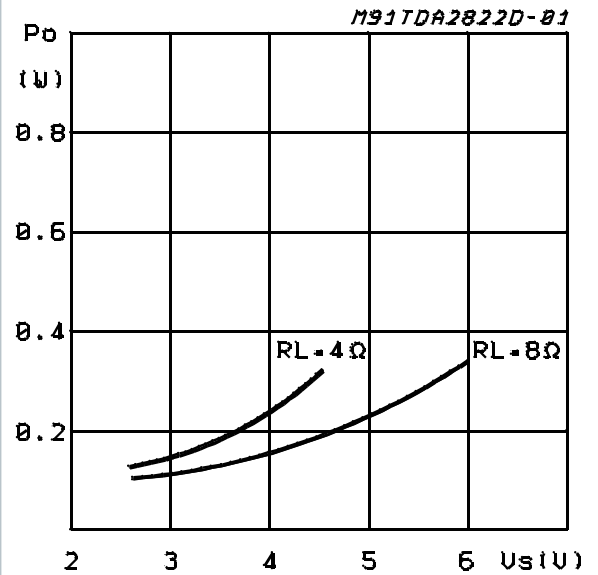

Figure 7. Total power dissipation vs. output power (bridge, RL=8 Ω)

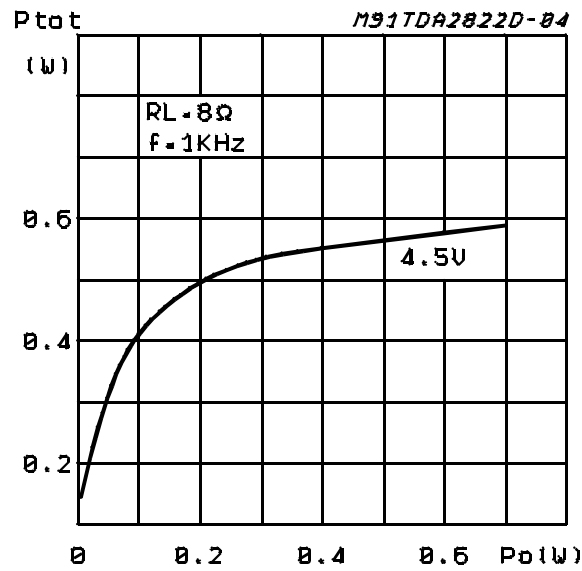
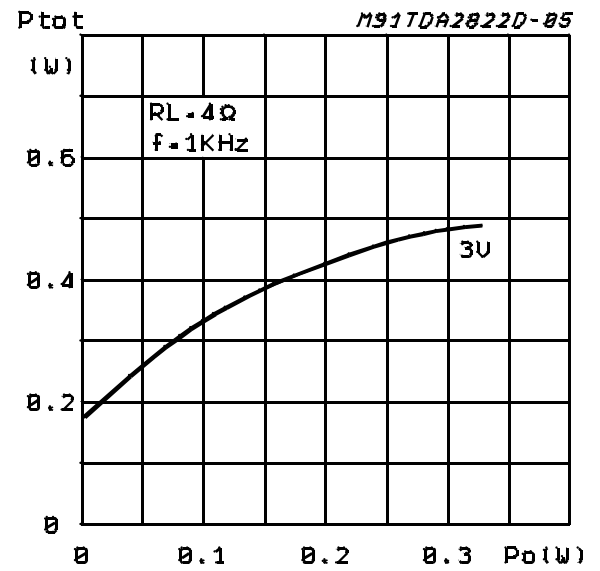

Figure 8. Total power dissipation vs. output power (bridge, RL=4 Ω)



5 Package information

In order to meet environmental requirements, ST offers these devices in different grades of **ECOPACK** packages, depending on their level of environmental compliance. ECOPACK specifications, grade definitions and product status are available at: www.st.com. ECOPACK is an ST trademark.

5.1 SO8 package information

Figure 9. SO8 package outline

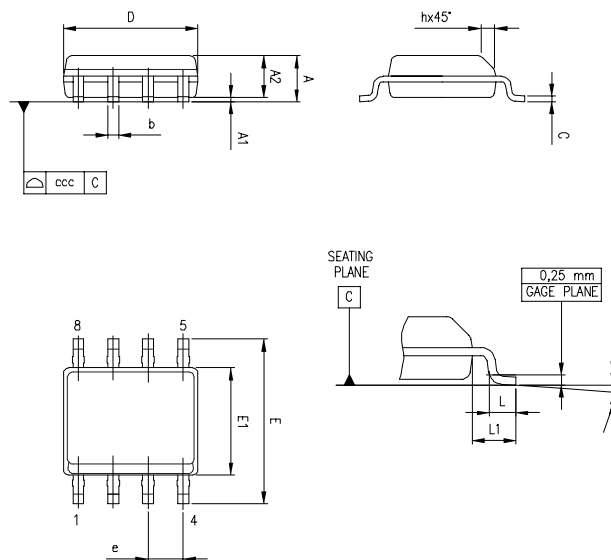

Table 5. SO-8 mechanical data

Dim.	mm			Inches		
	Min.	Typ.	Max.	Min.	Typ.	Max.
A			1.75			0.069
A1	0.1		0.25	0.004		0.01
A2	1.25			0.049		
b	0.28		0.48	0.011		0.019
c	0.17		0.23	0.007		0.01
D	4.8	4.9	5	0.189	0.193	0.197
E	5.8	6	6.2	0.228	0.236	0.244
E1	3.8	3.9	4	0.15	0.154	0.157
e		1.27			0.05	
h	0.25		0.5	0.01		0.02
L	0.4		1.27	0.016		0.05
L1		1.04			0.04	
k			8 °			8 °
ccc			0.1			0.004

Revision history

Table 6. Document revision history

Date	Version	Changes
05-Sep-2003	1	No history because of migration.
19-Sep-2016	2	
28-Aug-2020	3	Updated the ordering information table in cover page.

Contents

1	Application circuit	2
2	Pin connection	4
3	Absolute maximum ratings	5
4	Electrical characteristics	6
5	Package information	9
5.1	SO-8 package information	9
	Revision history	10

IMPORTANT NOTICE – PLEASE READ CAREFULLY

STMicroelectronics NV and its subsidiaries (“ST”) reserve the right to make changes, corrections, enhancements, modifications, and improvements to ST products and/or to this document at any time without notice. Purchasers should obtain the latest relevant information on ST products before placing orders. ST products are sold pursuant to ST’s terms and conditions of sale in place at the time of order acknowledgement.

Purchasers are solely responsible for the choice, selection, and use of ST products and ST assumes no liability for application assistance or the design of Purchasers’ products.

No license, express or implied, to any intellectual property right is granted by ST herein.

Resale of ST products with provisions different from the information set forth herein shall void any warranty granted by ST for such product.

ST and the ST logo are trademarks of ST. For additional information about ST trademarks, please refer to www.st.com/trademarks. All other product or service names are the property of their respective owners.

Information in this document supersedes and replaces information previously supplied in any prior versions of this document.

© 2020 STMicroelectronics – All rights reserved