

NOTES:

1. ROHS COMPLIANT
2. HEADER: PHENOLIC WITH FLAMMABILITY RATING UL 94V-0 OR BETTER.
3. STORAGE TEMPERATURE: -20°C TO +125°C
4. COMPLIANCE TO J-STD:
 - A. J-STD-002: SOLDERABILITY AT 245°C REFLOW PROFILE
 - B. J-STD-020: LEVEL 1, NO MOISTURE SENSITIVE
 - C. J-STD-075: R7, 245°C MAXIMUM THROUGH REFLOW SOLDER
5. TO ORDER TAPE & REEL PACKAGING ADD A "T" SUFFIX TO THE PART NUMBER(i.e E2032FNL BECOMES E2032FNLT).

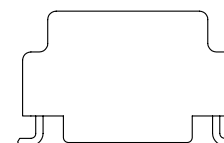
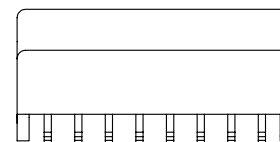
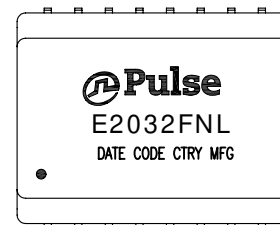

FINAL OUTLINE

© Copyright, 2014. Pulse Electronics Corp. All rights reserved. Pulse confidential & proprietary. (06/11/14)

PRODUCT DESCRIPTION	TLA DRAWING	PS DRAWING	SHEET	PART NO.	DATASHEET REV.
XFMR,SIN,10D,1:1,SM,TU	E2032FNL-10	PS-2755.001-A	1 OF 3	E2032FNL	A

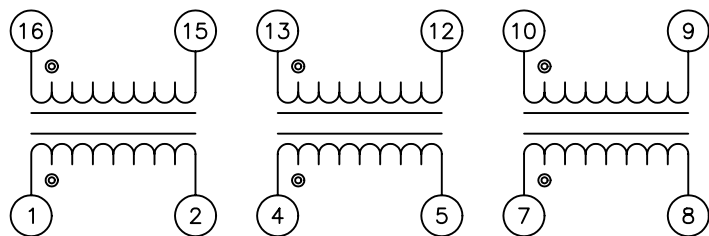

SCHEMATIC

ELECTRICAL CHARACTERISTICS AT +25°C UNLESS OTHER SPECIFIED

ITEM	SPECIFICATIONS	TEST CONDITIONS	SPEC
1	OPERATING TEMPERATURE		0°C ~ +70°C
2	POLARITY		PER SCHEMATIC
3	LP (14-16)	10KHz/0.005VRMS	67uH MIN
4	HIPOT PRI TO SEC	1500VAC/1MIN	
5	TURN RATIO	10KHz 10mV	1:1 ±5%
6	DCR		0.3 OHMS MAX
7	LEAKAGE INDUCTANCE	1MHz MIN	0.25uH MIN
8	CAPACITANCE WINDING TO WINDING	140KHz	10pF MAX

© Copyright, 2014. Pulse Electronics Corp. All rights reserved. Pulse confidential & proprietary. (06/11/14)

PRODUCT DESCRIPTION	TLA DRAWING	PS DRAWING	SHEET	PART NO.	DATASHEET REV.
XFMR,SIN,10D,1:1,SM,TU	E2032FNL-10	PS-2755.001-A	2 OF 3	E2032FNL	A

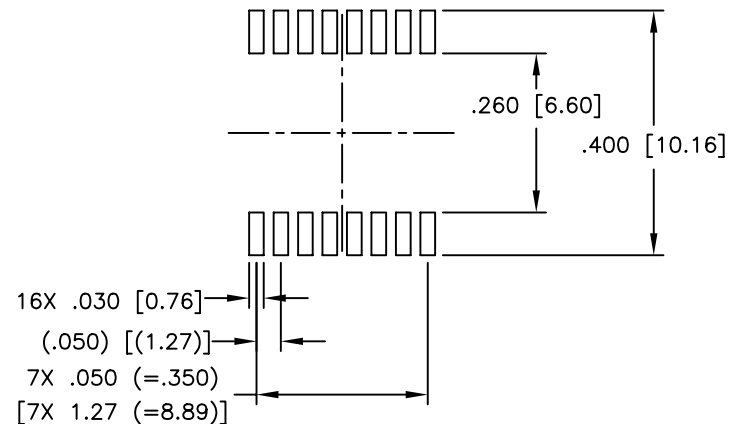
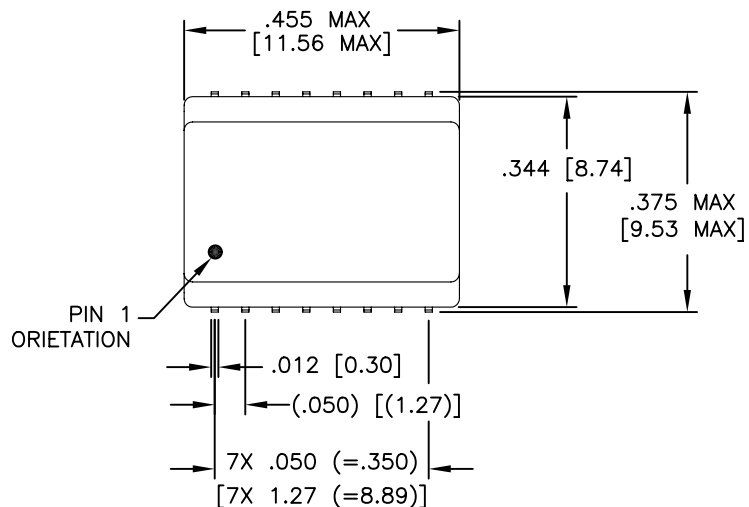

SUGGESTED LAND PATTERN

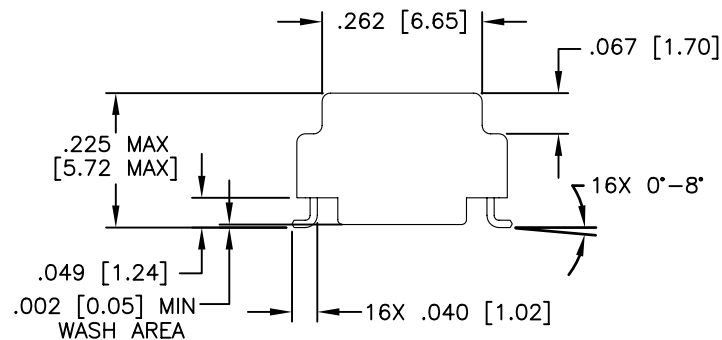
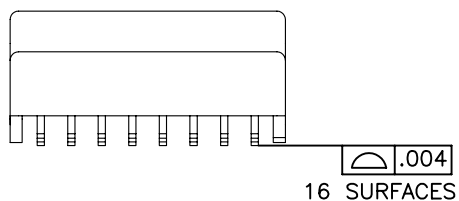

DIMENSIONS ARE IN INCHES [MILLIMETERS] WITH THE FOLLOWING TOLERANCES: [MILLIMETERS] ARE FOR REFERENCE ONLY.
.XX= ±.01 [±0.25]
.XXX= ±.005 [±0.13]

© Copyright, 2014. Pulse Electronics Corp. All rights reserved. Pulse confidential & proprietary. (06/11/14)

PRODUCT DESCRIPTION	TLA DRAWING	PS DRAWING	SHEET	PART NO.	DATASHEET REV.
XFMR,SIN,10D,1:1,SM,TU	E2032FNL-10	PS-2755.001-A	3 OF 3	E2032FNL	A