

NO. OF CIRCUITS	DIM. "A"		DIM. "B"		ASSEMBLY MATERIAL NO. (STANDARD)	ASSEMBLY MATERIAL NO. (-50 OPT)
	mm	in	mm	in		
02	17.9	.71	8.3	.33	386912302	386913502
03	26.2	1.03	16.5	.65	386912303	386913503
04	34.4	1.36	24.8	.98	386912304	386913504
05	42.7	1.68	33.0	1.30	386912305	386913505
06	50.9	2.01	41.3	1.63	386912306	386913506
07	59.2	2.33	49.5	1.95	386912307	386913507
08	67.4	2.66	57.8	2.28	386912308	386913508
09	75.7	2.98	66.0	2.60	386912309	386913509
10	83.9	3.31	74.3	2.93	386912310	386913510
11	92.2	3.63	82.6	3.25	386912311	386913511
12	100.5	3.96	90.8	3.58	386912312	386913512
13	108.7	4.28	99.1	3.90	386912313	386913513
14	117.0	4.61	107.3	4.23	386912314	386913514
15	125.2	4.93	115.6	4.55	386912315	386913515
16	133.5	5.26	123.8	4.88	386912316	386913516
17	141.7	5.58	132.1	5.20	386912317	386913517
18	150.0	5.91	140.3	5.53	386912318	386913518
19	158.2	6.23	148.6	5.85	386912319	386913519
20	166.5	6.56	156.8	6.18	386912320	386913520
21	174.8	6.88	165.1	6.50	386912321	386913521
22	183.0	7.21	173.4	6.83	386912322	386913522
23	191.3	7.53	181.6	7.15	386912323	386913523
24	199.5	7.86	189.9	7.48	386912324	386913524
25	207.8	8.18	198.1	7.80	386912325	386913525
26	216.0	8.51	206.4	8.13	386912326	386913526
27	224.3	8.83	214.6	8.45	386912327	386913527
28	232.5	9.16	222.9	8.78	386912328	386913528
29	240.8	9.48	231.1	9.10	386912329	386913529
30	249.0	9.81	239.4	9.43	386912330	386913530
31	257.3	10.13	247.7	9.75	386912331	386913531
32	265.6	10.46	255.9	10.08	386912332	386913532

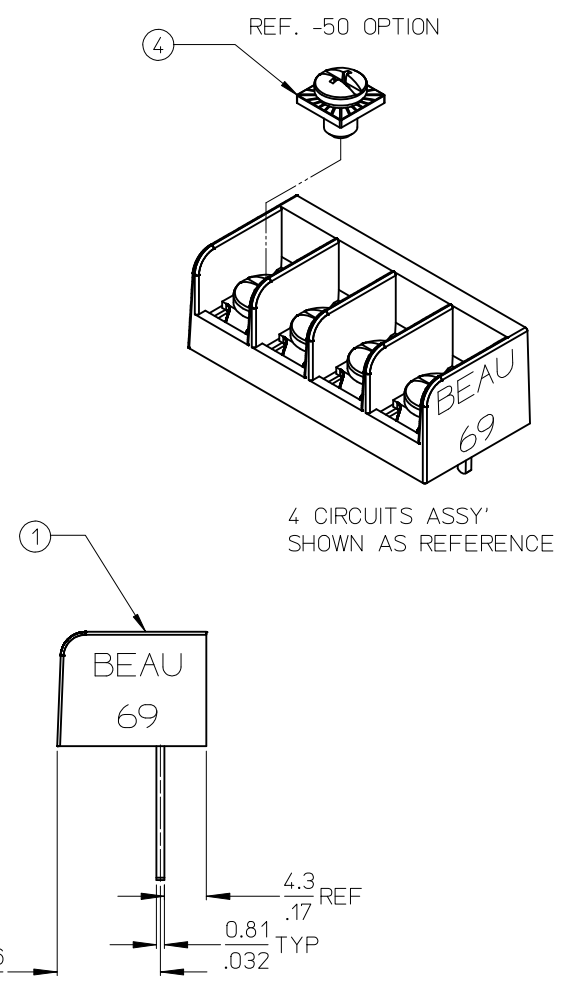
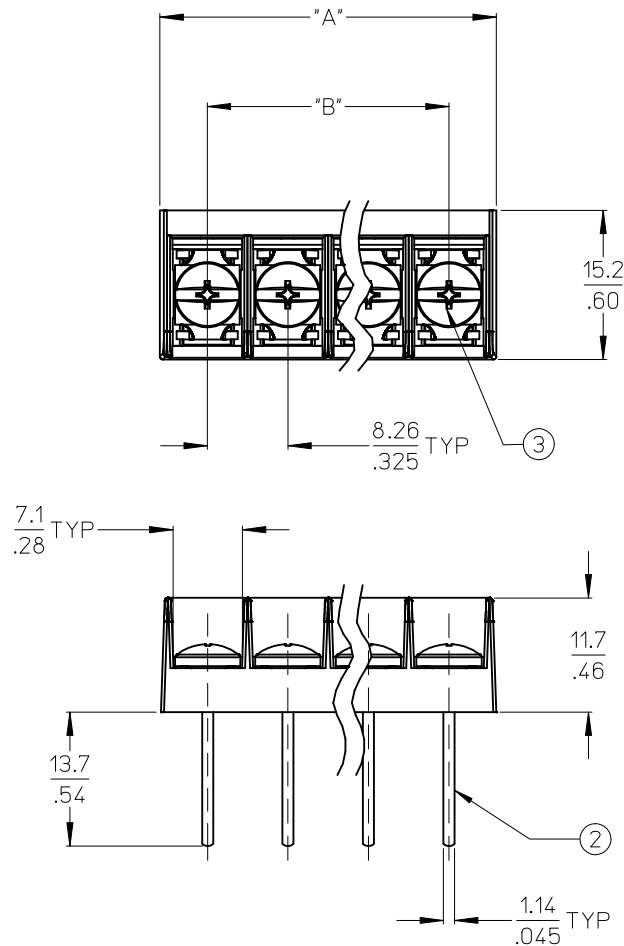

- NOTES:  
 1. MATERIAL: SEE TABLE  
 2. FINISHES: SEE TABLE.  
 3. "XX" REFERS TO THE QUANTITY OF CIRCUITS.  
 4. ROHS COMPLIANT.

ITEM	QTY.	DESCRIPTION	MATERIAL NO.	ENGINEERING NO.
4	XX	SCREW #6-32X.155 PAN PHSLZN/BR/STEEL -50	STEEL	ZN, CLEAR CHROMATE
3	XX	SCREW #6-32X.160 PAN PHSLNI/BRASS (STD)	BRASS	NICKEL PLATE
2	XX	TERMINAL, PC	BRASS	TIN PLATE
1	1	INSULATOR	POLYESTER (PBT)	BLACK

RELEASED  
 EC NO: IPG2012-0967  
 DRAWN: JENC INAS 2012/05/25  
 CHKD: JMACNEIL 2012/05/31  
 APPR: JMACNEIL 2012/06/01

QUALITY SYMBOLS  
 ▼=0  
 ▽=0

GENERAL TOLERANCES (UNLESS SPECIFIED)	
mm	INCH
4 PLACES ± ---	± ---
3 PLACES ± ---	± .005
2 PLACES ± 0.13	± .01
1 PLACE ± 0.3	± ---
ANGULAR ± 2°	

DRAFT WHERE APPLICABLE  
 MUST REMAIN WITHIN DIMENSIONS

DIMENSION STYLE  
**MM/IN**

SCALE  
**2:1**

DESIGN UNITS  
**INCH**

THIRD ANGLE PROJECTION

DRAWN BY  
 AHIDALGO

DATE  
 2007/04/02

CHECKED BY  
 JENCINAS

DATE  
 2007/04/02

APPROVED BY  
 JMACNEIL

DATE  
 2012/06/01

MATERIAL NO.  
**SEE CHART**

TITLE  
**8.26/.325 SR TRI-BARRIER TERMINAL STRIP -C -W -50**

**MOLEX INCORPORATED**

DOCUMENT NO.  
**SD-38691-002**

SHEET NO.  
**1 OF 1**

THIS DRAWING CONTAINS INFORMATION THAT IS PROPRIETARY TO MOLEX INCORPORATED AND SHOULD NOT BE USED WITHOUT WRITTEN PERMISSION