

NPC-1220 Series

Medium Pressure Sensors



Applications

- Industrial automation
- Air flow monitors
- Process control
- Medical equipment
- Underground cable leak detection

Features

- 50 mV full scale output (FSO)
- $\pm 0.1\%$ accuracy
- Interchangeable
- Temperature compensated 32°F to 140°F (0°C to 60°C)
- PCB mountable package
- DIP package
- Solid state reliability
- Individual device traceability

NPC-1220 Specifications

Description

The NPC-1220 Series of solid state pressure sensors are designed to provide a cost effective solution for applications that require calibrated performance over a wide temperature range. Packaged in a dual-in-line configuration, the NPC-1220 Series is intended for printed circuit board mounting. Optional pressure port and lead configurations give superior flexibility in low profile applications where pressure connection orientation is critical.

The NPC-1220 Series is based on NovaSensor's advanced SenStable® piezoresistive sensing

technology. Silicon micromachining techniques are used to ion implant piezoresistive strain gages into a Wheatstone bridge configuration. The NPC-1220 Series offers the added advantage of superior temperature performance over the temperature compensated range of 32°F to 140°F (0°C to 60°C). A current set resistor is included to normalize the FSO for field interchangeability. Additionally, the NPC-1220 Series is available in pressure ranges from 0 psi to 5 psi (0 bar to 0.34 bar) through 0 psi to 100 psi (0 bar to 6.89 bar). Please contact NovaSensor or other pressure ranges.

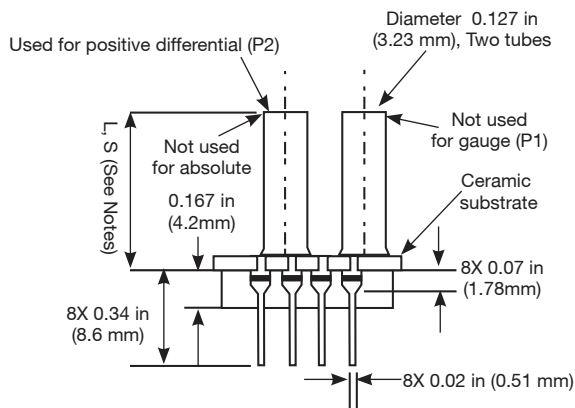
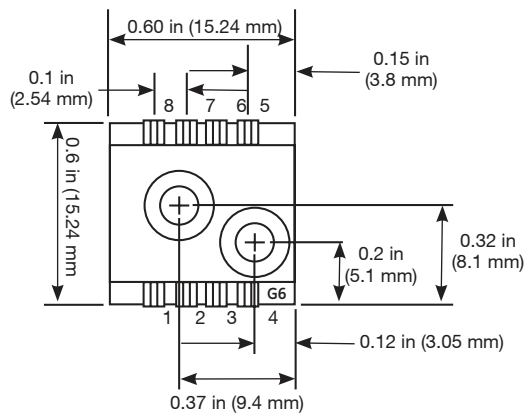

NPC-1220 Series package diagram

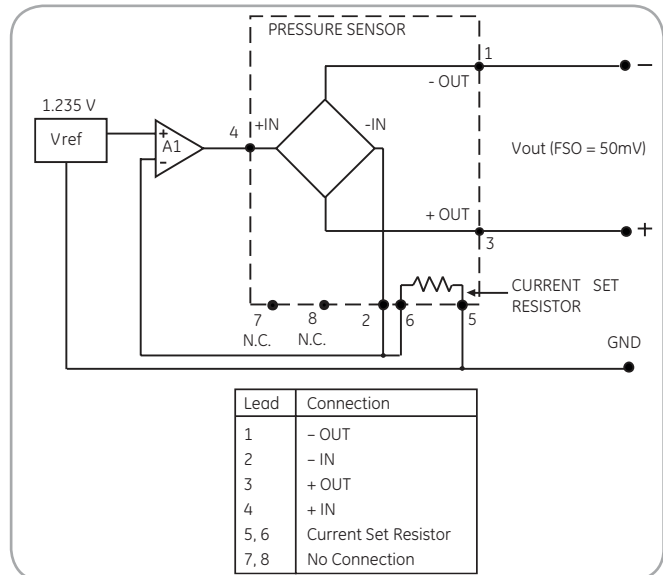

NPC-1220 Series schematic diagram

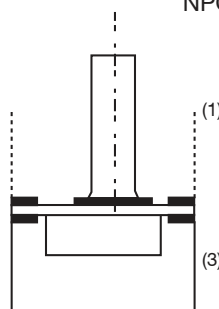

1. Tube length; L = 0.490, S=0.325, N = No tube.
2. Lead pins can be in either the same or the opposite direction of the pressure tube. Option (1) has the leads in the "Up" position, the same direction as the tube. Option (3) has the leads in the "Down" position, the opposite direction of the tube.
3. Gauge and differential pressure devices are calibrated by applying pressure to the positive differential port (P2) and venting to atmosphere the reference port (P1). Absolute pressure devices use only P1 to apply vacuum or pressure.

NPC-1220 Specifications

Pressure Ranges

- Gauge and differential: 5, 15, 30, 50 and 100 psi (0.34, 1.03, 2.06, 3.44 and 6.89 bar)
- Absolute: 15, 30, 50 and 100 psi (1, 2, 3.4 and 7 bar); 5 psi (0.34 bar)— call NovaSensor

Parameter	Value	Units	Notes
Environmental			
Temperature Range			
Operating	-40° to 257°	°F	(-40°C to 125°C)
Compensated	32° to 140°	°F	(0°C to 60°C)
Storage	-67°F to 302°	°F	(-55°C to 150 °C)
Mechanical			
Weight	0.005	lb	(2.5 g)
Media Compatibility	Compatible with exposed materials		7
Positive differential and gauge ports	Compatible with exposed materials		
Absolute. Negative differential ports	Dry gases only		

Warranty

NovaSensor warrants its products against defects in material and workmanship for 12 months from the date of shipment . Products not subjected to misuse will be repaired or replaced. NovaSensor reserves the right to make changes without further notice to any products herein. NovaSensor makes no warranty, representation or guarantee regarding the suitability of its products for any particular application. NovaSensor does not assume any liability arising out of the application or use of any product or circuit and specifically disclaims, and all liability without limitation, consequential or incidental damages. The foregoing warranties are exclusive and in lieu of all other warranties, whether written, oral, implied or statutory. No implied statutory warranty of merchantability or fitness for particular purpose shall apply.

Parameter	Units	Min.	Typical	Max.	Notes
Performance Parameters (1)					
FS Output (FSO)	mV	49.5	50	50.5	2, 3
Zero Pressure Output	mV	-2	—	2	3
Linearity	±%FSO	-0.1	—	0.1	4, 8
Pressure Hysteresis	±%FSO	-0.1	—	0.1	
Input Impedance	Ω	2500	4000	6000	
Output Impedance	Ω	4000	5000	6000	
Thermal Accuracy–Span	%FSO	-0.5	—	0.5	3, 5, 8
Thermal Accuracy–Zero	%FSO	-0.5	—	0.5	3, 5, 8
Temperature Coefficient–Resistance	%/°C	—	0.2	—	5
Thermal Hysteresis–Zero	%FSO	—	0.1	—	5
Maximum Pressure	Rated	—	—	3X	6

1. Ambient temperature = 77°F (25°C), unless otherwise noted. Gauge and differential pressure devices are calibrated by applying pressure to the positive pressure port (P2) and venting to atmosphere the reference port (P1).
2. Output span of unamplified sensor using the current set resistor and the circuit shown in the schematic drawing.
3. Compensation resistors are an integral part of the sensor package; no additional external resistors are required. Pins 7 and 8 must be kept open. The NPC-1220 is interchangeable only when used with the current set resistor shown in the schematic diagram.
4. Best fit straight line.
5. Temperature range 32°F to 140°F (0°C to 60°C), reference to 77°F (25°C).
6. 3X or 200 psi (13.78 bar) maximum, whichever is less.
7. Exposed materials are pyrex, ceramic, silicon, epoxy, RTV, and stainless steel..
8. 5 psi (0.34 bar) spec.:
 - Linearity: 0.25 ±%FSO
 - TC-span: 0.75 ±%FSO
 - TC-zero: 0.75 ±%FSO

NPC-1220 Specifications

Ordering Information

The code number to be ordered may be specified as follows:
NPC-1220

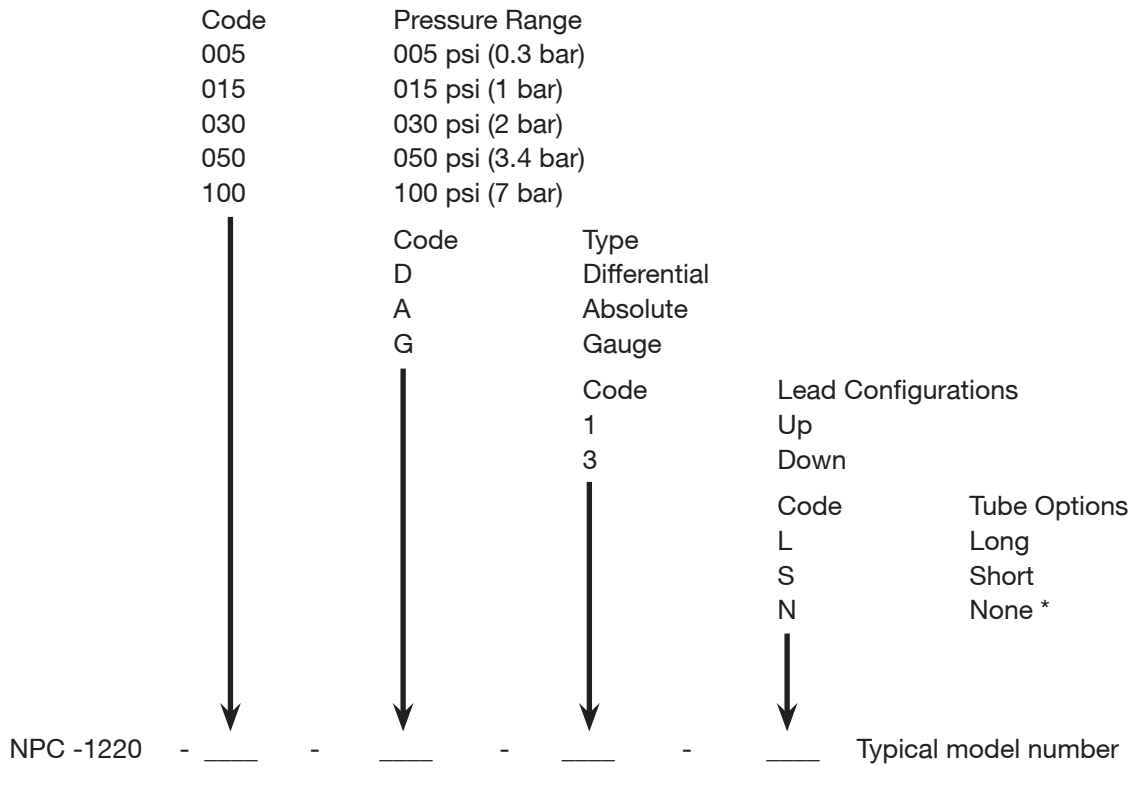

* Order NPC-1220-XXXG-XN in place of NPC-1220-XXXD-XN