

32K x 16 Static RAM

Features

- **High speed**
— $t_{AA} = 12, 15 \text{ ns}$
- **CMOS for optimum speed/power**
- **Low active power**
— 825 mW (max.)
- **Low CMOS standby power**
— 16.5 mW (max.)
- **Automatic power-down when deselected**
- **Independent control of upper and lower bits**
- **Available in lead-free and non-lead-free 44-pin TSOP II and 44-pin (400-mil) SOJ packages**

Functional Description

The CY7C1020B is a high-performance CMOS static RAM organized as 32,768 words by 16 bits. This device has an automatic power-down feature that significantly reduces power consumption when deselected.

Writing to the device is accomplished by taking Chip Enable (CE) and Write Enable (WE) inputs LOW. If Byte Low Enable (BLE) is LOW, then data from I/O pins (I/O₁ through I/O₈), is written into the location specified on the address pins (A₀ through A₁₄). If Byte High Enable (BHE) is LOW, then data from I/O pins (I/O₉ through I/O₁₆) is written into the location specified on the address pins (A₀ through A₁₄).

Reading from the device is accomplished by taking Chip Enable (CE) and Output Enable (OE) LOW while forcing the Write Enable (WE) HIGH. If Byte Low Enable (BLE) is LOW, then data from the memory location specified by the address pins will appear on I/O₁ to I/O₈. If Byte High Enable (BHE) is LOW, then data from memory will appear on I/O₉ to I/O₁₆. See the truth table at the back of this data sheet for a complete description of read and write modes.

The input/output pins (I/O₁ through I/O₁₆) are placed in a high-impedance state when the device is deselected (CE HIGH), the outputs are disabled (OE HIGH), the BHE and BLE are disabled (BHE, BLE HIGH), or during a write operation (CE LOW, and WE LOW).

The CY7C1020B is available in standard 44-pin TSOP Type II and 44-pin 400-mil-wide SOJ packages.

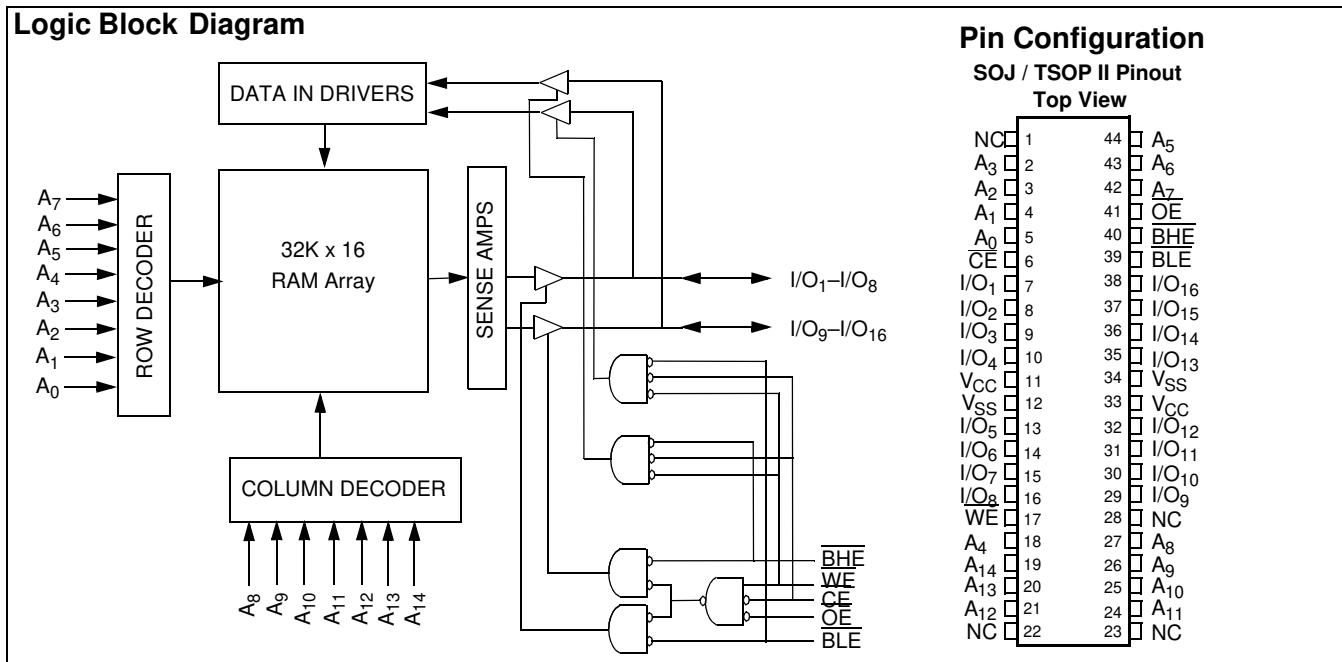

Selection Guide

	CY7C1020B-12	CY7C1020B-15
Maximum Access Time (ns)	12	15
Maximum Operating Current (mA)	140	130
Maximum CMOS Standby Current (mA)	3	3

Maximum Ratings

(Above which the useful life may be impaired. For user guidelines, not tested.)

Storage Temperature	-65°C to +150°C
Ambient Temperature with Power Applied.....	-55°C to +125°C
Supply Voltage on V _{CC} Relative to GND ^[1]	-0.5V to +7.0V
DC Voltage Applied to Outputs in High Z State ^[1]	-0.5V to V _{CC} + 0.5V
DC Input Voltage ^[1]	-0.5V to V _{CC} + 0.5V

Current into Outputs (LOW).....	20 mA
Static Discharge Voltage.....	>2001V (per MIL-STD-883, Method 3015)
Latch-Up Current.....	>200 mA

Operating Range

Range	Ambient Temperature ^[2]	V _{CC}
Commercial	0°C to +70°C	5V ± 10%

Electrical Characteristics Over the Operating Range

Parameter	Description	Test Conditions	CY7C1020B-12		CY7C1020B-15		Unit
			Min.	Max.	Min.	Max.	
V _{OH}	Output HIGH Voltage	V _{CC} = Min., I _{OH} = -4.0 mA	2.4		2.4		V
V _{OL}	Output LOW Voltage	V _{CC} = Min., I _{OL} = 8.0 mA		0.4		0.4	V
V _{IH}	Input HIGH Voltage		2.2	6.0	2.2	6.0	V
V _{IL}	Input LOW Voltage ^[1]		-0.5	0.8	-0.5	0.8	V
I _{Ix}	Input Leakage Current	GND ≤ V _I ≤ V _{CC}	-1	+1	-1	+1	μA
I _{OZ}	Output Leakage Current	GND ≤ V _I ≤ V _{CC} , Output Disabled	-1	+1	-1	+1	μA
I _{OS}	Output Short Circuit Current ^[3]	V _{CC} = Max., V _{OUT} = GND		-300		-300	mA
I _{CC}	V _{CC} Operating Supply Current	V _{CC} = Max., I _{OUT} = 0 mA, f = f _{MAX} = 1/t _{RC}		140		130	mA
I _{SB1}	Automatic CE Power-Down Current—TTL Inputs	Max. V _{CC} , $\overline{CE} \geq V_{IH}$, V _{IN} ≥ V _{IH} or V _{IN} ≤ V _{IL} , f = f _{MAX}		20		20	mA
I _{SB2}	Automatic CE Power-Down Current—CMOS Inputs	Max. V _{CC} , $\overline{CE} \geq V_{CC} - 0.3V$, V _{IN} ≥ V _{CC} - 0.3V, or V _{IN} ≤ 0.3V, f = 0		3		3	mA

Capacitance^[4]

Parameter	Description	Test Conditions	Max.	Unit
C _{IN}	Input Capacitance	T _A = 25°C, f = 1 MHz, V _{CC} = 5.0V	8	pF
C _{OUT}	Output Capacitance		8	pF

Thermal Resistance^[4]

Parameter	Description	Test Conditions	TSOP II Package	SOJ Package	Unit
θ _{JA}	Thermal Resistance (Junction to Ambient)	Still Air, soldered on a 3 × 4.5 inch, four-layer printed circuit board	50.55	56.31	°C/W
θ _{JC}	Thermal Resistance (Junction to Case)		15.8	32.9	°C/W

Notes:

1. V_{IL} (min.) = -2.0V for pulse durations of less than 20 ns.
2. T_A is the case temperature.
3. Not more than one output should be shorted at one time. Duration of the short circuit should not exceed 30 seconds.
4. Tested initially and after any design or process changes that may affect these parameters.

AC Test Loads and Waveforms

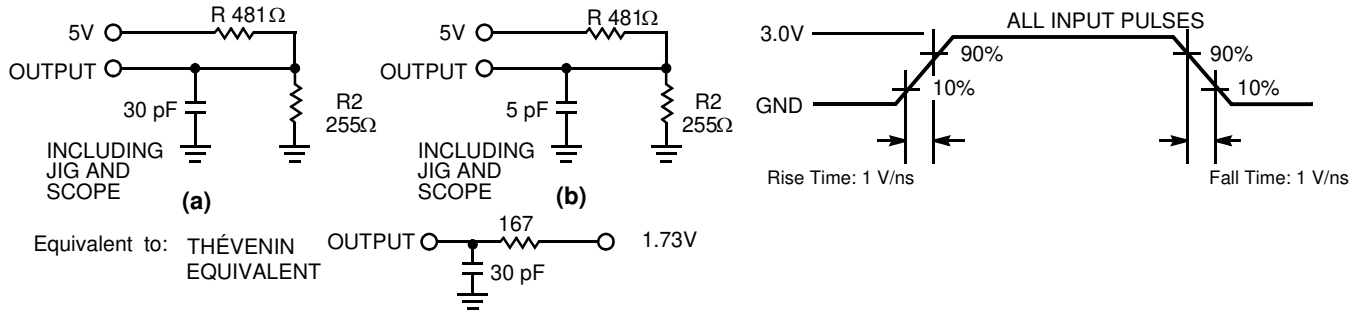

Switching Characteristics^[5] Over the Operating Range

Parameter	Description	CY7C1020B-12		CY7C1020B-15		Unit
		Min.	Max.	Min.	Max.	
Read Cycle						
t _{RC}	Read Cycle Time	12		15		ns
t _{AA}	Address to Data Valid		12		15	ns
t _{OHA}	Data Hold from Address Change	3		3		ns
t _{ACE}	\overline{CE} LOW to Data Valid		12		15	ns
t _{DOE}	\overline{OE} LOW to Data Valid		6		7	ns
t _{LZOE}	\overline{OE} LOW to Low Z ^[6]	0		0		ns
t _{HZOE}	\overline{OE} HIGH to High Z ^[6, 7]		6		7	ns
t _{LZCE}	\overline{CE} LOW to Low Z ^[6]	3		3		ns
t _{HZCE}	\overline{CE} HIGH to High Z ^[6, 7]		6		7	ns
t _{PU}	\overline{CE} LOW to Power-Up	0		0		ns
t _{PD}	\overline{CE} HIGH to Power-Down		12		15	ns
t _{DBE}	Byte Enable to Data Valid		6		7	ns
t _{LZBE}	Byte Enable to Low Z	0		0		ns
t _{HZBE}	Byte Disable to High Z		6		7	ns
Write Cycle^[8]						
t _{WC}	Write Cycle Time	12		15		ns
t _{SCE}	\overline{CE} LOW to Write End	9		10		ns
t _{AW}	Address Set-Up to Write End	8		10		ns
t _{HA}	Address Hold from Write End	0		0		ns
t _{SA}	Address Set-Up to Write Start	0		0		ns
t _{PWE}	\overline{WE} Pulse Width	8		10		ns
t _{SD}	Data Set-Up to Write End	6		8		ns
t _{HD}	Data Hold from Write End	0		0		ns
t _{LZWE}	\overline{WE} HIGH to Low Z ^[6]	3		3		ns
t _{HZWE}	\overline{WE} LOW to High Z ^[6, 7]		6		7	ns
t _{BW}	Byte Enable to End of Write	8		9		ns

Notes:

- Test conditions assume signal transition time of 3 ns or less, timing reference levels of 1.5V, input pulse levels of 0 to 3.0V, and output loading of the specified I_{OL}/I_{OH} and 30-pF load capacitance.
- At any given temperature and voltage condition, t_{HZCE} is less than t_{LZCE}, t_{HZOE} is less than t_{LZOE}, and t_{HZWE} is less than t_{LZWE} for any given device.
- t_{HZOE}, t_{HZBE}, t_{HZCE}, and t_{HZWE} are specified with a load capacitance of 5 pF as in part (b) of AC Test Loads. Transition is measured ±500 mV from steady-state voltage.
- The internal write time of the memory is defined by the overlap of CE LOW, WE LOW and BHE / BLE LOW. CE, WE and BHE / BLE must be LOW to initiate a write, and the transition of these signals can terminate the write. The input data set-up and hold timing should be referenced to the leading edge of the signal that terminates the write.

Switching Waveforms

Read Cycle No. 1^[9, 10]

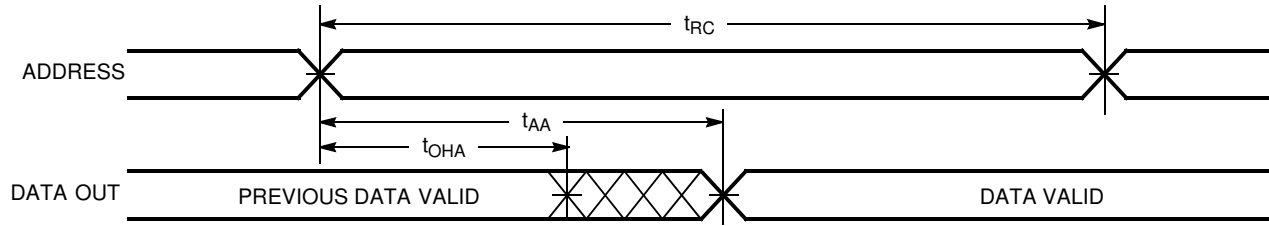

Read Cycle No. 2 (\overline{OE} Controlled)^[10, 11]

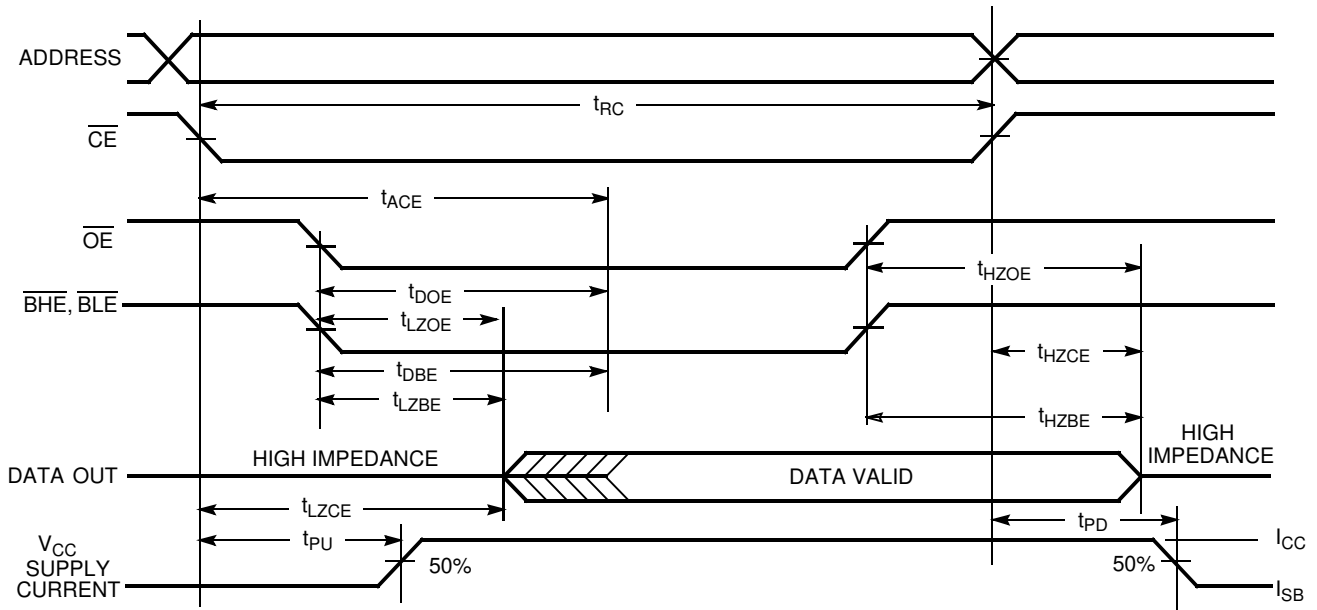

Notes:

- 9. Device is continuously selected. \overline{OE} , \overline{CE} , \overline{BHE} and/or \overline{BLE} = V_{IL} .
- 10. \overline{WE} is HIGH for read cycle.
- 11. Address valid prior to or coincident with \overline{CE} transition LOW.

Switching Waveforms (continued)

Write Cycle No. 1 (\overline{CE} Controlled)^[12, 13]

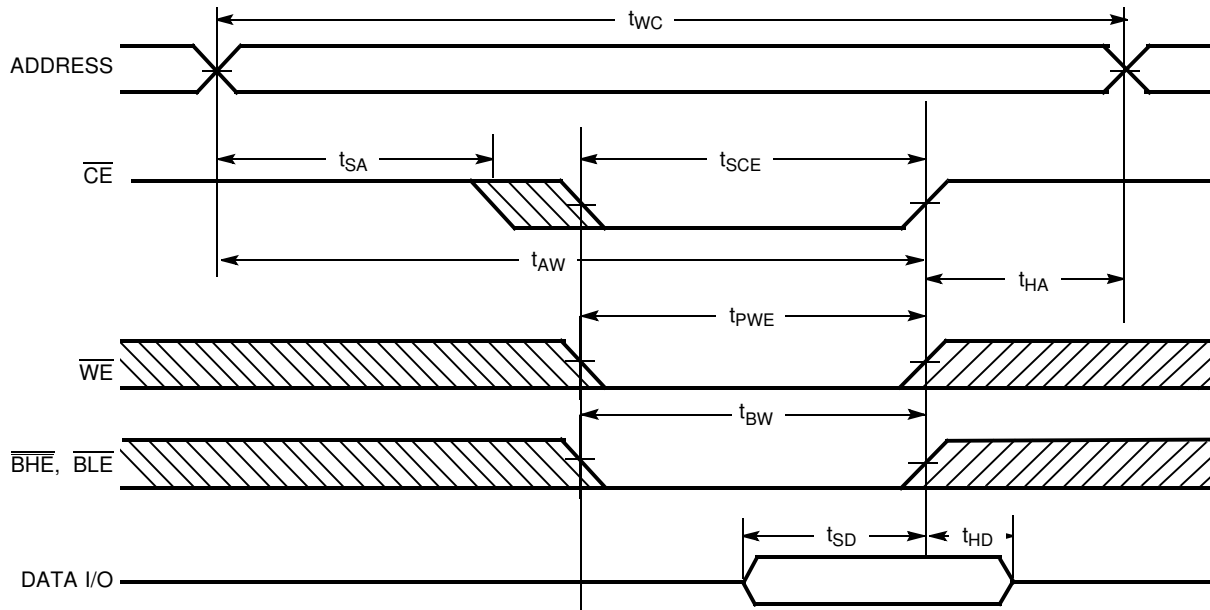

Write Cycle No. 2 (\overline{BLE} or \overline{BHE} Controlled)

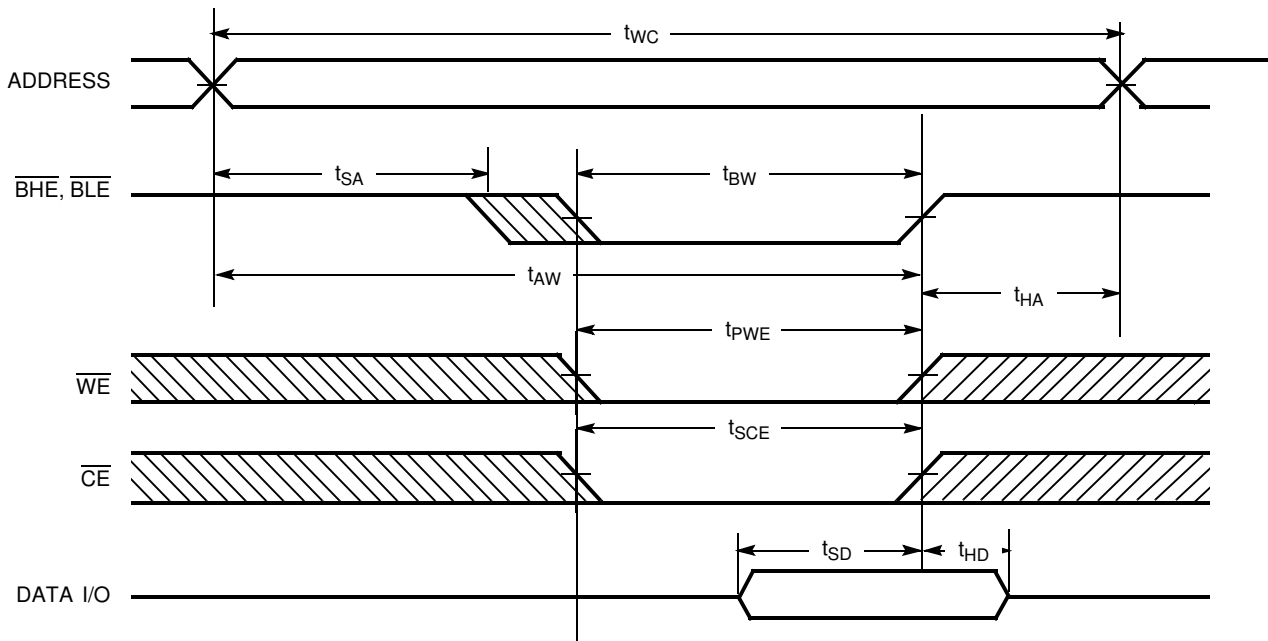

Notes:

- 12. Data I/O is high impedance if \overline{CE} or \overline{BHE} and/or $\overline{BLE} = V_{IH}$.
- 13. If \overline{CE} goes HIGH simultaneously with \overline{WE} going HIGH, the output remains in a high-impedance state.

Switching Waveforms (continued)

Write Cycle No. 3 (\overline{WE} Controlled, \overline{OE} LOW)

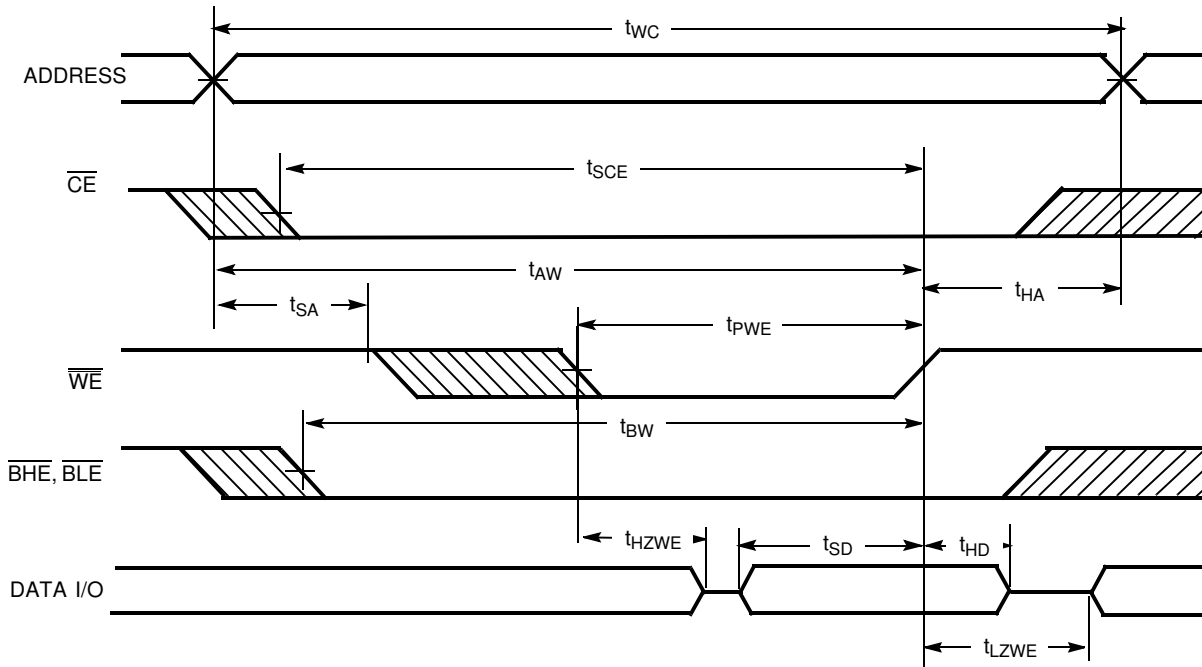

Truth Table

\overline{CE}	\overline{OE}	\overline{WE}	\overline{BLE}	\overline{BHE}	I/O ₁ -I/O ₈	I/O ₉ -I/O ₁₆	Mode	Power
H	X	X	X	X	High Z	High Z	Power-Down	Standby (I _{SB})
L	L	H	L	L	Data Out	Data Out	Read – All bits	Active (I _{CC})
			L	H	Data Out	High Z	Read – Lower bits only	Active (I _{CC})
			H	L	High Z	Data Out	Read – Upper bits only	Active (I _{CC})
L	X	L	L	L	Data In	Data In	Write – All bits	Active (I _{CC})
			L	H	Data In	High Z	Write – Lower bits only	Active (I _{CC})
			H	L	High Z	Data In	Write – Upper bits only	Active (I _{CC})
L	H	H	X	X	High Z	High Z	Selected, Outputs Disabled	Active (I _{CC})
L	X	X	H	H	High Z	High Z	Selected, Outputs Disabled	Active (I _{CC})

Ordering Information

Speed (ns)	Ordering Code	Package Diagram	Package Type	Operating Range
12	CY7C1020B-12VC	51-85082	44-pin (400-Mil) Molded SOJ	Commercial
	CY7C1020B-12VXC		44-pin (400-Mil) Molded SOJ (Pb-free)	
	CY7C1020B-12ZC	51-85087	44-pin TSOP Type II	
	CY7C1020B-12ZXC		44-pin TSOP Type II (Pb-free)	
15	CY7C1020B-15ZC	51-85087	44-pin TSOP Type II	
	CY7C1020B-15ZXC		44-pin TSOP Type II (Pb-free)	

Package Diagrams

44-pin (400-Mil) Molded SOJ (51-85082)

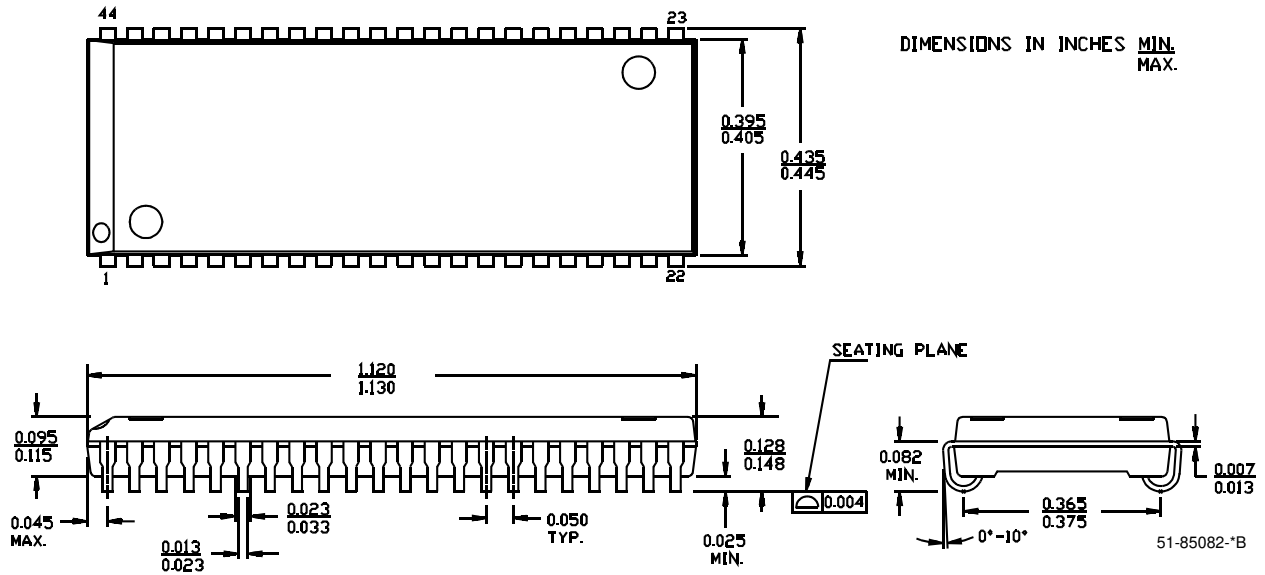

Package Diagrams (continued)

44-pin TSOP II (51-85087)

DIMENSION IN MM (INCH)
MAX
MIN

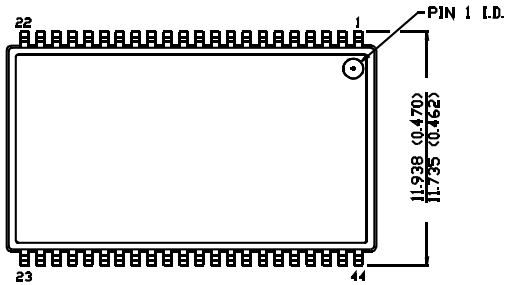

TOP VIEW

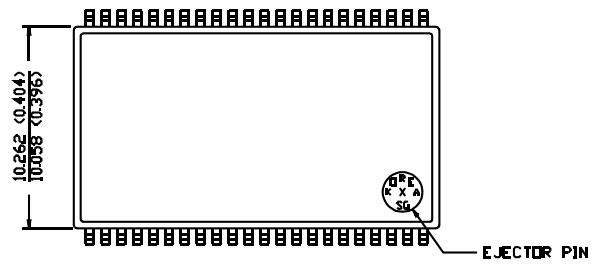

BOTTOM VIEW

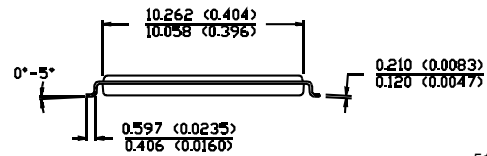
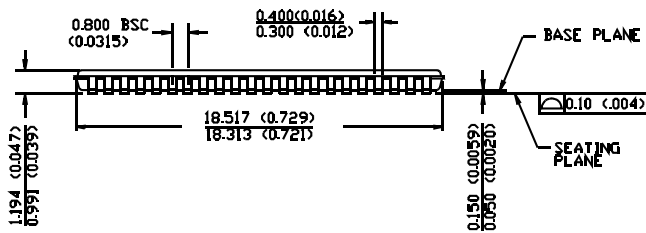

51-85087-A

All product and company names mentioned in this document may be the trademarks of their respective holders.

Document History Page

Document Title: CY7C1020B 32K x 16 Static RAM Document #: 38-05171				
REV.	ECN NO.	Issue Date	Orig. of Change	Description of Change
**	115439	05/09/02	DSG	New Data Sheet
*A	116869	08/21/02	DFP	Added L-Power Specifications.
*B	426747	See ECN	ZSD	Changed the address of Cypress Semiconductor Corporation on Page #1 from "3901 North First Street" to "198 Champion Court". Added thermal resistance table. Updated the ordering information table and replaced the Package Name column with Package Diagram.
*C	465909	See ECN	NXR	Corrected typo in Pin Configuration (Changed A ₁₅ to A ₄) Removed L-Power Specifications Updated the Ordering Information table