



Embedded Storage

**FerriSSD<sup>®</sup> Module**

**SATA Gen 3 DRAM SSD Dx Series**

**Datasheet**

(Simplified Edition)

**Revision 0.4**

**Nov 2018**

## Document Confidentiality Statement

The information contained in these documents is confidential, privileged and only for the information of the intended recipient and should not be disclosed to any other person. It may not be used, published or redistributed in whole, or in part, nor may any of the information contained therein be disclosed without the prior written consent of Silicon Motion, Inc. and its affiliates (collectively "SMI").

The recipient hereby agrees that reading of this datasheet is strictly limited to her/him as authorized by SMI. If any statement, notice, requirement and/or disclaimer set forth hereunder is unacceptable, the recipient shall return this document to SMI's contact window without any delay or it is deemed to be agreed and accepted by the recipient and her/his representing companies, incorporations, or any legal entity of these statements, notices, requirements and/or disclaimers.

## IMPORTANT NOTICE

INFORMATION IN THIS DOCUMENT IS PROVIDED IN CONNECTION WITH PRODUCTS OF SILICON MOTION, INC. AND ITS AFFILIATES (COLLECTIVELY "SMI"). ALL PRODUCT, PRODUCT SPECIFICATIONS AND DATA ARE SUBJECT TO CHANGE WITHOUT NOTICE TO IMPROVE RELIABILITY, FUNCTION OR DESIGN OR OTHERWISE. NO LICENSE, EXPRESS OR IMPLIED, BY ESTOPPEL OR OTHERWISE, TO ANY INTELLECTUAL PROPERTY RIGHTS IS GRANTED BY THIS DOCUMENT. EXCEPT AS PROVIDED IN SMI'S TERMS AND CONDITIONS OF SALE FOR SUCH PRODUCTS, SMI ASSUMES NO LIABILITY WHATSOEVER, AND SMI DISCLAIMS ANY EXPRESS OR IMPLIED WARRANTY, RELATING TO SALE AND/OR USE OF SMI PRODUCTS INCLUDING LIABILITY OR WARRANTIES FOR FITNESS FOR A PARTICULAR PURPOSE, MERCHANTABILITY, OR INFRINGEMENT OF ANY PATENT, COPYRIGHT OR OTHER INTELLECTUAL PROPERTY RIGHT.

SMI, its agents, and employees, and all persons acting on its or their behalf, disclaim any and all liability for any errors, inaccuracies or incompleteness contained in any datasheet or in any other disclosure relating to any product.

Statements regarding the suitability of products for certain types of applications are based on SMI's knowledge of typical requirements that are often placed on SMI's products in generic applications. Such statements are not binding statements about the suitability of products for a particular application. It is customer's responsibility to validate that a particular product with the properties described in the product specification and/or datasheet is suitable for use in a particular application.

SMI products are not intended for use in medical, life saving, life sustaining, critical control or safety systems, or in nuclear facility applications. SMI may make changes to specifications and product descriptions at any time, without notice. SMI may have patents or pending patent applications, trademarks, copyrights, or other intellectual property rights that relate to the presented subject matter. The furnishing of documents and other materials and information does not constitute any license, express or implied, by estoppel or otherwise, to any such patents, trademarks, copyrights, or other intellectual property rights. The information in this document is furnished for informational use only, is subject to change without notice, and should not be construed as a commitment by SMI. SMI assumes no responsibility or liability for any errors or inaccuracies that may appear in this document or any software that may be provided in association with this document. Except as permitted by the permitted use abovementioned, no part of this document may be reproduced, stored in a retrieval system, or transmitted in any form or by any means without the express written consent of SMI. Contact your local SMI sales office or your distributor to obtain the latest specifications and before placing your product order.

Silicon Motion and Silicon Motion logo are registered trademarks of SMI and/or its affiliates. Other brand names mentioned herein are for identification purposes only and may be trademarks and/or registered trademarks of their respective owners.

**Revision History**

Revision	Date	Description
0.1	Jan 26, 2018	Initial release
0.2	Mar 5, 2018	<ul style="list-style-type: none"><li>• Fixed the function definitions of pin S5 and S6 in FerriSSD M297 (3.2.2)</li><li>• Updated the cover page</li></ul>
0.3	May 2, 2018	Minor text update
0.4	Nov 30, 2018	Released the simplified edition

## Table of Contents

<b>1. Overview</b>	<b>5</b>
1.1 Product Description	5
1.2 Key Features	5
1.3 Block Diagram	7
<b>2. Product Specifications</b>	<b>8</b>
2.1 Host Interface	8
2.2 Supply Voltage	8
<b>3. Physical Specifications</b>	<b>9</b>
3.1 FerriSSD M25 (2.5")	9
3.1.1 FerriSSD M25 Mechanical Drawing	9
3.1.2 FerriSSD M25 Pin Assignments	11
3.2 FerriSSD M297 (Slim Lite)	12
3.2.1 FerriSSD M297 Mechanical Drawing	12
3.2.2 FerriSSD M297 Pin Assignments	13
3.3 FerriSSD M300 (mSATA)	14
3.3.1 FerriSSD M300 Mechanical Drawing	14
3.3.2 FerriSSD M300 Pin Assignments	16
3.4 FerriSSD M.2	18
3.4.1 FerriSSD M.2 Mechanical Drawing	18
3.4.2 FerriSSD M.2 Pin Assignments	21
<b>4. Environmental Conditions</b>	<b>24</b>
4.1 Temperature	24
4.2 Humidity	24
4.3 RoHS	24
<b>5. Reliability</b>	<b>25</b>
5.1 Reliability Specifications	25
5.2 Endurance	25
5.3 Preventive Maintenance	25
<b>6. Ordering Information</b>	<b>26</b>
6.1 Product Coding Rule	26

# 1. Overview

## 1.1 Product Description

---

Silicon Motion leverages the industry leading technologies and experiences to introduce the fully integrated FerriSSD® module in small and light form factors for enterprise/industrial applications such as node/blade server, navigation, thin-client, as well as a variety of embedded applications.

The FerriSSD is designed optimally for a wide range of embedded applications that behaves like a SATA hard drive featuring fast access time and enhanced endurance. Without any moving mechanical parts, The FerriSSD provides a shock-protected and quiet-operating environment for mobile storage requirements. The new generation FerriSSD Dx series with 3D NAND Flash leveraging Silicon Motion's advanced technologies, including IntelligentScan, DataRefresh, high bandwidth LDPC code correction with proprietary RAID engine, and end-to-end data path protection to provide unsurpassed data integrity in a non-volatile storage device designed for mission critical application.

With high reliability, industry-leading performance and programmable firmware, the FerriSSD is the ultimate non-volatile storage solution for today's fast-moving consumer electronics as well as industrial level applications. The FerriSSD module is available in various form factors and densities for different storage needs.

## 1.2 Key Features

---

- Host Interface
  - Industrial Standard SATA Revision 3.1 compliant
  - Industrial Standard ATA/ATAPI-8 and ACS-2 command compliant
  - Supports SATA interface rate of 6Gb/s (backward compatible to 1.5Gb/s and 3Gb/s)
  - Native Command Queuing up to 32 commands
  - SATA Device Sleep (DevSleep)
  - Data Set Management command (TRIM)
  - Supports 28-bit and 48-bit LBA (Logical Block Addressing) mode commands
- High Capacity
  - Supports unformatted capacity up to 256GB
- Small Form Factor
  - FerriSSD M25: 2.5" SATA SSD
  - FerriSSD M297: Slim Lite (MO-297)
  - FerriSSD M300: mSATA (MO-300A)
  - FerriSSD M.2: M.2 SSD (type 2242) and (type 2280)
- Robust Data Protection and Data Reliability
  - Advanced system level protection against unstable power supply
  - SRAM and DRAM ECC protection
  - End-to-end data path protection

- Hardware LDPC ECC engine with hard-decision and soft-decision decoding
- RAID engine offers additional level of data protection
- Internal data shaping optimizes the data endurance
- StaticDataRefresh and EarlyRetirement technologies ensure data integrity and prevent read disturbance
- Early weak block retirement feature
- PowerShield and DataPhoenix technologies support power-down data protection and recovery
  
- SSD Status Monitoring
  - Supports Self-Monitoring, Analysis, and Reporting Technology (S.M.A.R.T.) commands
  
- Advanced Global Wear Leveling
  - Fully utilizes all memory blocks across management units/die(s)
  - Maximizes product lifespan with minimal wear leveling and write amplification overhead
  
- Power Supply: 5V/3.3V <sup>1</sup>
  
- Easy-to-Use
  - The Plug & Play device only requires format/fdisk prior to use
  
- Temperature Range
  - Operating Temperature: 0°C ~ 70°C
  - Extended Operating Temperature: -40°C ~ +85°C
  - Non-Operating and Storage Temperature: -55°C ~ +85°C

---

<sup>1</sup> Power supply 5V applies to FerriSSD M25, FerriSSD M297; 3.3V applies to FerriSSD M300 and FerriSSD M.2.

### 1.3 Block Diagram

Figure 1: FerriSSD Block Diagram

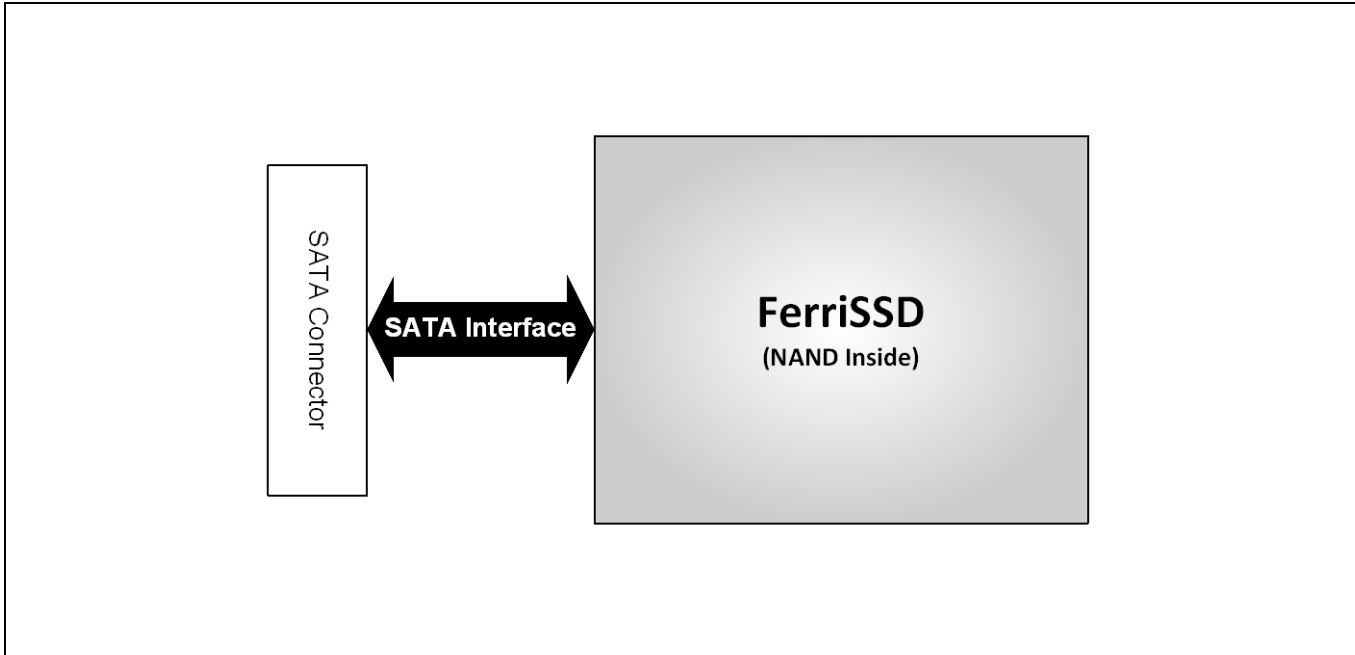

## 2. Product Specifications

### 2.1 Host Interface

The FerriSSD complies to the following industrial standards:

- Serial ATA Revision 3.1
- SATA 1.5Gb/s, 3.0Gb/s, and 6Gb/s interface rate
- ATA/ATAPI-8 and ACS-2 command set

### 2.2 Supply Voltage

**Table 1: FerriSSD Module Supply Voltage**

Model	Min	Typ	Max	Unit
FerriSSD M25	4.5	5	5.5	V
FerriSSD M297	4.5	5	5.5	V
FerriSSD M300	3	3.3	3.6	V
FerriSSD M.2	3.135	3.3	3.465	V



### 3. Physical Specifications

#### 3.1 FerriSSD M25 (2.5")

##### 3.1.1 FerriSSD M25 Mechanical Drawing

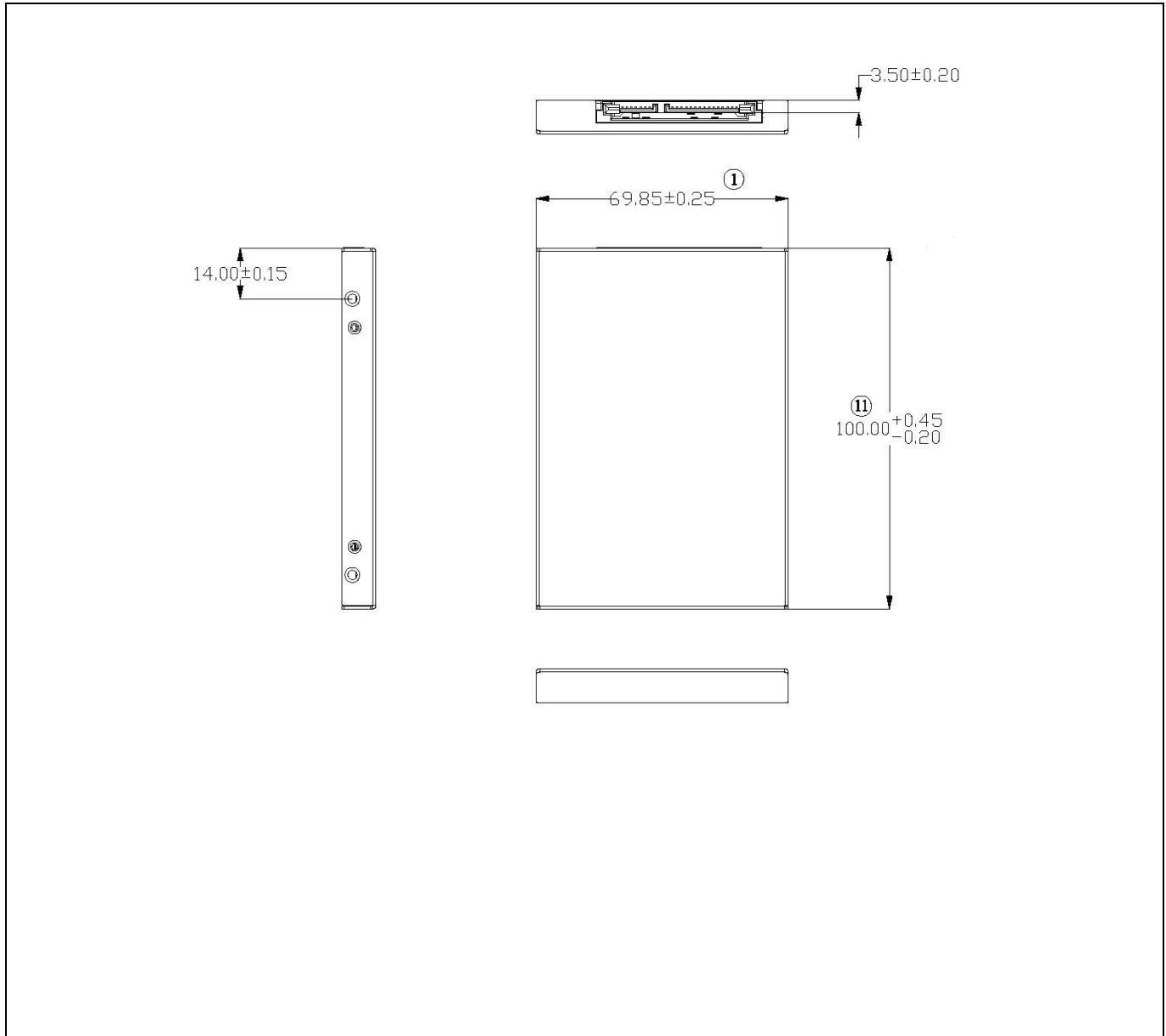

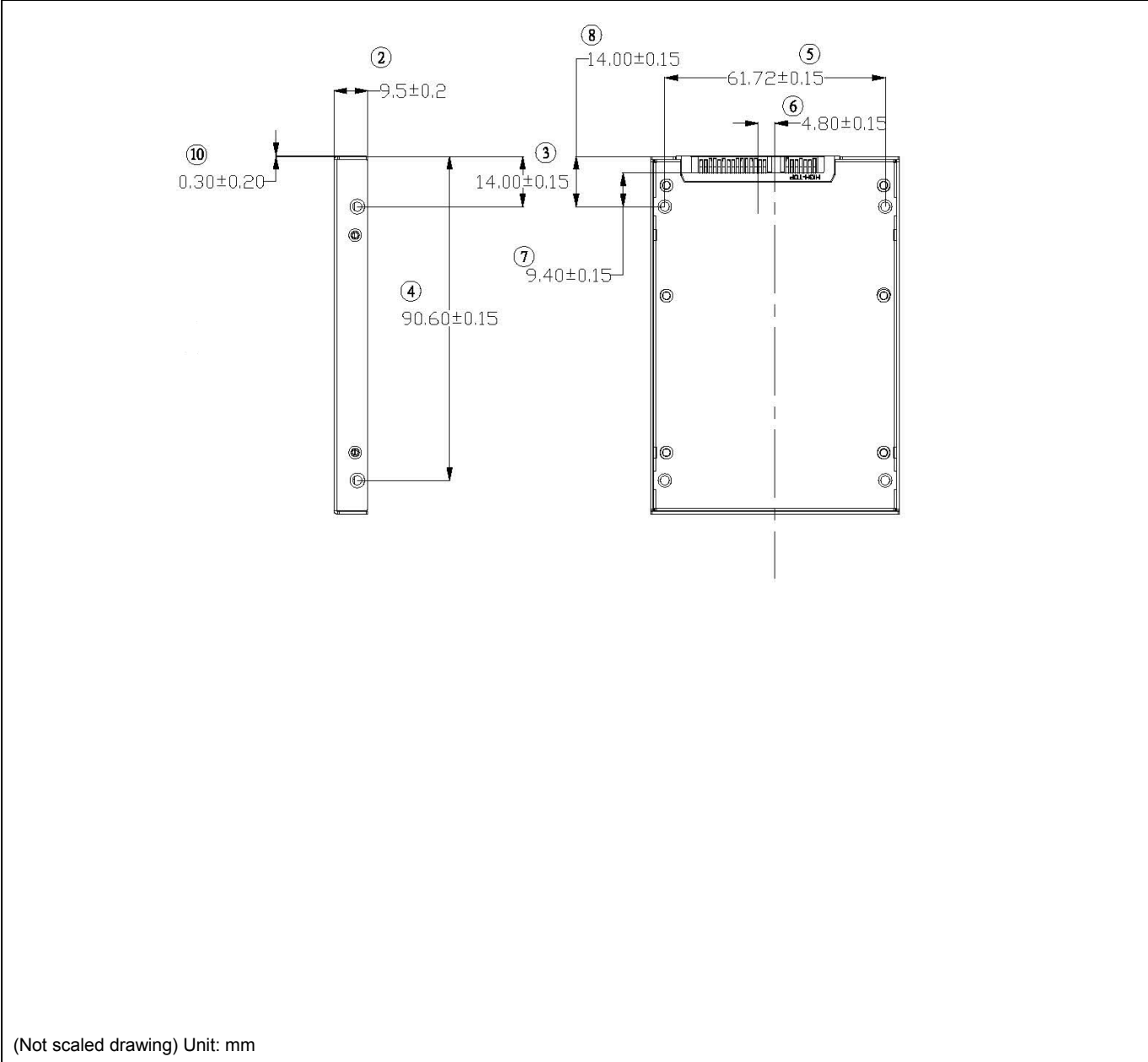

**3.1.2 FerriSSD M25 Pin Assignments**

Segment	Pin	Function	Description
Signal Segment	S1	GND	Ground
	S2	A+	RXp
	S3	A-	RXn
	S4	GND	Ground
	S5	B-	TXn
	S6	B+	TXp
	S7	GND	Ground
Power Segment	P1	Retired <sup>1 2</sup>	
	P2	Retired <sup>1 2</sup>	
	P3	DEVSLP <sup>1</sup>	Enter/Exit Device Sleep
	P4	GND	Ground
	P5	GND	Ground
	P6	GND	Ground
	P7	V <sub>5</sub>	5V Power, Pre-charge
	P8	V <sub>5</sub>	5V Power
	P9	V <sub>5</sub>	5V Power
	P10	GND	Ground
	P11	DAS/DSS/DHU	Device Activity Signal / Disable Staggered Spinup/ Direct Head Unload / Vendor Specific
	P12	GND	Ground
	P13	V <sub>12</sub>	12V Power, Pre-charge
	P14	V <sub>12</sub>	12V Power
	P15	V <sub>12</sub>	12V Power

**Notes:**

- <sup>1</sup> Previous versions of this specification assigned 3.3V to pins P1, P2 and P3. In addition, device plug pins P1, P2 and P3 were required to be bused together.
- <sup>2</sup> It is recommended to have P1 and P2 connected together for the purpose of legacy functionality. Pin P3 should be a no connect if DEVSLP is not implemented.

3.2 FerriSSD M297 (Slim Lite)

3.2.1 FerriSSD M297 Mechanical Drawing

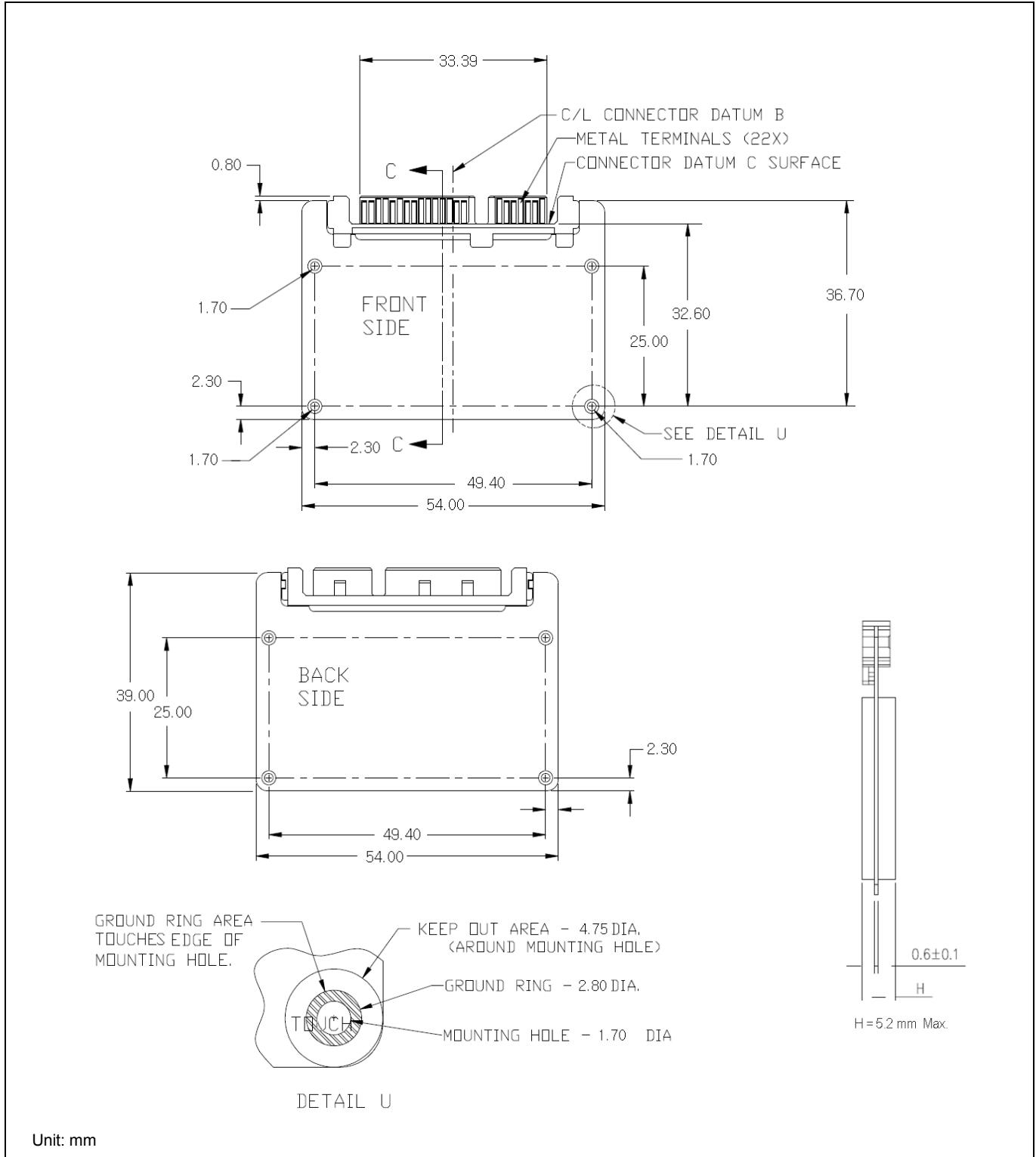

**3.2.2 FerriSSD M297 Pin Assignments**

Segment	Pin	Function	Description
Signal Segment	S1	GND	
	S2	A+	RXp
	S3	A-	RXn
	S4	GND	
	S5	B-	TXn
	S6	B+	TXp
	S7	GND	
Power Segment	P1	Retired	
	P2	Retired	
	P3	DEVSLP	SATA DEVSLP (Device Sleep) Signal
	P4	GND	
	P5	GND	
	P6	GND	
	P7	5V	5V Power
	P8	5V	5V Power
	P9	5V	5V Power
	P10	GND	
	P11	DAS	Device Activity Signal
	P12	GND	
	P13	V12	12V Power
	P14	V12	12V Power
	P15	V12	12V Power

3.3 FerriSSD M300 (mSATA)

3.3.1 FerriSSD M300 Mechanical Drawing

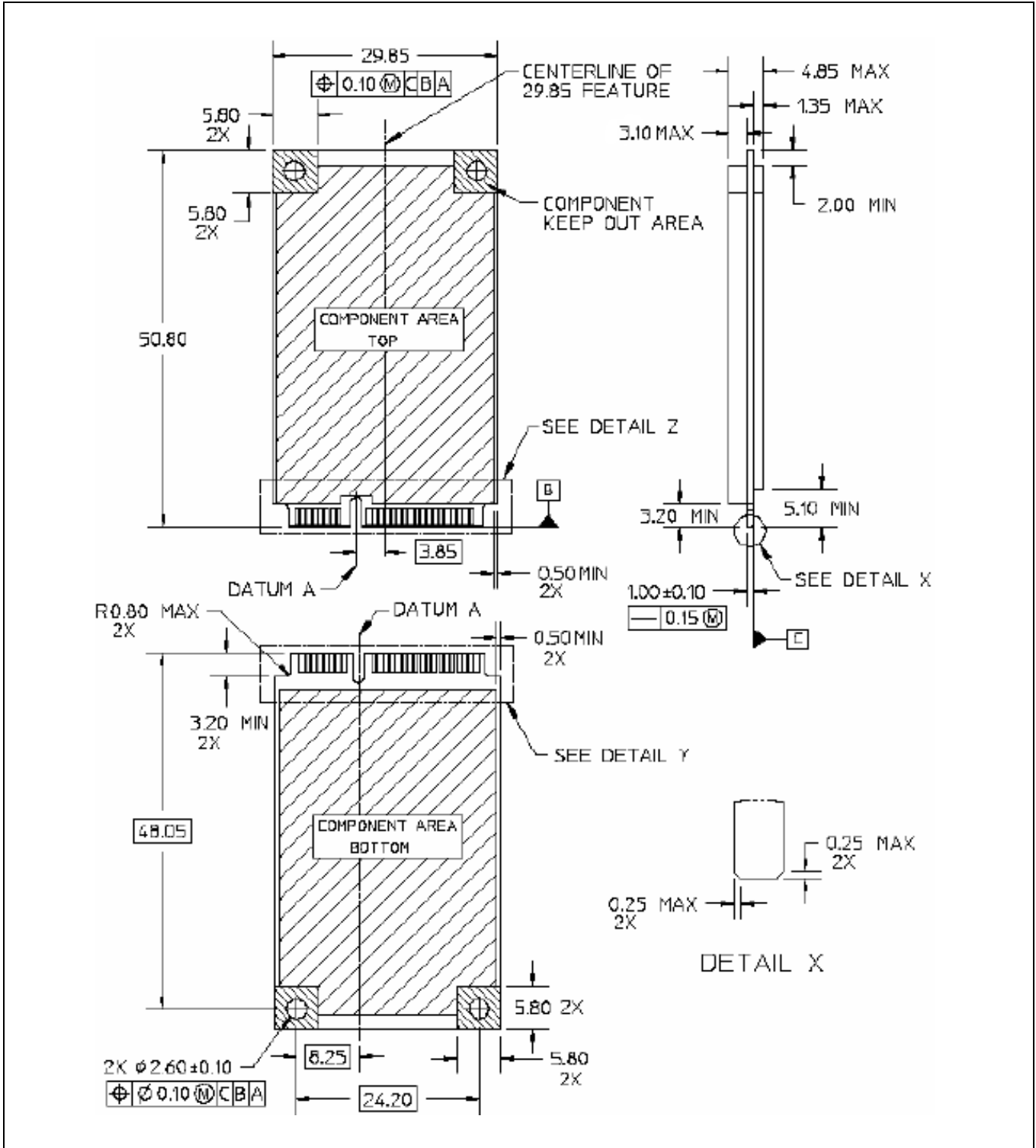

Unit: mm

Detailed Z, Y, W

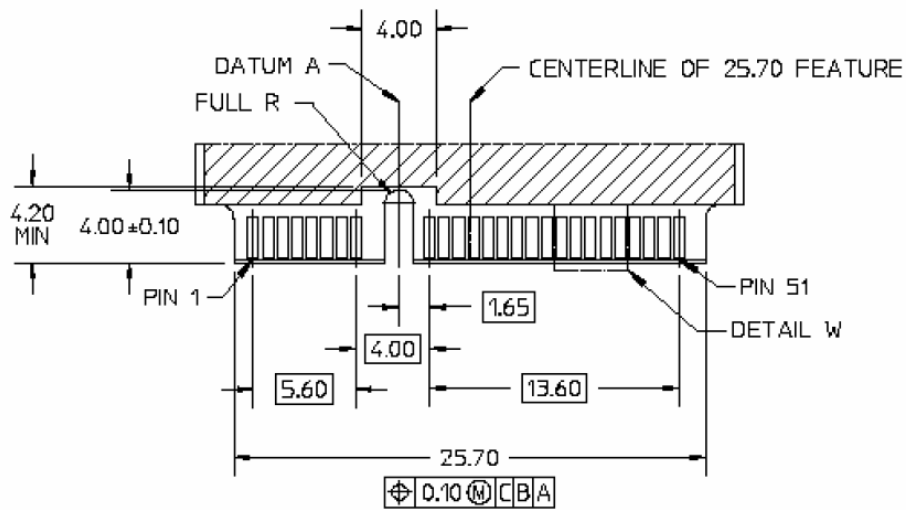

DETAIL Z

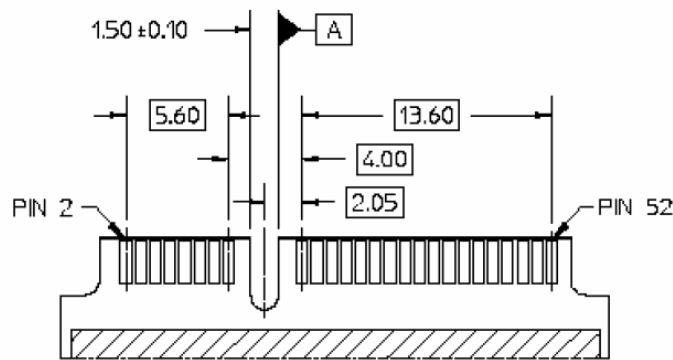

DETAIL Y

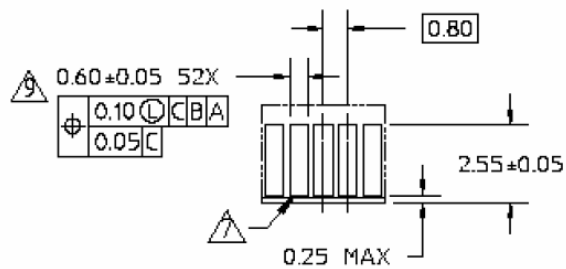

DETAIL W

Unit: mm

**3.3.2 FerriSSD M300 Pin Assignments**

Pin	Type	Description
P1	Reserved	No Connect
P2	+3.3V	3.3V Source
P3	Reserved	No Connect
P4	GND	Return Current Path
P5	Reserved	No Connect
P6	+1.5V	1.5V Source
P7	Reserved	No Connect
P8	Reserved	No Connect
P9	GND	Return Current Path
P10	Reserved	No Connect
P11	Reserved	No Connect
P12	Reserved	No Connect
P13	Reserved	No Connect
P14	Reserved	No Connect
P15	GND	Return Current Path
P16	Reserved	No Connect
P17	Reserved	No Connect
P18	GND	Return Current Path
P19	Reserved	No Connect
P20	Reserved	No Connect
P21	GND	Return Current Path
P22	Reserved	No Connect
P23	+B	Host Receiver Differential Signal Pair
P24	+3.3V	3.3V Source
P25	-B	Host Receiver Differential Signal Pair
P26	GND	Return Current Path
P27	GND	Return Current Path
P28	+1.5V	1.5V Source
P29	GND	Return Current Path
P30	Two Wire Interface	Two Wire Interface Clock Pin 30 is intended for use as a two wire interface to read a memory device to determine device information (an example of this would be for use as SMB bus pins). This pin is not designed to be active in conjunction with the SATA signal differential pairs.
P31	-A	Host Transmitter Differential Signal Pair



Pin	Type	Description
P32	Two Wire Interface	Two Wire Interface Data Pin 32 is intended for use as a two wire interface to read a memory device to determine device information (an example of this would be for use as SMB bus pins). This pin is not designed to be active in conjunction with the SATA signal differential pairs.
P33	+A	Host Transmitter Differential Signal Pair
P34	GND	Return Current Path
P35	GND	Return Current Path
P36	Reserved	No Connect
P37	GND	Return Current Path
P38	Reserved	No Connect
P39	+3.3V	3.3V Source
P40	GND	Return Current Path
P41	+3.3V	3.3V Source
P42	Reserved	No Connect
P43	Device Type	Shall be a No Connect on mSATA Devices
P44	DEVSLP	Enter/Exit DevSleep
P45	Vendor	Vendor Specific / Manufacturing Pin (No connect on the host side)
P46	Reserved	No Connect
P47	Vendor	Vendor Specific / Manufacturing Pin (No connect on the host side)
P48	+1.5V	1.5V Source
P49	DA/DSS	Device Activity Signal / Disable Staggered Spin-up
P50	GND	Return Current Path
P51	Presence Detection	Shall be pulled to GND by device (Presence detection pin provided for tamper proof functionality)
P52	+3.3V	3.3V Source

3.4 FerriSSD M.2

3.4.1 FerriSSD M.2 Mechanical Drawing

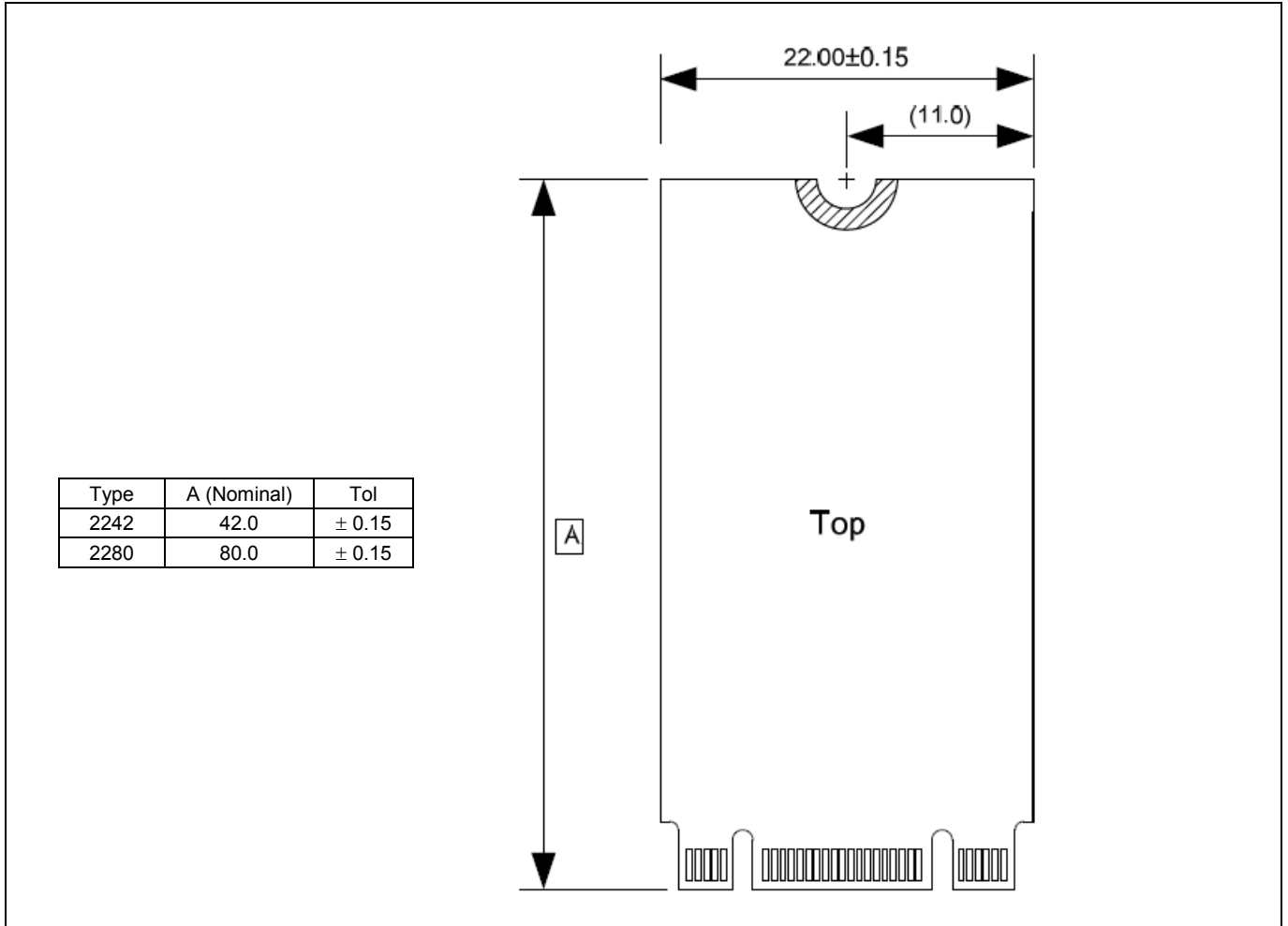

Unit: mm

Type	A (max)	B (max)	C	
			Nominal	Tol
2242	3.1	1.35	0.8	± 0.08
2280	3.1	1.35	0.8	± 0.08

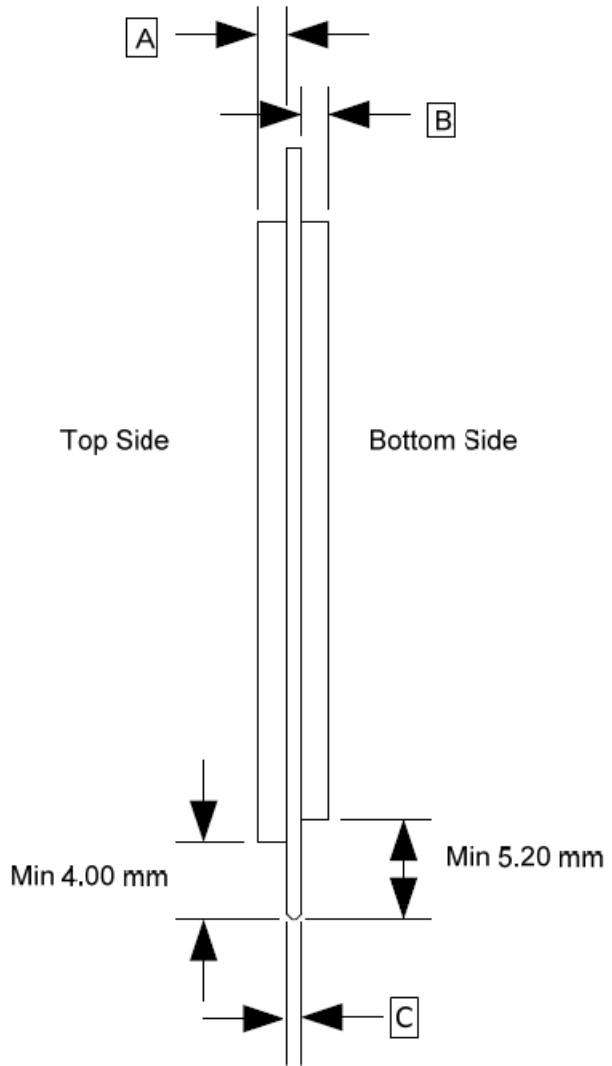

Unit: mm

M.2 Keys (B and M)

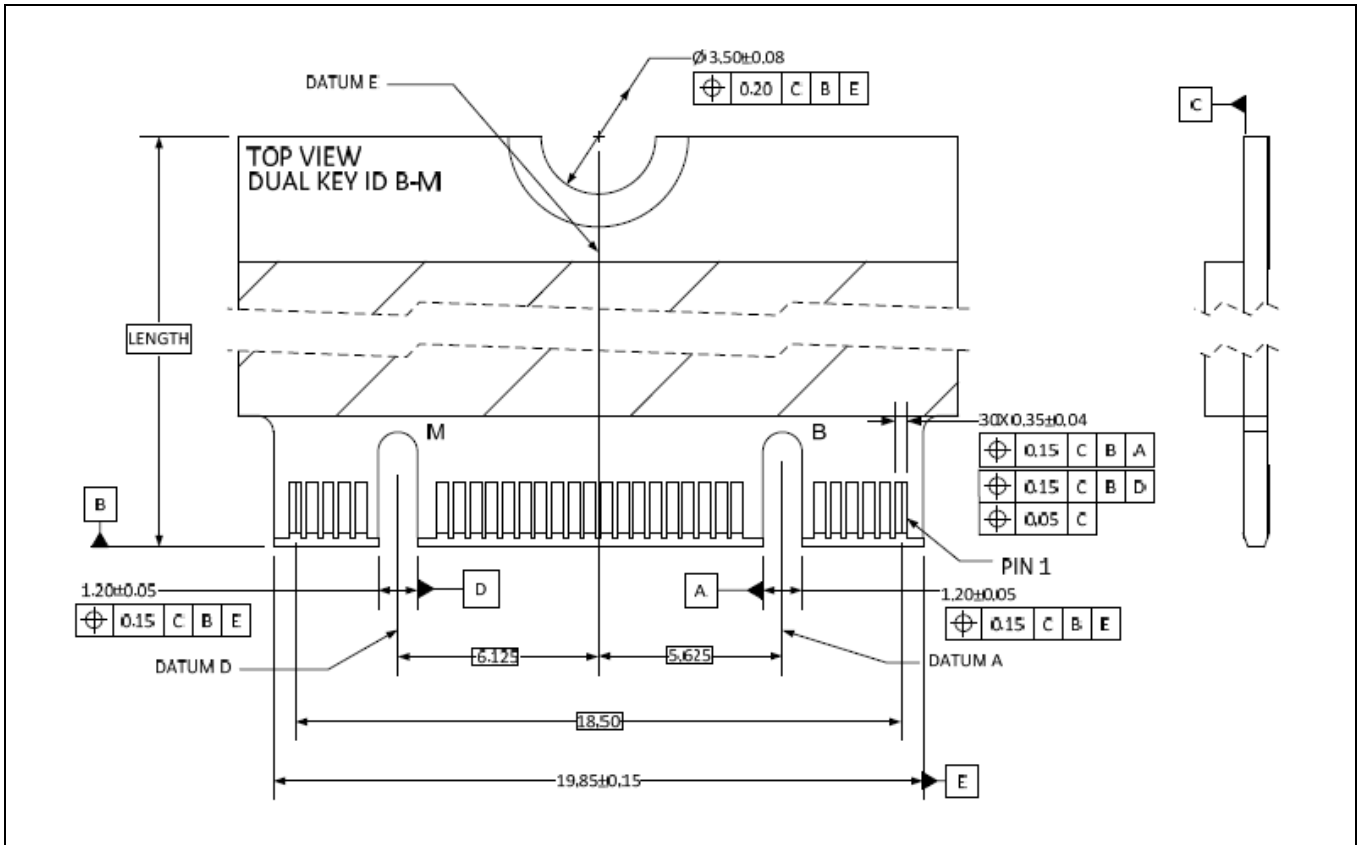

Unit: mm

**3.4.2 FerriSSD M.2 Pin Assignments**

Pin	Type	Description
1	CONFIG_3	Shall be a No connect on SATA M.2 devices
2	3.3V	Supply pin, 3.3V
3	GND	Ground
4	3.3V	Supply pin, 3.3V
5	No connect	No connect
6	Not Available	No connect (used for other purposes)
7	Not Available	No connect (used for other purposes)
8	Not Available	No connect (used for other purposes)
9	No connect	No connect
10	DAS/DSS	Device Activity Signal / Disable Staggered Spinup
11	No connect	No connect (used for other purposes)
12	(removed for key)	Mechanical notch B
13	(removed for key)	Mechanical notch B
14	(removed for key)	Mechanical notch B
15	(removed for key)	Mechanical notch B
16	(removed for key)	Mechanical notch B
17	(removed for key)	Mechanical notch B
18	(removed for key)	Mechanical notch B
19	(removed for key)	Mechanical notch B
20	Not Available	No connect (used for other purposes)
21	CONFIG_0	Shall be a No connect on SATA M.2 devices
22	Not available	No connect (used for other purposes)
23	Not available	No connect (used for other purposes)
24	Not available	No connect (used for other purposes)
25	Not available	No connect (used for other purposes)
26	Not available	No connect (used for other purposes)
27	GND	Ground
28	Not available	No connect (used for other purposes)
29	Not available	No connect (used for other purposes)
30	Not available	No connect (used for other purposes)
31	Not available	No connect (used for other purposes)
32	Not available	No connect (used for other purposes)
33	GND	Ground
34	Not available	No connect (used for other purposes)
35	Not available	No connect (used for other purposes)

Pin	Type	Description
36	Not available	No connect (used for other purposes)
37	Not available	No connect (used for other purposes)
38	DEVSLP	Device Sleep, input. If driven high the host is informing the SSD to enter a low power state.
39	GND	Ground
40	Not available	No connect (used for other purposes)
41	SATA-B+	Host receiver differential signal pair
42	Not available	No connect (used for other purposes)
43	SATA-B-	Host receiver differential signal pair
44	Not available	No connect (used for other purposes)
45	GND	Ground
46	Not available	No connect (used for other purposes)
47	SATA-A-	Host transmitter differential signal pair
48	Not available	No connect (used for other purposes)
49	SATA-A+	Host transmitter differential signal pair
50	Not available	No connect (used for other purposes)
51	GND	Ground
52	Not available	No connect (used for other purposes)
53	Not available	No connect (used for other purposes)
54	Not available	No connect (used for other purposes)
55	Not available	No connect (used for other purposes)
56	MFG1	Manufacturing pin. Use determined by vendor <sup>1</sup>
57	GND	Ground
58	MFG2	Manufacturing pin. Use determined by vendor <sup>1</sup>
59	(removed for key)	Mechanical notch M
60	(removed for key)	Mechanical notch M
61	(removed for key)	Mechanical notch M
62	(removed for key)	Mechanical notch M
63	(removed for key)	Mechanical notch M
64	(removed for key)	Mechanical notch M
65	(removed for key)	Mechanical notch M
66	(removed for key)	Mechanical notch M
67	Not available	No connect (used for other purposes)
68	Not available	No connect (used for other purposes)
69	CONFIG_1	Shall be a No connect on SATA M.2 devices
70	3.3V	Supply pin, 3.3V

**Note**<sup>1</sup>: No connect on a host.

Pin	Type	Description
71	GND	Ground
72	3.3V	Supply pin, 3.3V
73	GND	Ground
74	3.3V	Supply pin, 3.3V
75	CONFIG_2	Shall be a No connect on SATA M.2 devices

## 4. Environmental Conditions

### 4.1 Temperature

**Table 2: Temperature Related Specifications**

Parameter	Specifications
C-temp Operating Temperature	0°C ~ 70°C
I-temp Operating Temperature	-40°C ~ +85°C
Non-Operating Temperature	-55°C ~ +85°C
Storage Temperature	-55°C ~ +85°C

### 4.2 Humidity

**Table 3: Humidity Related Specifications**

Parameter	Specifications
<b>Operating Humidity</b>	
Humidity	5% to 95% (Non condensation)
<b>Non-Operating Humidity</b>	
Humidity (Non condensation)	5% to 95%
Maximum Relative Humidity Gradient	20% per hour

### 4.3 RoHS

Compliant to RoHS (Restriction of Hazardous Substances Directive) 2.0.



## 5. Reliability

### 5.1 Reliability Specifications

**Table 4: Reliability Specifications**

Type	UBER	MTBF
CommercialFerri	1 sector in $10^{16}$ bits read, max	1,200,000 hours

**Notes:**

1. UBER: Uncorrectable bit error rate will not exceed one sector in the specified number of bits read. Refer to the JEDEC SSD specifications for detailed definition.
2. Mean Time Between Failure is estimated based on FIT value. FIT (Failure in Time) test is conducted at SMI internal test lab with SMI RDT (Reliability Demonstration Test).

### 5.2 Endurance

Please contact SMI representative for the endurance information.

### 5.3 Preventive Maintenance

No preventive maintenance is required.

## 6. Ordering Information

### 6.1 Product Coding Rule

**Table 5: Product Code Definitions**

Example: M B 6 1 9 G X 8 □ DE □	
M	Ferri Module
B	Form Factor <ul style="list-style-type: none"> <li>• A = FerriSSD M25 (2.5" case)</li> <li>• B = FerriSSD M297 (Slim Lite)</li> <li>• C = FerriSSD M300 (mSATA)</li> <li>• D = FerriSSD M.2 (22 x 42 mm)</li> <li>• E = FerriSSD M.2 (22 x 80 mm)</li> </ul>
6	Ferri Family
1	Type / Interface <ul style="list-style-type: none"> <li>• 1 = CommercialFerri / SATA</li> </ul>
9	9 = Embedded DRAM
G	Package: MCM TFBGA
X	Operating Temperature <ul style="list-style-type: none"> <li>• X = 0°C ~ 70°C (C-temp)</li> <li>• E = -40°C ~ +85°C (I-temp)</li> </ul>
C	Density <ul style="list-style-type: none"> <li>• 4 = 8GB</li> <li>• 8 = 8GB</li> <li>• A = 16GB</li> <li>• B = 32GB</li> <li>• C = 64GB</li> <li>• D = 128GB</li> <li>• E = 256GB</li> </ul>
□	PCB Revision
DE	Product Revision
□	BOM Version

Note: See FerriSSD Product Selection Guide for specific ordering numbers.