

MATERIAL:
 1.HOUSING: LCP, GLASS FIBER FILLED, BK
 2.CONTACT: COPPER ALLOY (T=0.15mm)
 3.MID PLATE: STAINLESS STEEL
 4.SHELL: STAINLESS STEEL .

FINISH:
 CONTACT: SEE ORDER INFORMATION
 SHELL: NICKEL PLATING

Ordering Code:

CU32 16 S * S B L R 004 -NH
 ① ② ③ ④ ⑤ ⑥ ⑦ ⑧ ⑨

- ① Series No:CU32
- ② No of Circuits:16Pin
- ③ Contact type:S= Socket
- ④ Contact Plating option:

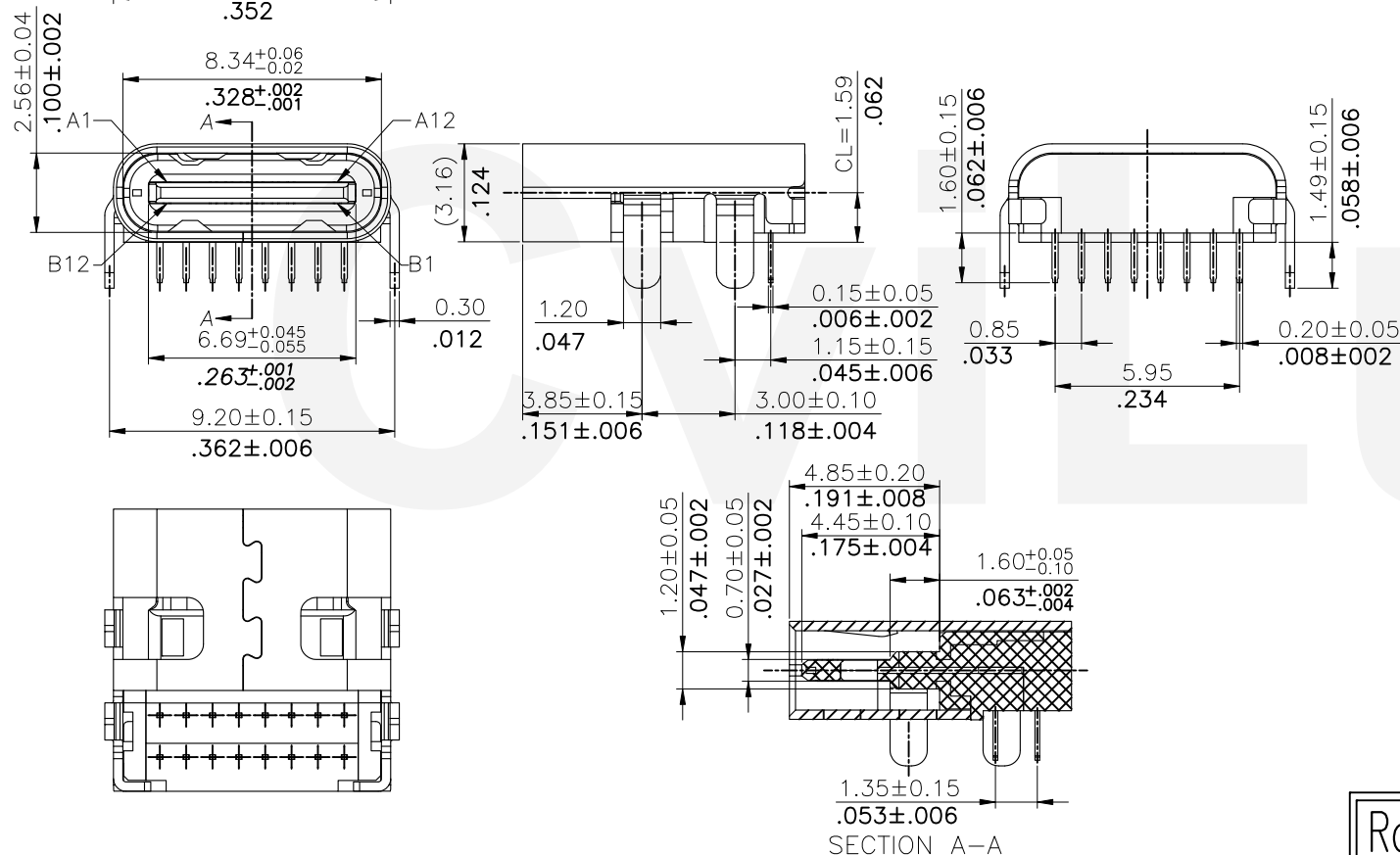

A= Gold Flash plated on Contact area,
 Matte Tin plated on Solderails,
 Nickel underplating over all

B= 15u" gold plated on Contact area,
 Matte Tin plated on Solderails,
 Nickel underplating over all

C= 30u" gold plated on Contact area,
 Matte Tin plated on Solderails,
 Nickel underplating over all

2= Gold flash over 50u" (1.27um) Nickel

- ⑤ Shell Material & Plating:
S=STAINLESS STEEL
- ⑥ Contact Material: B=COPPER ALLOY
- ⑦ Insulator Material & Color option:
L= LCP Black
- ⑧ Packing Option: R= Tape & Reel
- ⑨ -NH: For Lead Free wave or IR Reflow Processes & Halogen Free

RoHS Compliant

Lead Free Process

Halogen-Free

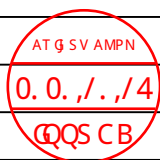

4					DATE	UNIT: mm / inch	TITLE:	瀚荃股份有限公司 Cvilux Corporation			
3				DRAWN BY: Kevin	09/02-20'	TOLERANCE UNLESS OTHERWISE SPECIFIED	Type C/F 16 PIN CL=1.59mm DIP TYPE TOP MOUNT TYPE				
2				ENGINEER: Kevin	09/02-20'	.X ± 0.25/.010 X.* ± 4'	MATERIAL:				
1				CHECKED BY: Keny	09/02-20'	.XX ± 0.20/.008 .X.* ± 2'	FINISH:				
SYM	NAME	DATE	REVISIONS	APPROVED BY: Keny	09/02-20'	.XXX ± 0.10/.004 .XX.* ±					
								DRAWING NO.	CU32S04SA	PART NO.	CU3216S*SBLR004-NH
								SCALE	1 / 1	SHEET	1 OF 3

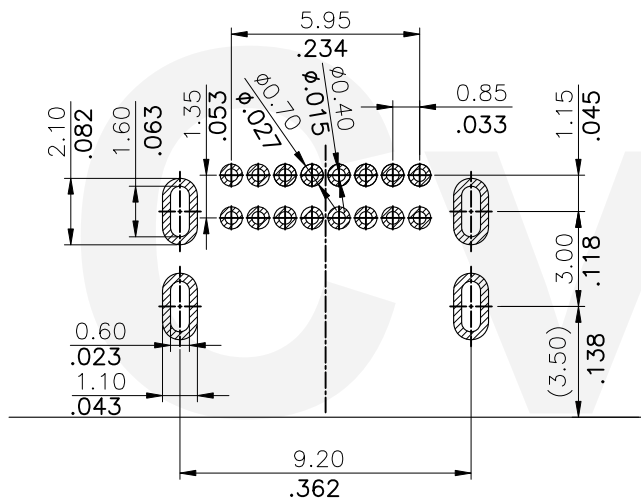
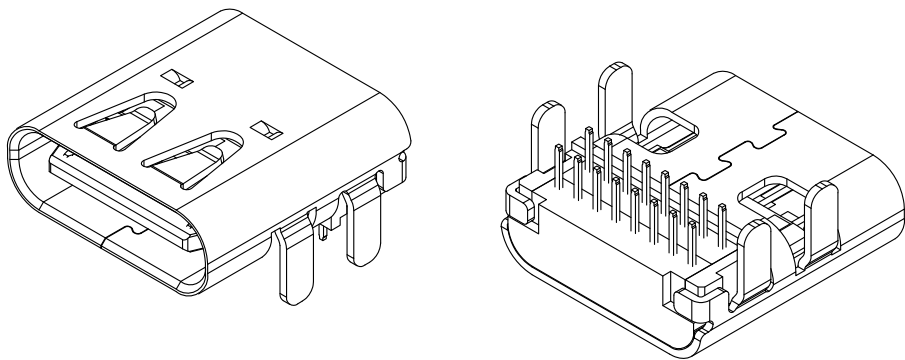

RECOMMENDED P.C.B. LAYOUT (T:1.00mm)

TOLERANCE UNSPECIFIED $\pm 0.05\text{mm}$

USB TYPE-C FULL-FEATURED RECEPTACLE INTERFACE PIN ASSIGNMENTS

PIN	Signal Name	Description	PIN	Signal Name	Description
A1	GND	Ground return	B12	GND	Ground return
A2	X		B11	X	
A3			B10		
A4	Vbus	Bus Power	B9	VBUS	Bus Power
A5	CC1	Configuration Channel	B8	SBU2	Sideband Use(SBU)
A6	Dp1	Positive half of the USB 2.0 differential pair-Position 1	B7	Dn2	Positive half of the USB 2.0 differential pair-Position 2
A7	Dn1	Negative half of the USB 2.0 differential pair-Position 1	B6	Dp2	Negative half of the USB 2.0 differential pair-Position 2
A8	SBU1	Sideband Use(SBU)	B5	CC2	Configuration Channel
A9	VBUS	Bus Power	B4	VBUS	Bus Power
A10	X		B3	X	
A11			B2		
A12	GND	Ground return	B1	GND	Ground return

RoHS Compliant

Lead Free Process

Halogen-Free

4					DATE	UNIT: mm / inch	TITLE:	 瀚荃股份有限公司 CviLux Corporation	
3				DRAWN BY: Kevin	09/02-20'	TOLERANCE UNLESS OTHERWISE SPECIFIED	Type C/F 16 PIN CL=1.59mm DIP TYPE TOP MOUNT TYPE		
2				ENGINEER: Kevin	09/02-20'	.X $\pm 0.25/010$ X.* $\pm 4'$	MATERIAL:		
1				CHECKED BY: Keny	09/02-20'	.XX $\pm 0.20/008$.X* $\pm 2'$	FINISH:		
SYM	NAME	DATE	REVISIONS	APPROVED BY: Keny	09/02-20'	.XXX $\pm 0.10/004$.XX* \pm	DRAWING NO. CU32S04SA	PART NO. CU3216S*SBLR004-NH	
								SCALE 1 / 1	SHEET 2 OF 3

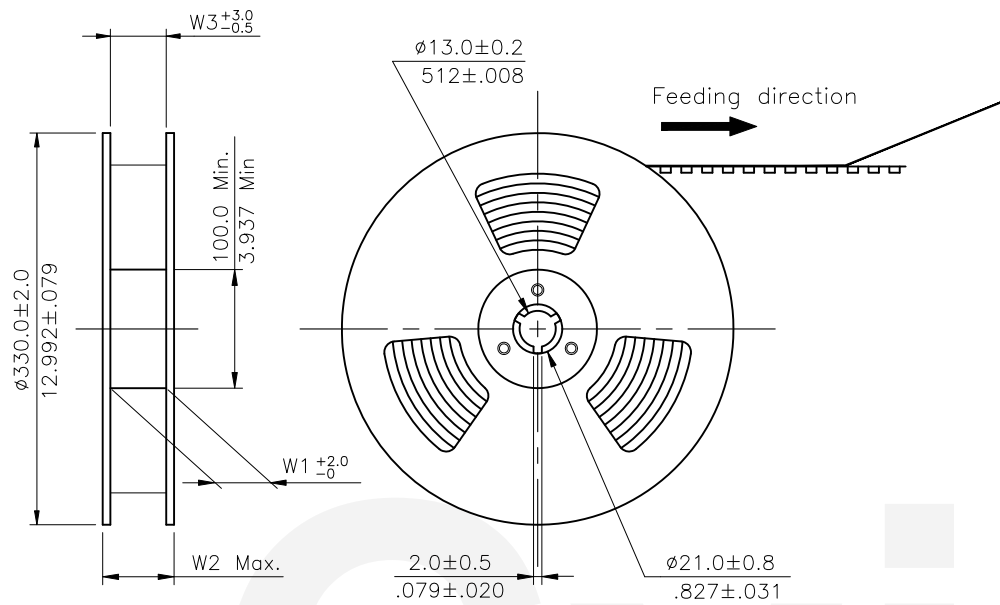

NOTE :

- * Reel Material : HIPS
- * Carrier Material : Black, Conductive Polystyrene Alloy
- * Cover Tape Material : Polyester
- * Cover Tape Peel Strength : 0.1N – 1.3N
- * Carrier camber is within 1mm in 250mm
- * All dimensions meet EIA-481-B requirements.
- * Quantity : 800 PCS/Reel

Dimension				Packing (Reel/Carton)
E	W1	W2	W3	
24.0(.945)	24.5(.965)	30.5(1.201)	24.5(.965)	10

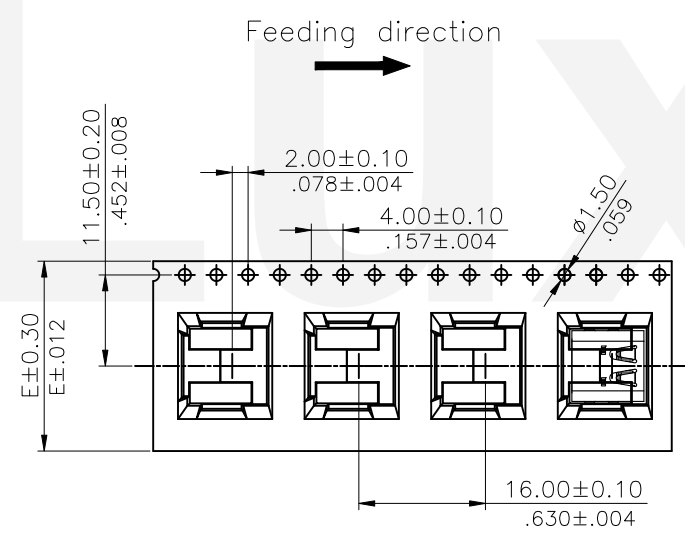
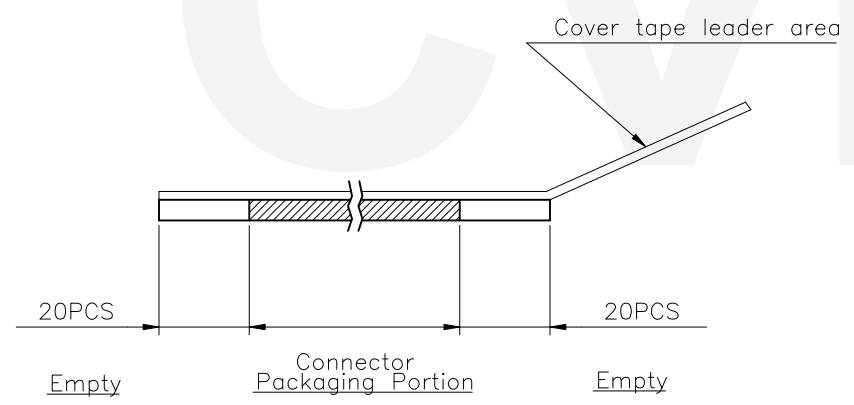

RoHS Compliant

Lead Free Process

Halogen-Free

4				DATE	UNIT: mm / inch	TITLE:
3				DRAWN BY: Kevin	TOLERANCE UNLESS OTHERWISE SPECIFIED	Type C/F 16 PIN CL=1.59mm DIP TYPE TOP MOUNT TYPE
2				ENGINEER: Kevin		.X ± 0.25/.010
1				CHECKED BY: Keny	.XX ± 0.20/.008	FINISH:
SYM	NAME	DATE	REVISIONS	APPROVED BY: Keny	.XXX ± 0.10/.004	



瀚荃股份有限公司
CvILux Corporation

DRAWING NO.	CU32S04SA	PART NO.	CU3216S*SBLR004-NH
SCALE	1 / 1	SHEET	3 OF 3