

LOC	DIST	REVISIONS					
GP	00	P	LTN	DESCRIPTION	DATE	DWN	APVD
		B3		ADDED NEW DASH NUMBER -8	12NOV2009	HL	SY
		B5		REV PER ECR-10-001570	26FEB2010	HL	SY

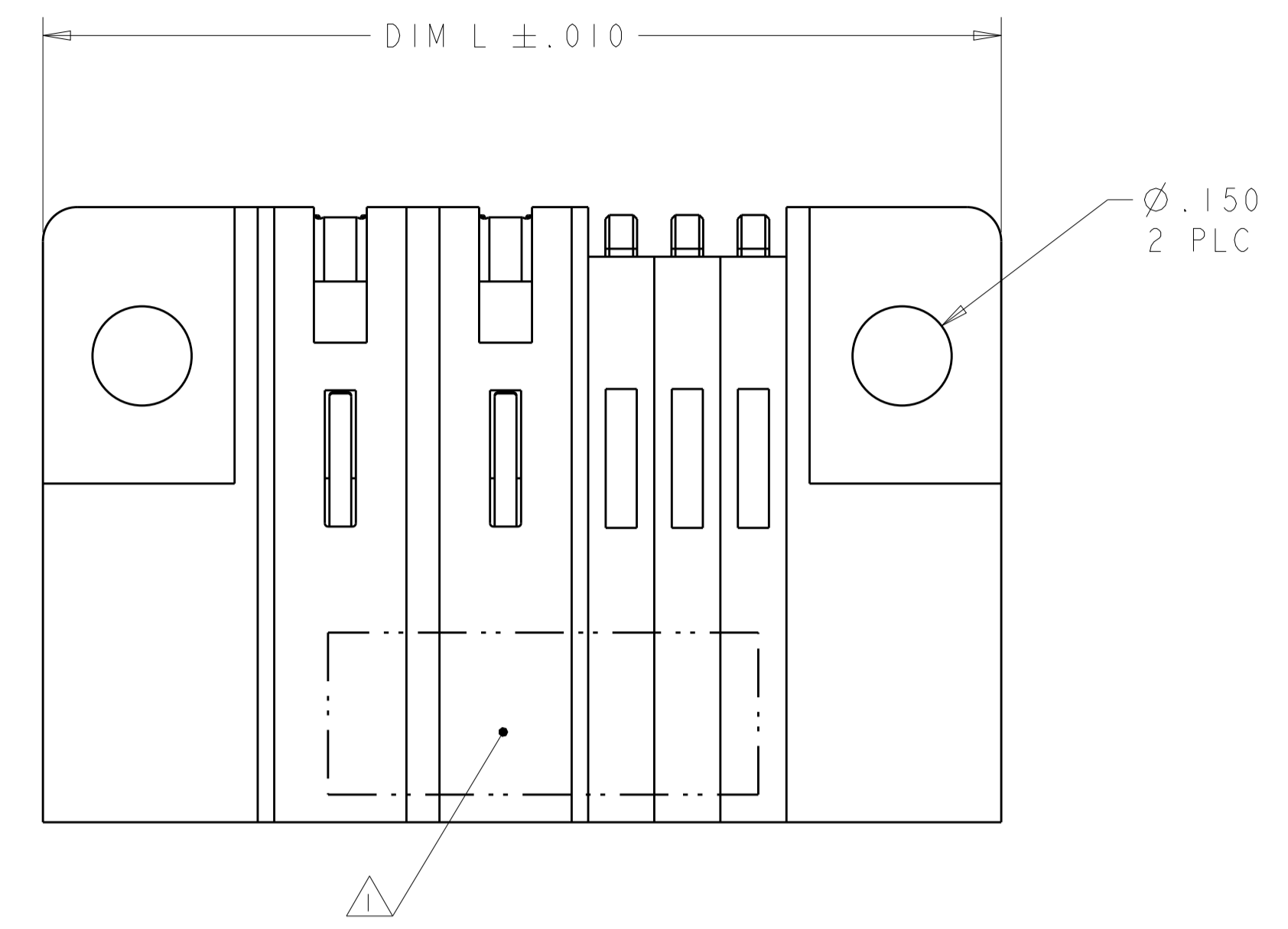

- 1 "AMP", PART NUMBER, AND DATECODE TO BE MARKED IN AREA SHOWN. PARTS UNDER 2.00 LONG MAY BE MARKED ON BOTH SIDES.
- 2 MATERIAL: HOUSING - GLASS FILLED HIGH TEMP THERMO PLASTIC, UL94 V-0
SIGNAL CONTACT - COPPER ALLOY
POWER CONTACT - HIGH CONDUCTIVITY COPPER ALLOY
- 3 CONTACT PLATING: NOBLE METAL PLATING ON CONTACT FUNCTIONAL AREA OF POWER AND SIGNAL CONTACTS
- 4 MECHANICAL CONNECTOR KEEP OUT ZONE.
- 5 DATUM AND BASIC DIMENSIONS ESTABLISHED BY CUSTOMER.
- 6 PCB - HOLE DIAMETERS ARE FINISHED HOLE SIZE.
- 7 PCB - .0453±.0010 DRILLED HOLES PLATED WITH .0003 MIN Sn OVER .001 TO .003 Cu PLATING TO ACHIEVE A .040 DIA HOLE.

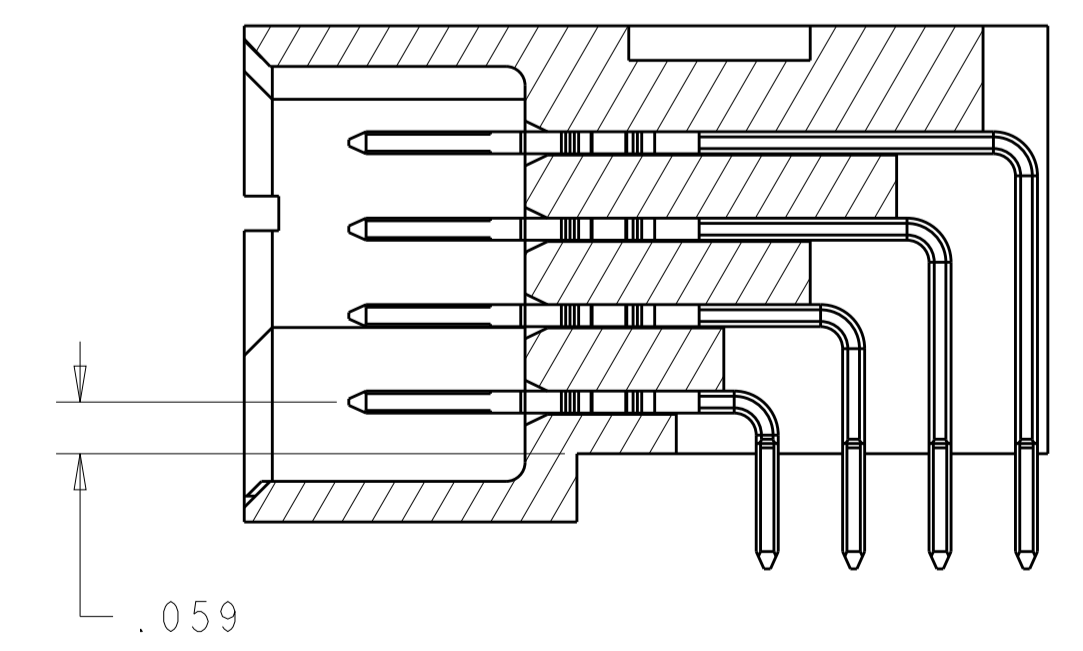
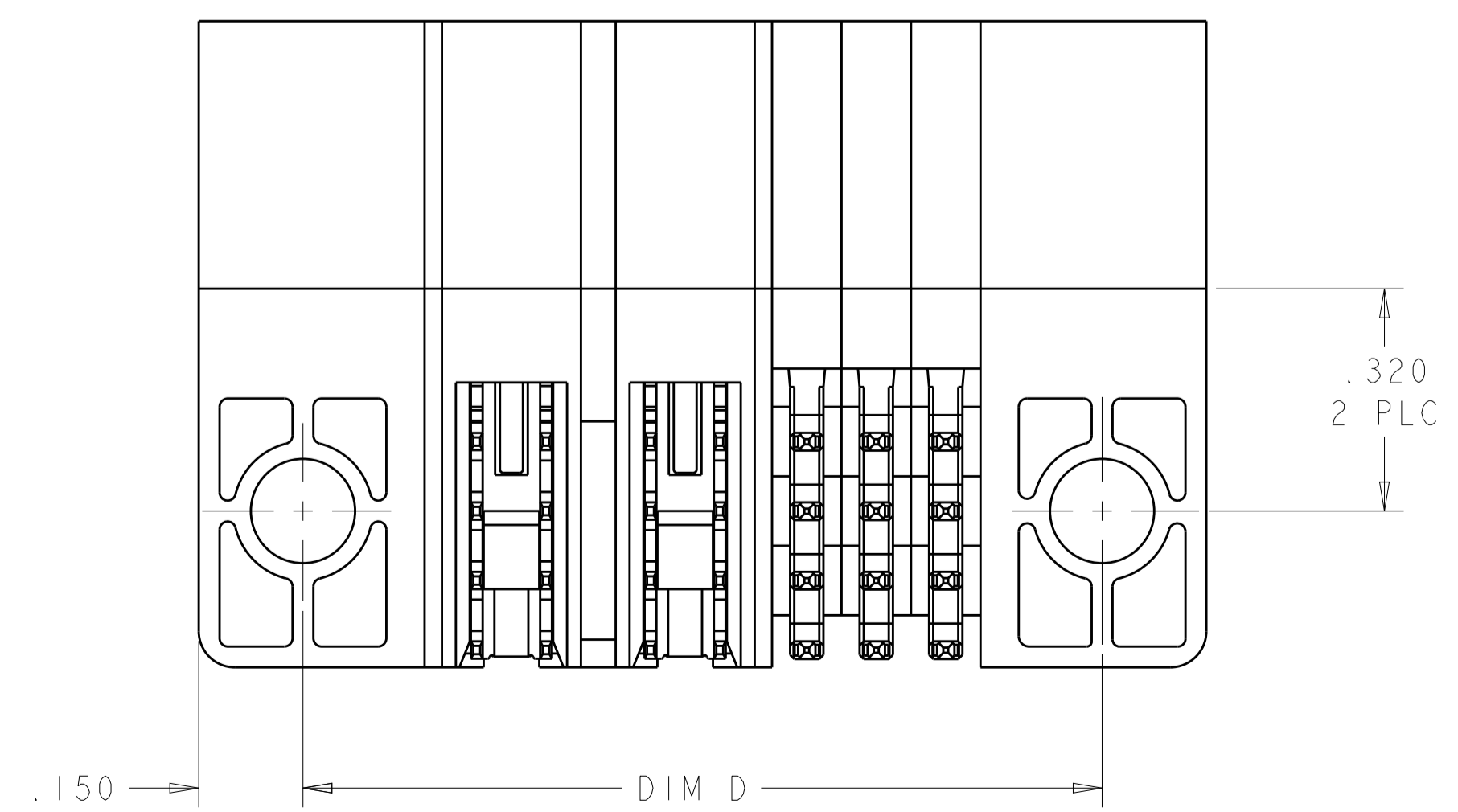
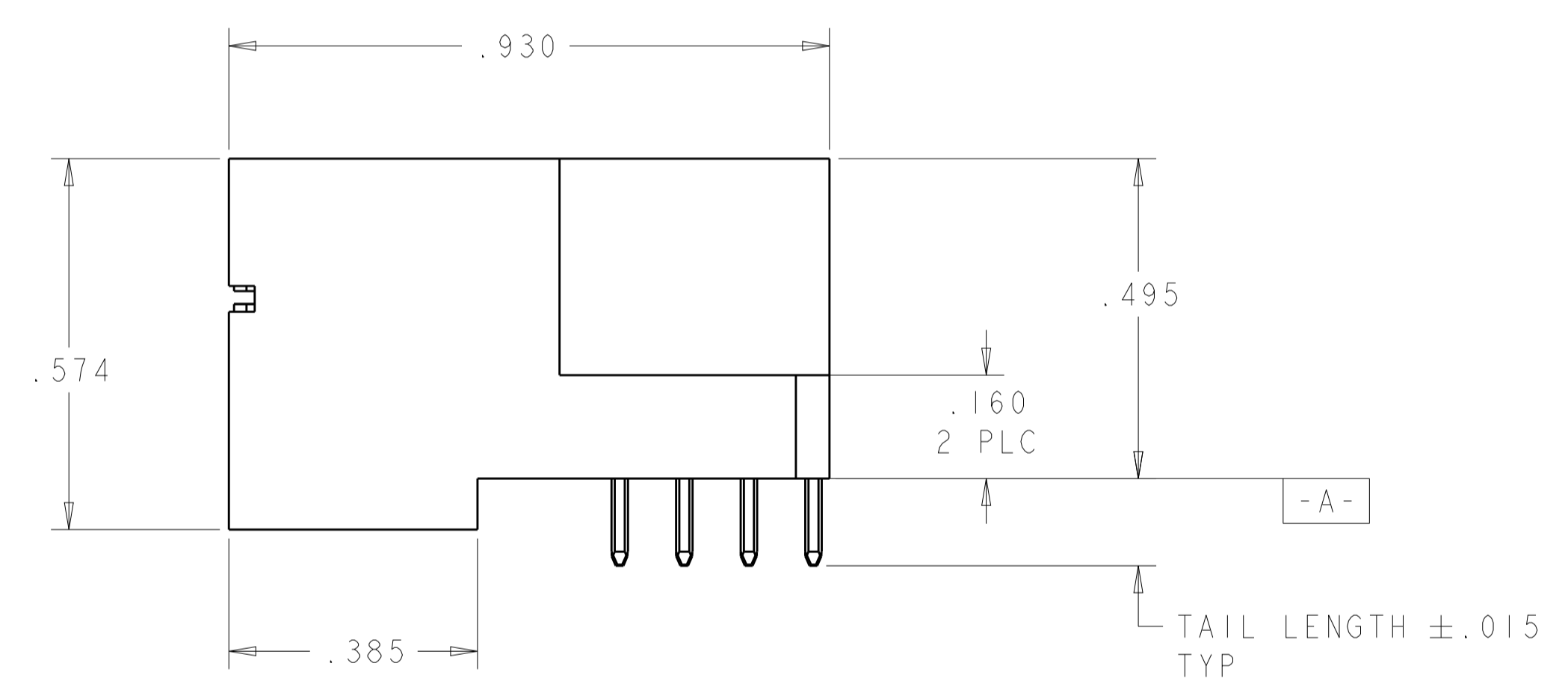
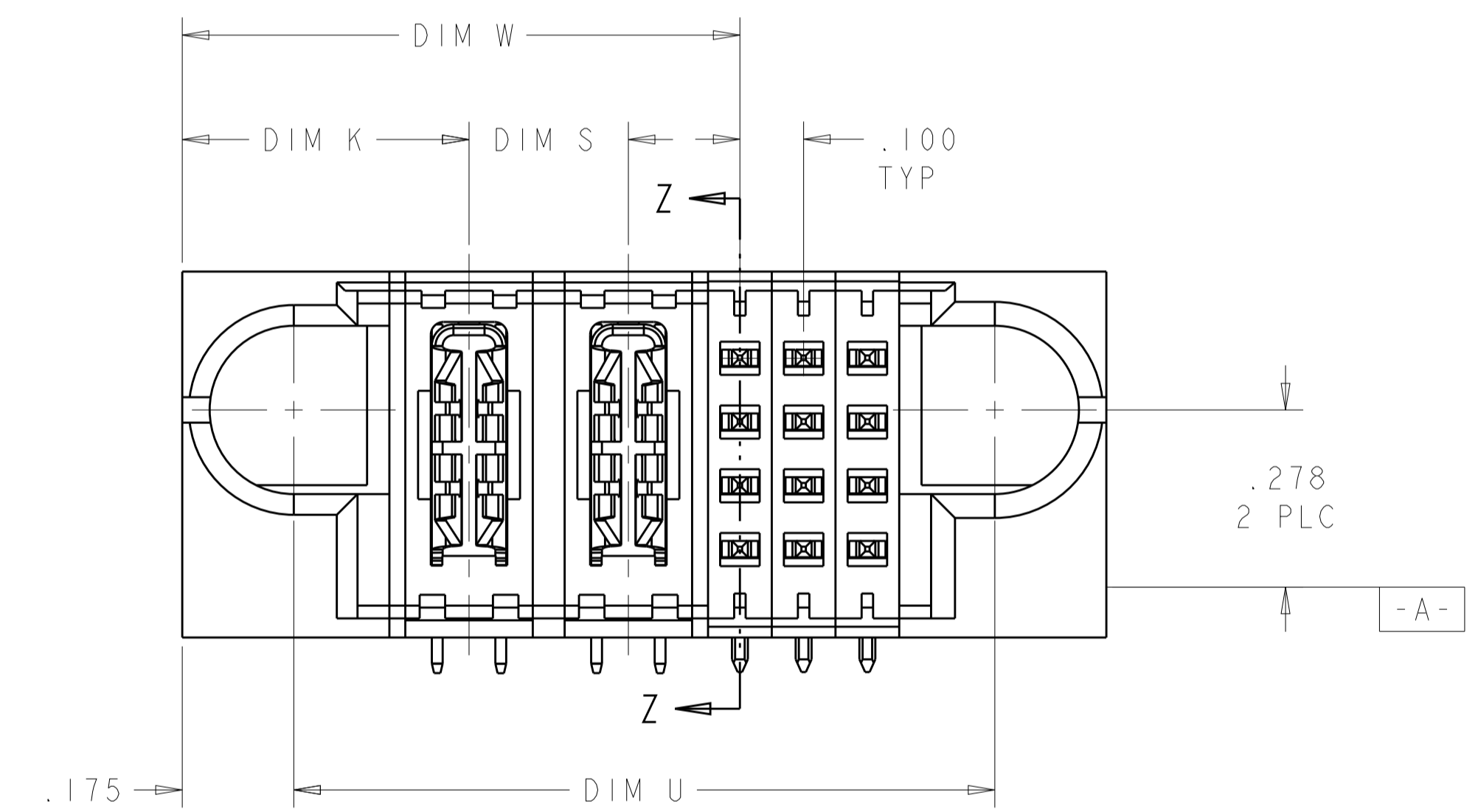

.250	2.250	1.900	1.950	1.375	.450	4P + 24S	6450322-8
.200	4.775	4.425	4.475	2.200	.450	9P + 92S	6450322-7
.300	1.950	1.600	1.650	1.275	.475	3ACP + 16S	6450322-6
.250	1.450	1.100	1.150	.875	.450	2P + 12S	6450322-3
DIM S	DIM L	DIM U	DIM D	DIM W	DIM K	DESCRIPTION	PART NUMBER

<small>THIS DRAWING IS UNPUBLISHED. RELEASED FOR PUBLICATION BY TYCO ELECTRONICS CORPORATION. ALL RIGHTS RESERVED.</small>		DWN: R. GRZYBOWSKI CHK: M. PERCHERKE APVD: M. PERCHERKE	16 JUN 05 16 JUN 05	Tyco Electronics Corporation Harrisburg, PA 17105-3608
DIMENSIONS: INCHES		TOLERANCES UNLESS OTHERWISE SPECIFIED:		NAME: RIGHT ANGLE HEADER ASSEMBLY W/GUIDES MULTI-BEAM XL
0 PLC ±. 1 PLC ±.01 2 PLC ±.01 3 PLC ±.005 4 PLC ±.0020 ANGLES ±.7°		PRODUCT SPEC: 108-1973 APPLICATION SPEC: 114-13038		SIZE: A1 CAGE CODE: 00779 DRAWING NO: 6450322
MATERIAL: 2		FINISH: 3		WEIGHT: - CUSTOMER DRAWING: - SCALE: 4:1 SHEET: 1 OF 4 REV: B6

LOC		DIST		REVISIONS			
P	LYN	DATE	DMN	APVD	DESCRIPTION		
-	-	-	-	-	SEE SHEET 1		

PART NUMBER	ROWS	POWER		SIGNAL		
		P1	P2	1	2	3
6450322-3	D	PM	PM	J	J	J
	C			K	K	K
	B			N	N	N
	A			S	S	S
2P + 12S						

PART NUMBER	ROWS	POWER			SIGNAL			
		P1	P2	P3	1	2	3	4
6450322-6	D	PM	PM	PM	J	J	J	J
	C				K	K	K	K
	B				N	N	N	N
	A				S	S	S	S
3ACP + 16S								

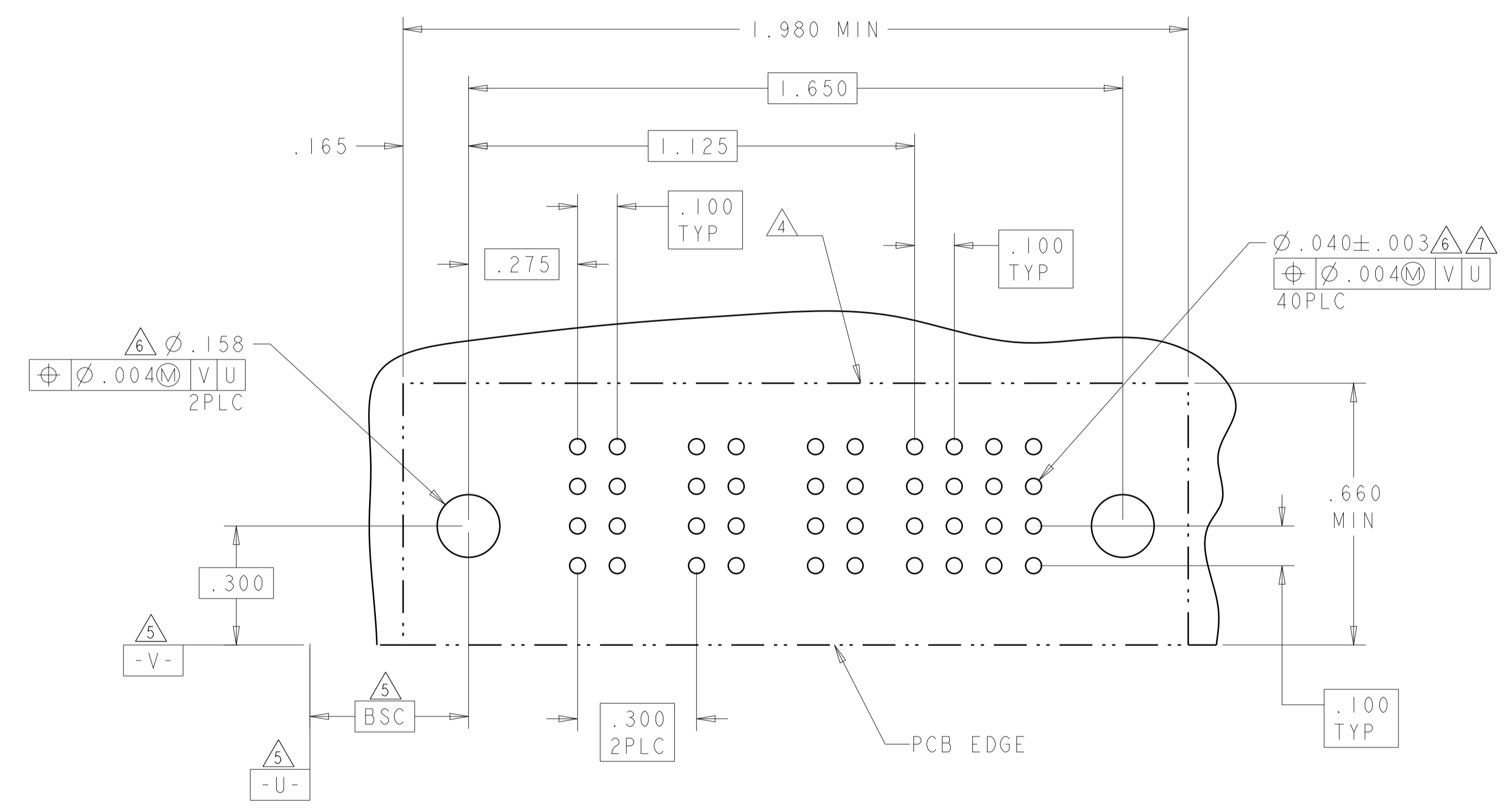
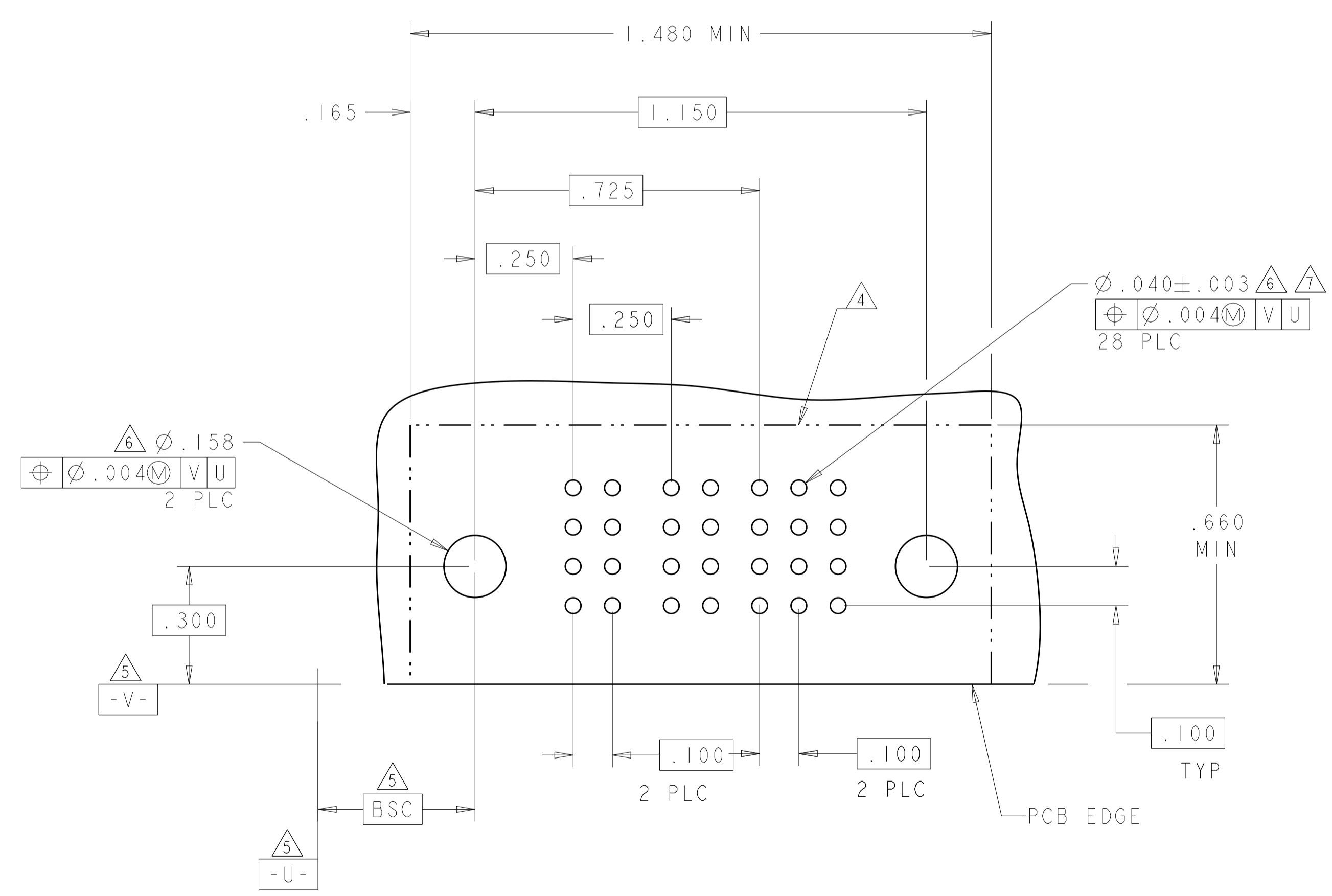

CODE	MATING SEQUENCE	TAIL LENGTH	ROW
J	STD	.135"	D
K	STD	.135"	C
N	STD	.135"	B
S	STD	.135"	A

PM	.135"	DIMENSIONS: INCHES	TOLERANCES UNLESS OTHERWISE SPECIFIED: 0 PLC ±.01 1 PLC ±.01 2 PLC ±.01 3 PLC ±.005 4 PLC ±.0020 ANGLES ±.2°	DWN R. GRZYBOWSKI CHK M. PERCHERKE APVD M. PERCHERKE	16 JUN 05 16 JUN 05	Tyco Electronics Tyco Electronics Corporation Harrisburg, PA 17105-3608
CODE	TAIL LENGTH					
POWER CONTACT		MATERIAL	FINISH	PRODUCT SPEC 108-1973	APPLICATION SPEC 114-13038	RESTRICTED TO
				WEIGHT	114-13038	REV B6
				CUSTOMER DRAWING	SCALE 4:1	SHEET 2 OF 4

LOC	DIST	REVISIONS			
P	LTN	DESCRIPTION	DATE	OWN	APVD
GP	00	SEE SHEET 1			

PART NUMBER	ROWS	POWER								SIGNAL																					
		P1	P2	P3	P4	P5	P6	P7	P8	P9	1	2	3	4	5	6	7	8	9	10	11	12	13	14	15	16	17	18	19	20	21
6450322-7	D									J	J	J	J	J	J	J	J	J	J	J	J	J	J	J	J	J	J	J	J	J	J
	C	PM		PM		PM		PM		K	K	K	K	K	K	K	K	K	K	K	K	K	K	K	K	K	K	K	K		
	B									N	N	N	N	N	N	N	N	N	N	N	N	N	N	N	N	N	N	N	N	N	N
A		S	S	S	S	S	S	S	S	S	S	S	S	S	S	S	S	S	S	S	S	S	S	S	S	S	S	S	S	S	

NO CONTACTS LOADED

NO CONTACTS LOADED

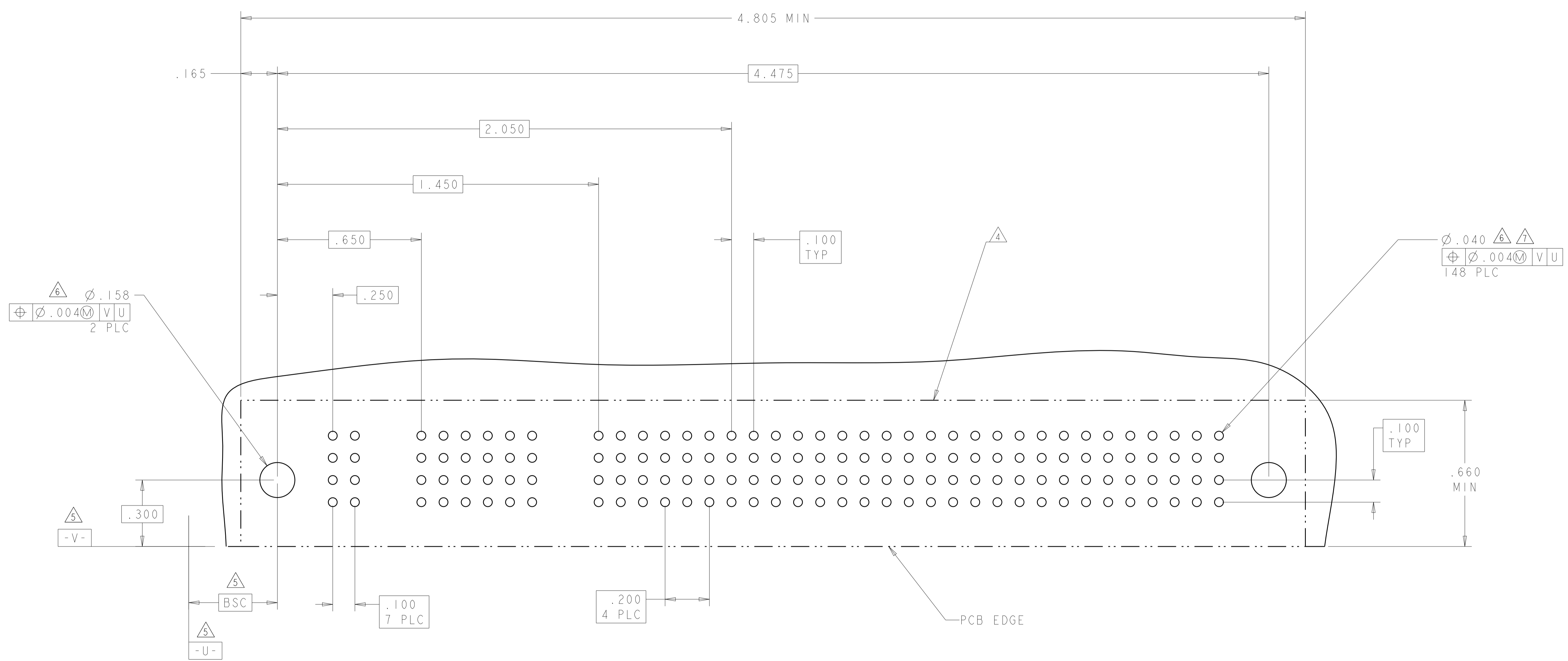

DIMENSIONS: INCHES		TOLERANCES UNLESS OTHERWISE SPECIFIED: 0 PLC ±. 1 PLC ±.01 2 PLC ±.01 3 PLC ±.005 4 PLC ±.0020 ANGLES ±.7° FINISH		DWN: R. GRZYBOWSKI 16 JUN 05 CHK: M. PERCHERKE 16 JUN 05 APVD: M. PERCHERKE		Tyco Electronics Corporation Harrisburg, PA 17105-3608	
MATERIAL: -		FINISH: -		NAME: RIGHT ANGLE HEADER ASSEMBLY W/GUIDES MULTI-BEAM XL		SIZE: A1 CAGE CODE: 00779 DRAWING NO: 6450322	
CUSTOMER DRAWING		SCALE: 4:1		SHEET: 3 OF 4		REV: B6	

LOC	DIST	REVISIONS			
P	LTN	DESCRIPTION	DATE	DWN	APVD
-	-	SEE SHEET 1	-	-	-

PART NUMBER	ROWS	POWER				SIGNAL					
		P1	P2	P3	P4	1	2	3	4	5	6
6450322-8	D	PM	PM	PM	PM	J	J	J	J	J	J
	C					K	K	K	K	K	K
	B					N	N	N	N	N	N
	A					S	S	S	S	S	S
4P + 24S											

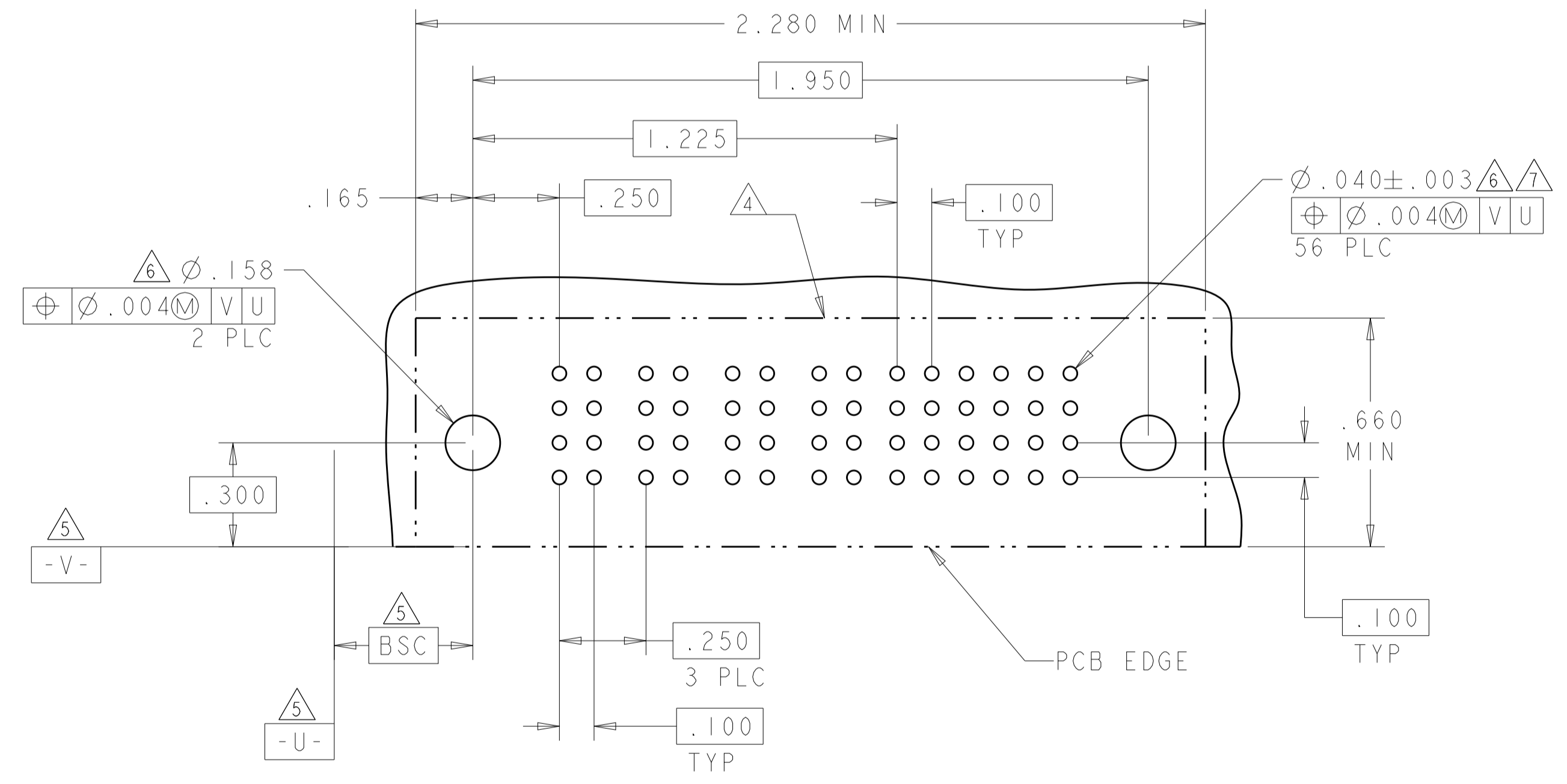

<small>THIS DRAWING IS UNPUBLISHED. RELEASED FOR PUBLICATION BY TYCO ELECTRONICS CORPORATION. ALL RIGHTS RESERVED.</small>		DWN: R. GRZYBOWSKI 16 JUN 05 CHK: M. PERCHERKE 16 JUN 05 APVD: M. PERCHERKE	Tyco Electronics Corporation Harrisburg, PA 17105-3608
DIMENSIONS: INCHES 		TOLERANCES UNLESS OTHERWISE SPECIFIED: 0 PLC ±. 1 PLC ±.01 2 PLC ±.01 3 PLC ±.005 4 PLC ±.0020 ANGLES ±.2° FINISH: -	NAME: RIGHT ANGLE HEADER ASSEMBLY W/GUIDES MULTI-BEAM XL PRODUCT SPEC: 108-1973 APPLICATION SPEC: 114-13038 WEIGHT: - CUSTOMER DRAWING
MATERIAL: - FINISH: -		SIZE: A1 CAGE CODE: 00779 DRAWING NO: 6450322	RESTRICTED TO: - SCALE: 4:1 SHEET: 4 OF 4 REV: B6