

DWG. NO. SDA 70247-**-00-04
CAD FILE S7024700.DGN

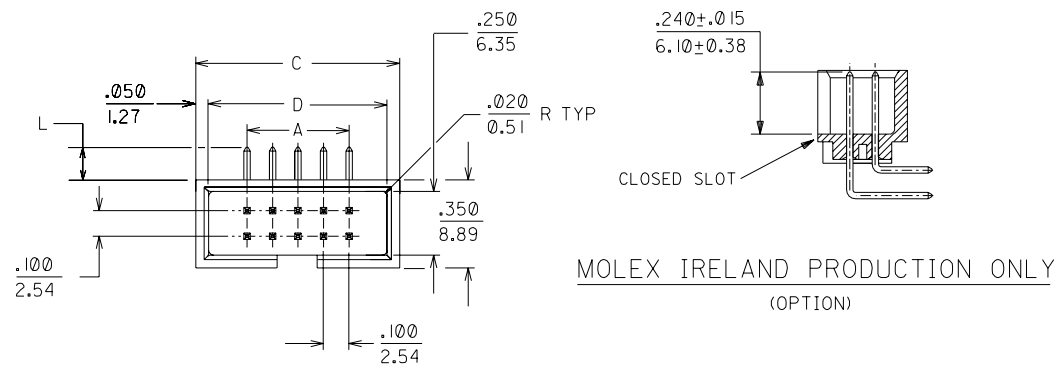

MOLEX IRELAND PRODUCTION ONLY
(OPTION)

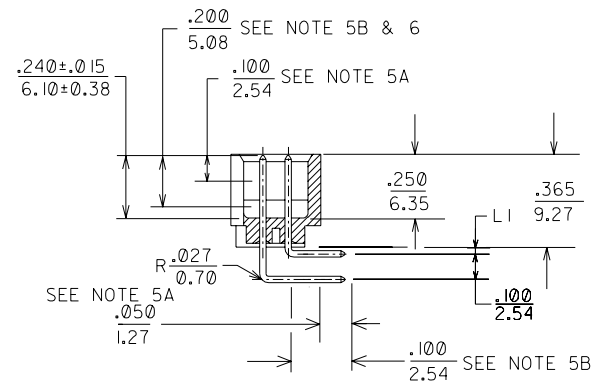
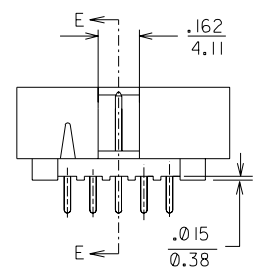

SECTION E-E

△ PART NO	L	LI
70247-**-34		
70247-**-00		
70247-**-01	.120	0
70247-**-02	3.05	
70247-**-03		
70247-**-04		

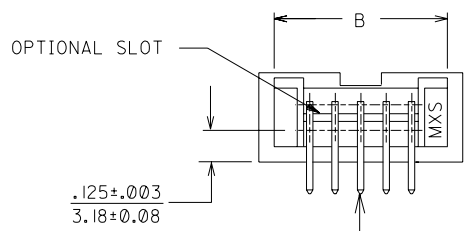

AT TIP BOTH ENDS

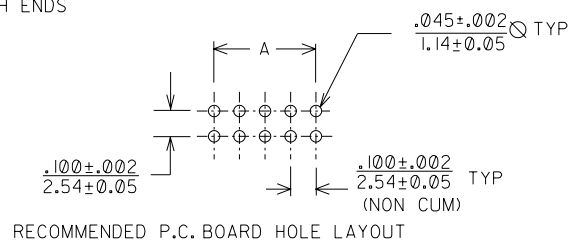

△

PART NO.	CKT SIZE	A	B	C	D
70247-08**	08	0.300/7.62	0.580/14.73	0.700/17.78	0.600/15.24
70247-10**	10	0.400/10.16	0.680/17.27	0.800/20.32	0.700/17.78
70247-12**	12	0.500/12.70	0.780/19.81	0.900/22.86	0.800/20.32
70247-14**	14	0.600/15.24	0.880/22.35	1.000/25.40	0.900/22.86
70247-16**	16	0.700/17.78	0.980/24.89	1.100/27.94	1.000/25.40
70247-20**	20	0.900/22.86	1.180/29.97	1.300/33.02	1.200/30.48
70247-24**	24	1.100/27.94	1.380/35.05	1.500/38.10	1.400/35.56
70247-26**	26	1.200/30.48	1.480/37.59	1.600/40.64	1.500/38.10
70247-30**	30	1.400/35.56	1.680/42.67	1.800/45.72	1.700/43.18
70247-34**	34	1.600/40.64	1.880/47.75	2.000/50.80	1.900/48.26
70247-40**	40	1.900/48.26	2.180/55.37	2.300/58.42	2.200/55.88
70247-44**	44	2.100/53.34	2.380/60.45	2.500/63.50	2.400/60.96
70247-48**	48	2.300/58.42	2.580/65.53	2.700/68.58	2.600/66.04
70247-50**	50	2.400/60.96	2.680/68.07	2.800/71.12	2.700/68.58
70247-56**	56	2.700/68.58	2.980/75.69	3.100/78.74	3.000/76.20
70247-60**	60	2.900/73.66	3.180/80.77	3.300/83.82	3.200/81.28
70247-64**	64	3.100/78.74	3.380/85.85	3.500/88.90	3.400/86.36
70247-72**	72	3.500/88.90	3.780/96.01	3.900/99.06	3.800/96.52

NOTES:

- PIN PUSHOUT FORCE (.9072KG)/2LBS MIN.
- PIN SOLDERABILITY PER MOLEX SPEC. ES-152
- PRODUCT SPEC: PS-70246 APPLIES.
- WAFER TO BE FLAT WITHIN (0.03MM/CM) 0.0031IN/IN
- DIMENSIONS FOR PLATING LOCATION : A-MEASURE POINT FOR THICKNESS. B-MINIMUM COVERAGE
- GOLD END OF PIN UNLESS OVERALL PLATED.
- △ FINISH : ALL WITH 50uin MIN NICKEL UNDERPLATE OVERALL.
 - **00 - 20uin MIN AU & 100uin MIN TIN IN SELECTED AREAS.
 - **01 - 15uin MIN AU & 75uin MIN TIN IN SELECTED AREAS.
 - **02 - 30uin MIN AU & 75uin MIN TIN IN SELECTED AREAS.
 - **03 - 200uin MIN TIN
 - **04 - 5uin MIN AU & 75uin MIN TIN IN SELECTED AREAS.
 - **34 - 5uin MIN AU OVER 40uin MIN PD/Ni (80/20) & 100uin TIN IN SELECTED AREAS.
- △ CHECK WITH SALES OFFICE FOR AVAILABILITY.

INCH
MM

DO NOT SCALE DRAWING

F	LEAD-FREE CONVERSION AS PER ECN NO. S2004-0489	-	RAVESH-PTL/IM	040319	MATERIAL : PINS: .025 S0.260 BRASS WAFER: 15% G.F.PBT	MOLEX SINGAPORE PTE LTD SHEET 1 OF 1	GENERAL TOLERANCES ± 0.20/.008 REV F
E2	ADD IN SHANNON CLOSED SLOT VERSION (ECN# S2004-0491)	-	SEE LING	040224			
E1	CHG PART NO FORMAT TO 70247-**-** (ECN# S2000-0383)	-	SEE TOH	000412			
E	REVISED PER (ECN# S30055)	-	JACK ANG	920811	FINISH : SEE NOTE 7	DWG. NO.: SDA 70247-**-00-04	TITLE : R.A.SSYY,C-GRID SHROUDED HEADER (SLOTTED W/O STANDOFFS)
D	RTM 48 CKT (ECN# S2124)	-	ANG ROY	910909			
C	CHG PINS PER (ECN# S1630)	-	ANG ROY	910513			
LTR	REVISION RECORD	ECN	DR CHK	DATE	DRAWN BY JENNIFER 210987 APPR'D BY ALAN B 210987	CHK'D BY MAX LAI 901214 SCALE 2:1	
REVISE ONLY ON CAD SYSTEM							