

5040520098  
AWG #24-28

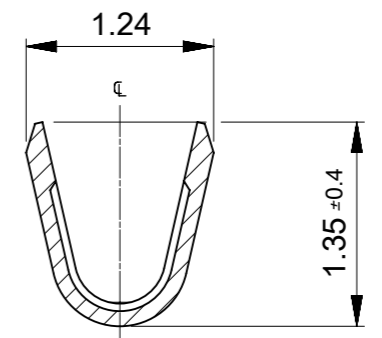

SECTION A-A

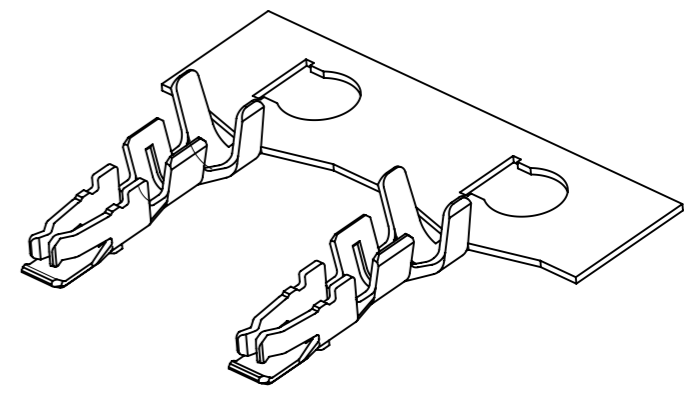
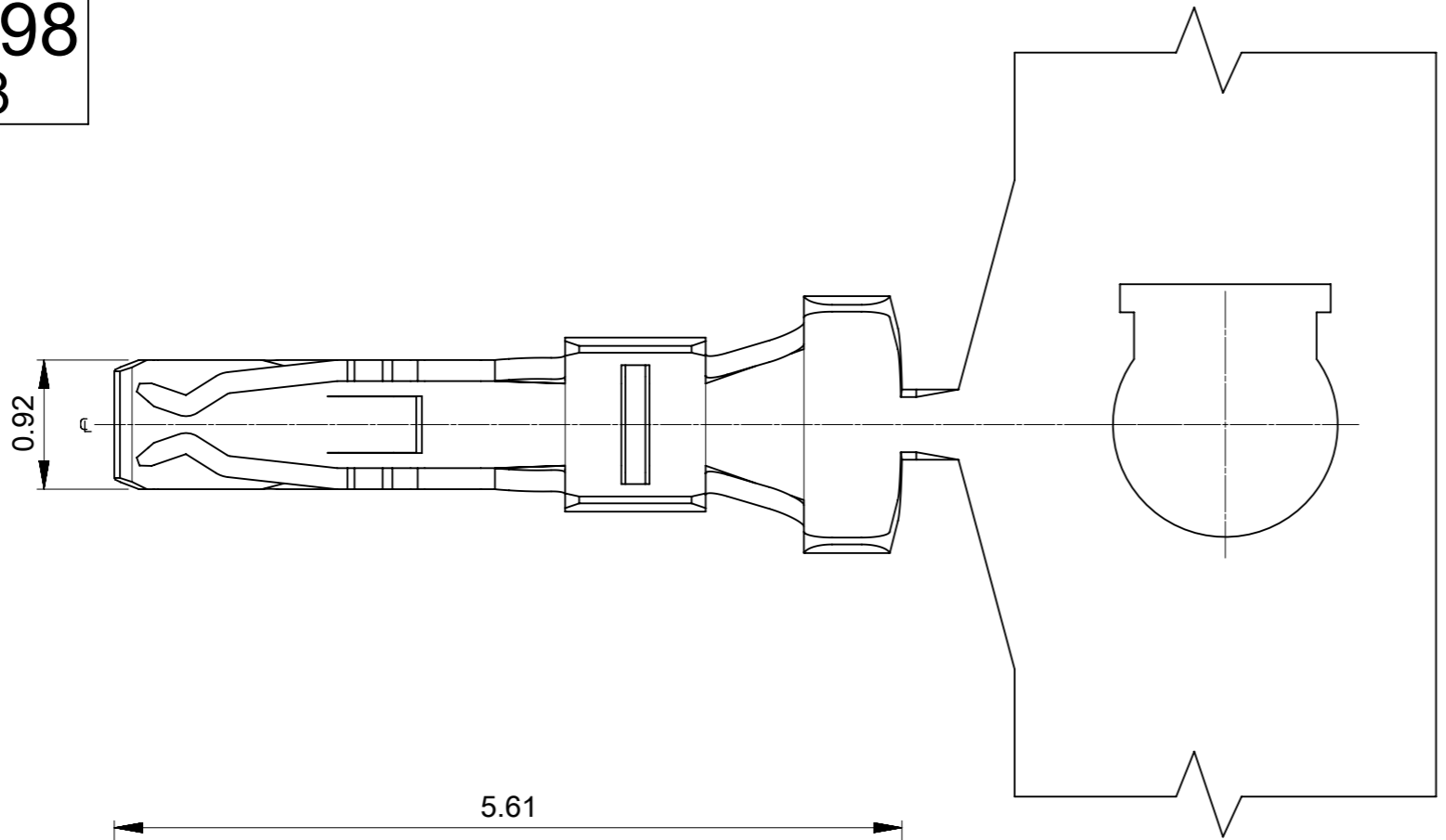
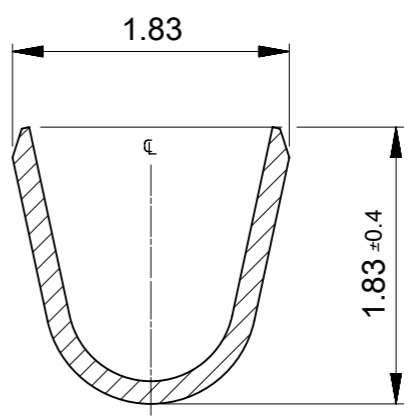

SECTION B-B

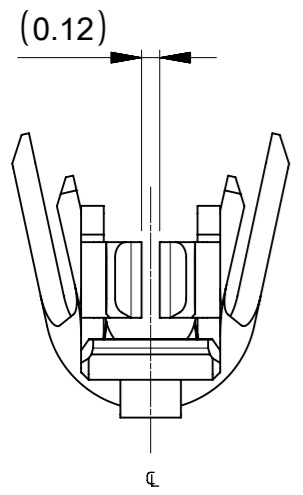
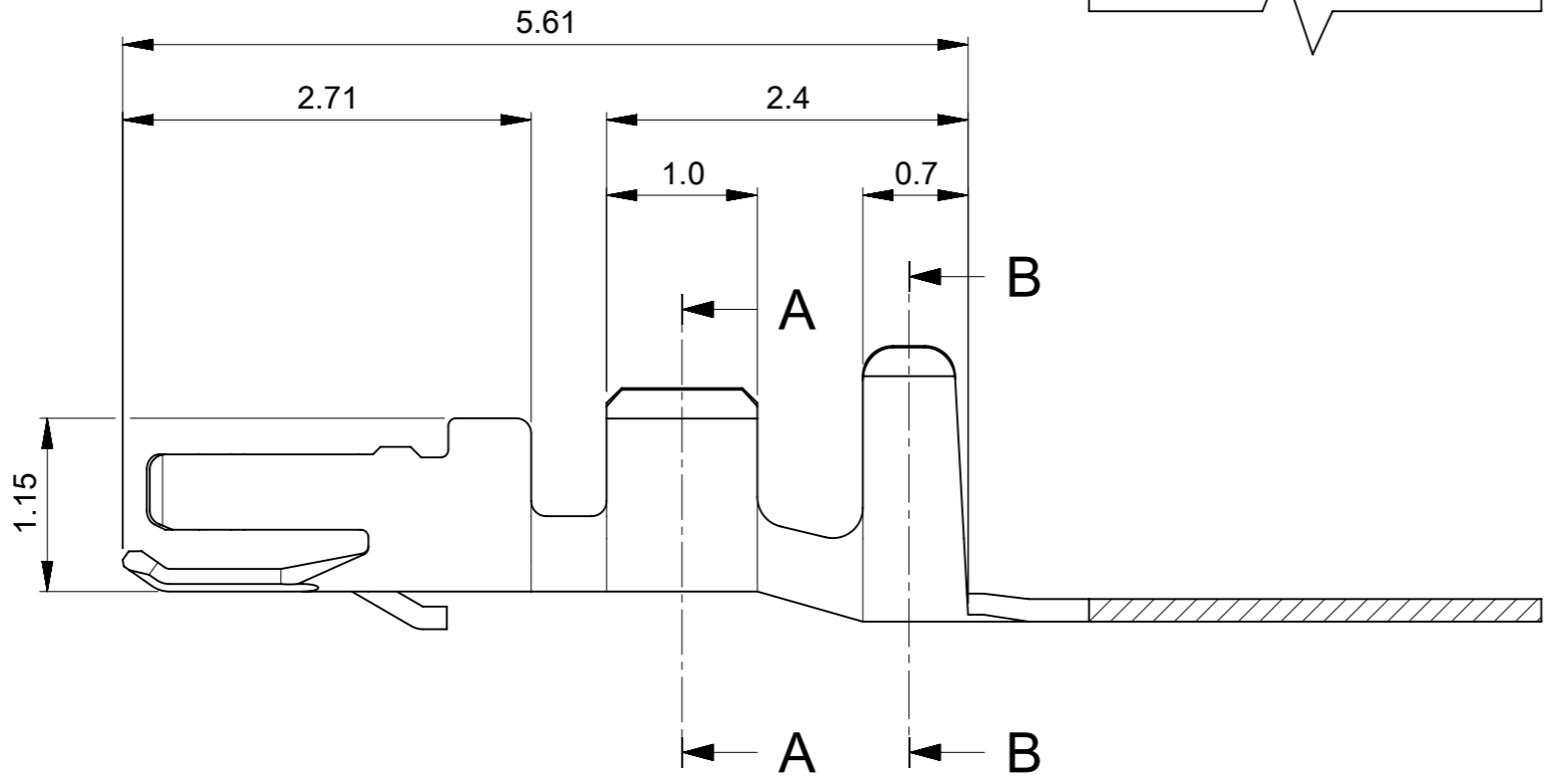

Φ0.8-1.15 mm	AWG #24-28	5040520098	CHAIN
Φ0.54-0.8 mm	AWG #30-32	5040520298	
INS. RANGE	WIRE RANGE	ORDER NO.	FORM
梱包状態 : リール PACKAGING : REEL			

THIS DRAWING CONTAINS INFORMATION THAT IS PROPRIETARY TO MOLEX ELECTRONIC TECHNOLOGIES, LLC AND SHOULD NOT BE USED WITHOUT WRITTEN PERMISSION									
DIMENSION UNITS	SCALE	CURRENT REV DESC: REDRAWN AND REVISED							
mm	NTS	<b>molex</b>							
GENERAL TOLERANCES (UNLESS SPECIFIED)									
ANGULAR TOL	± 3.0 °	PICO-LOCK1.5 REC CRIMP TERM AWG#24-32							
4 PLACES	± 0.2								
3 PLACES	± 0.2	PRODUCT CUSTOMER DRAWING							
2 PLACES	± 0.2								
1 PLACE	± 0.2	DOCUMENT NUMBER: 5040520000-SD DOC TYPE: PSD DOC PART: 000 REVISION: A							
0 PLACES	± 0.2								
DRAFT WHERE APPLICABLE MUST REMAIN WITHIN DIMENSIONS		THIRD ANGLE PROJECTION	DRAWING	SERIES	MATERIAL NUMBER	CUSTOMER	SHEET NUMBER		
			A3-SIZE	504052	SEE CHART		1 OF 2		

5040520298  
AWG #30-32

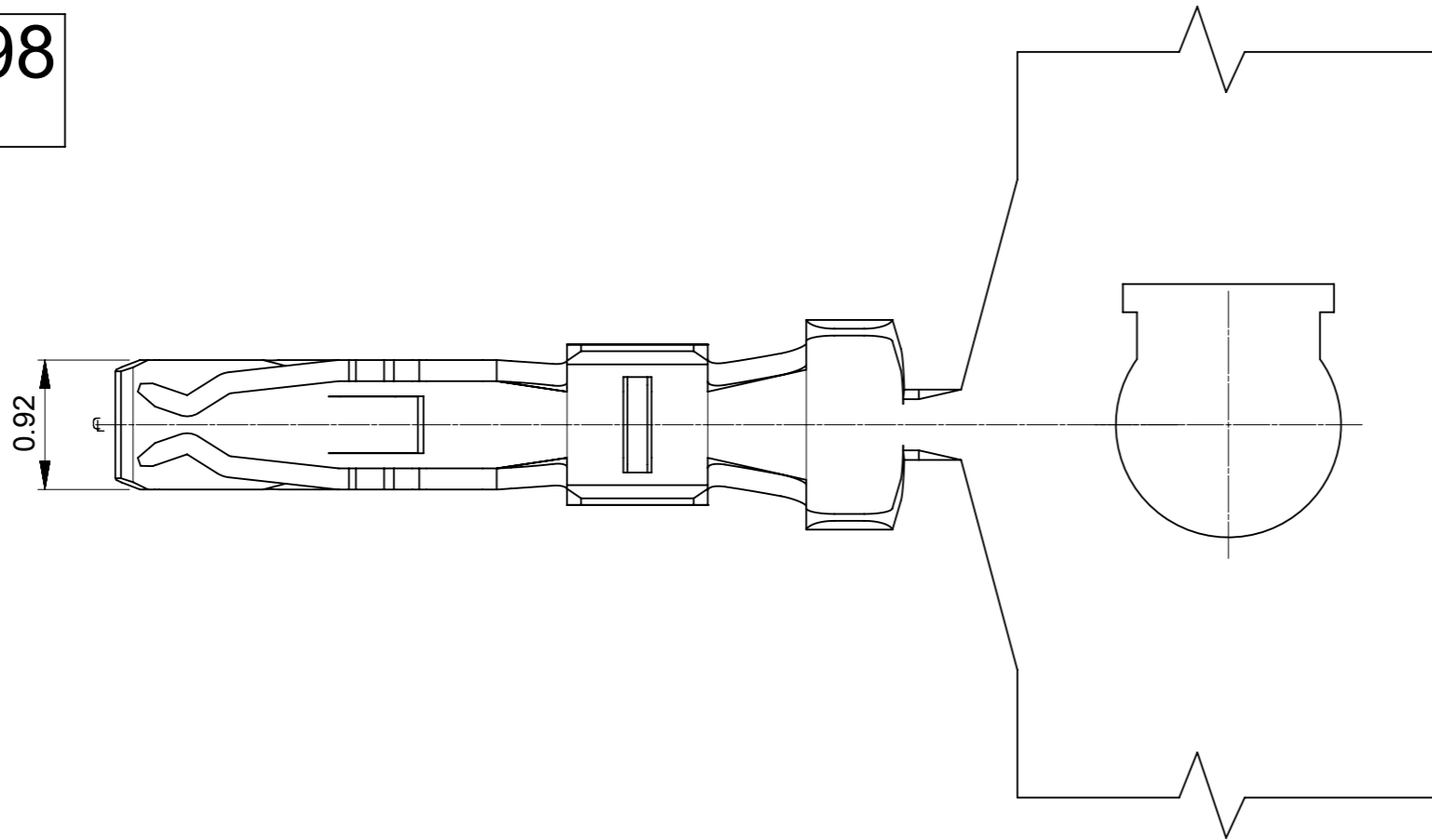

- NOTES .
1. 適合ハウジング : 5 0 4 0 5 1 \* \* \* \*  
APPLICABLE HOUSING : 504051\*\*\*\*
  2. 材質 : 銅合金  
MATERIAL : COPPER ALLOY
  3. めっき仕様 : 金めっき 0.1micro-meter MIN.,  
ニッケル下地 1.0micro-meter MIN.  
PLATING : GOLD PLATING 0.1micro-meter MIN.  
NICKEL UNDER PLATING 1.0micro-meter MIN.
  4. 製品仕様及び取扱いについては、製品仕様書PS-504051-001  
及びコネクタ取扱説明書AS-504051-001を参照願います。  
PLEASE REFER TO PRODUCT SPECIFICATION  
PS-504051-001 AND APPLICATION  
SPECIFICATION AS-504051-001.
  5. 梱包仕様書 : SPK-504052-001.  
PACKING INFORMATION SPK-504052-001.

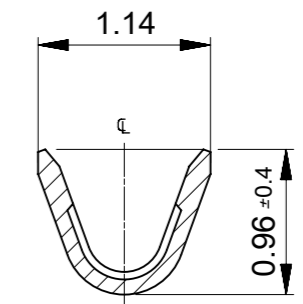

SECTION C-C

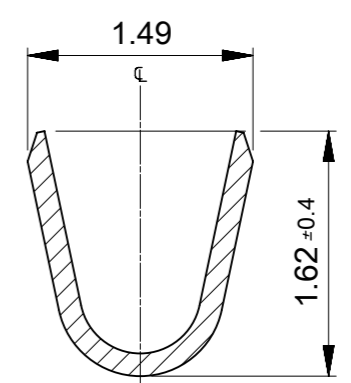

SECTION D-D

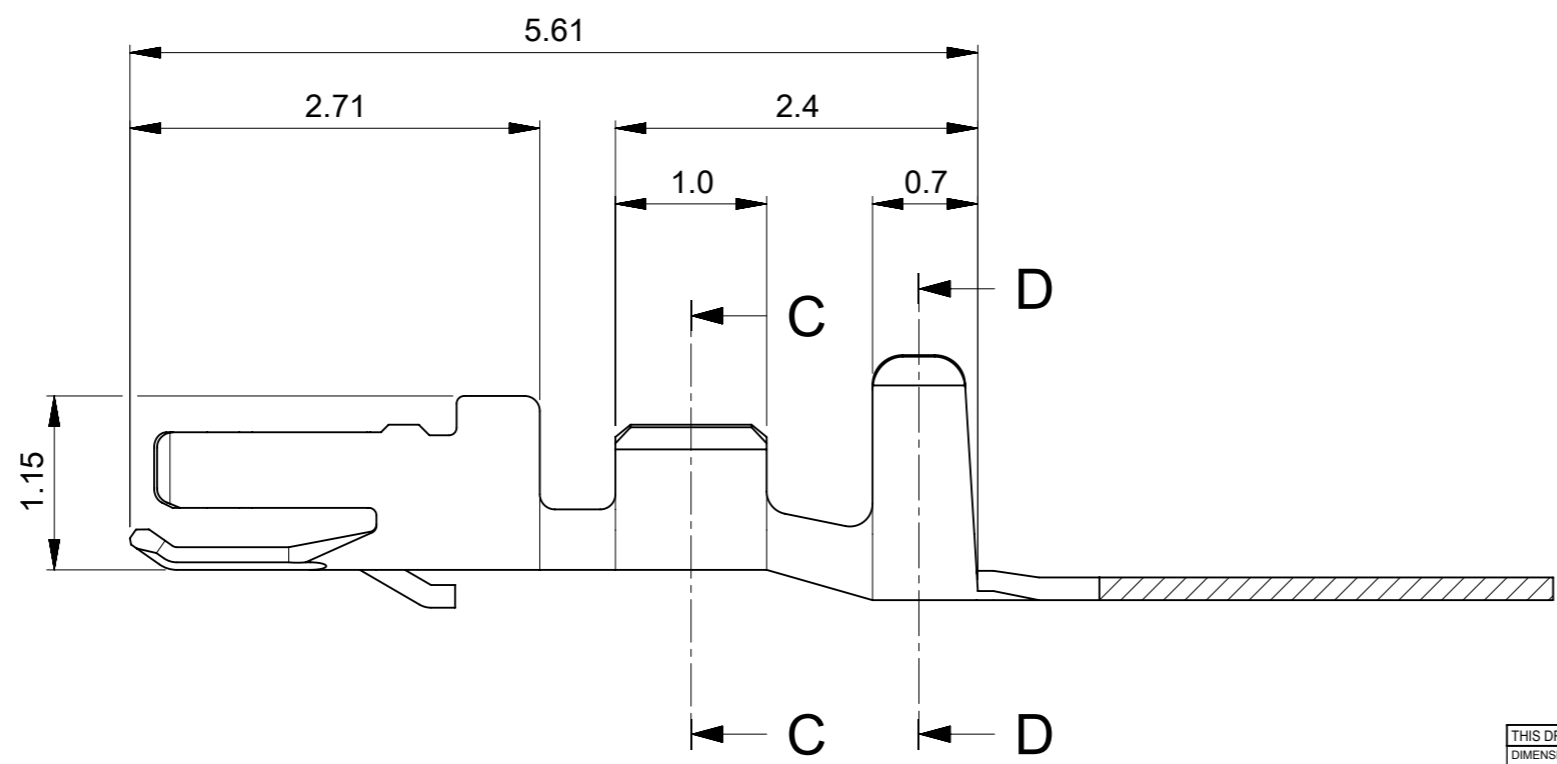
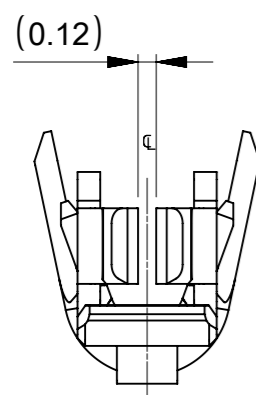

THIS DRAWING CONTAINS INFORMATION THAT IS PROPRIETARY TO MOLEX ELECTRONIC TECHNOLOGIES, LLC AND SHOULD NOT BE USED WITHOUT WRITTEN PERMISSION									
DIMENSION UNITS		SCALE		CURRENT REV DESC: REDRAWN AND REVISED				<b>molex</b>	
mm		NTS							
GENERAL TOLERANCES (UNLESS SPECIFIED)									
ANGULAR TOL		± 3.0 °		EC NO: 612189		2018/03/14		PICO-LOCK1.5 REC CRIMP TERM AWG#24-32	
4 PLACES		± 0.2		DRWN: QHE31		2019/02/18		PRODUCT CUSTOMER DRAWING	
3 PLACES		± 0.2		CHK'D: SAKIYAMA		2019/02/18		DOCUMENT NUMBER	
2 PLACES		± 0.2		APPR: KOMURAKAMI		2019/02/18		5040520000-SD	
1 PLACE		± 0.2		INITIAL REVISION:		2018/03/14		DOC TYPE	
0 PLACES		± 0.2		DRWN: QHE31		2019/02/18		PSD	
DRAFT WHERE APPLICABLE MUST REMAIN WITHIN DIMENSIONS		THIRD ANGLE PROJECTION		DRAWING		SERIES		MATERIAL NUMBER	
		A3-SIZE		504052		SEE CHART		CUSTOMER	
								REVISION	
								000 A	
								SHEET NUMBER	
								2 OF 2	